

RM-2350W-HD

Triple 5" HD/SD-SDI/Analog Video Monitors



Full feature set, cost effective, reliable triple 5" video monitor with in-screen audio level meters, vectorscope and waveform

The RM Series is a full-featured, low-cost range of in-rack HD/SD-SDI and CVBS video monitors ideal for the many feeds in mobile trucks, news and transmission control rooms, duplication, and post production applications.

Tilting monitors come standard with in-monitor level metering, selectable video waveform and vectorscope, safe area and title markers, labeling, tally, timecode, video format, and built-in color bars, as well as familiar CRT-style picture controls and an intuitive on-screen configuration menu.

Rear Panel

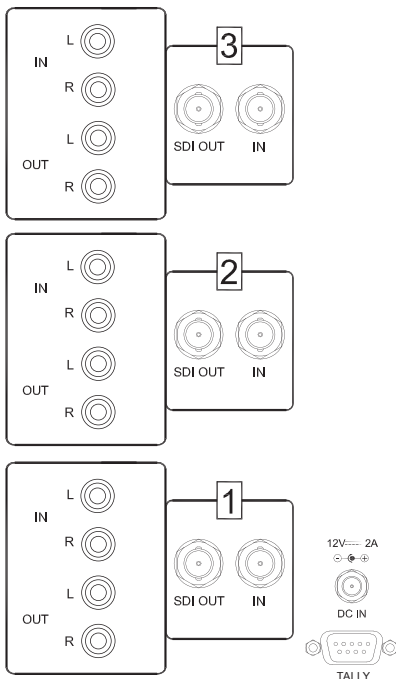

Input signals are automatically detected and up to 8 of the 16 audio channels embedded in an HD/SD-SDI bitstream may be selected for visual monitoring on 8 on-screen bar graph style level meters on the HD and 2HD models. A headphone jack provides audible stereo monitoring of selected left and right channels.

Each of the three high-resolution LCD screens display high-definition or standard-definition video at either 16:9 or 4:3 aspect ratio. Parameters are selected and adjusted using an on-screen display menu.

Benefits:

- On-screen level meters provide confidence audio monitoring
- Tally and on-screen labeling provide quick and easy signal identification
- CRT-style image controls allow video image enhancement for each screen individually
- User defined hot key functionality provides either H/V delay, underscan, on-screen display, and more

Features:

- In-picture level metering, waveform, and vectorscope display
- Labelling, tally, timecode, detected video format, safe and title markers display
- On-screen image calibration controls
- Gamma color calibration
- Built-in color bars
- User-defined function buttons
- Intuitive on-screen menu
- Headphone outputs
- Built in speakers



Order Part Numbers:

RM-2350W-HD: 8001-0350 (One Input/One Output)
RM-2350W-2HD: 8001-0360 (Two Inputs/No Outputs)

RM-2350W-HD

Triple 5" HD/SD-SDI/Analog Video Monitors

Block Diagram

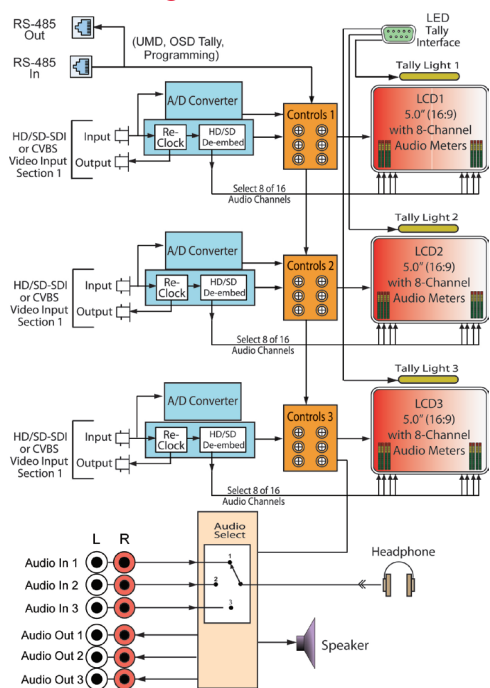

RM Series In-screen Features

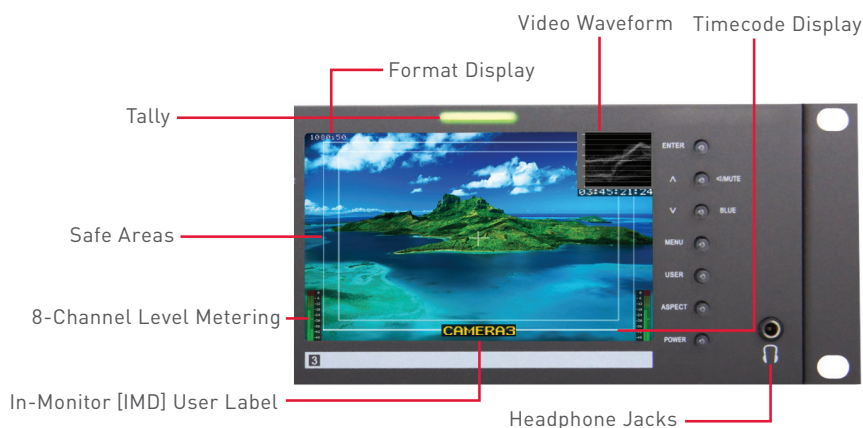

Inputs

- 3 Auto-Sensing HD/SD-SDI, CVBS Inputs on BNC (1 per screen)
- 6 Analog Audio Inputs (2 RCA per LCD screen)
- 1 RS-485 on RJ-45 Input

Outputs

- 3 HD/SD-SDI, CVBS Outputs on BNC (1 per screen)
- 6 Analog Audio Outputs (2 RCA per LCD screen)
- 1 RS-485 on RJ-45 Output

Specifications

[View complete list of specifications online at wohler.com](http://www.wohler.com)

Display Type	Active color matrix amorphous 5", LCD TFT screens
Display Size	5" Diagonal
Resolution	800 x 480
Aspect Ratio	16:9 native 4:3 selectable
Active Viewing Area	4.3" H x 2.6" V (108 mm H x 64.8 mm V)
Viewing Angle	170° H x 170° V
Luminance	300 cd/m ²
Colors	16.7 million
Contrast	600:1
Dot Pitch	0.135 mm H x 0.135 mm Y
Pixel Response	<25 ms off-on-off (black to white to black)
Space Requirements	2RU in a standard 19" rack
Accessories Included	AC power cord
Power Connector	AC power adapter (100-240VAC to 12 VDC)
Power Requirements	Power to the unit connects to mains power (100 to 240 VAC ± 10%, 50/60Hz)
Power Consumption	10W
Dimensions (W x H x D)	19" x 3.5" x 2.7" (482 mm x 88 mm x 69 mm)
Shipping Weight / Net Weight	10 lbs (4.5 kg) / 7 lbs (3.2 kg)

Wohler Technologies, Inc.
Worldwide Headquarters
31055 Huntwood Avenue
Hayward, CA 94544 USA
Phone: +1 510 870 0810
Email: sales@wohler.com

Wohler Technologies/APAC
45/F, The Lee Gardens
33 Hysan Avenue
Causeway Bay, Hong Kong
Phone: +852 8199 0563
Email: sales@wohler.com

Wohler Technologies/EMEA
Suite 3, Medaxon House
Mill Mead, Staines
TW18 4UQ, UK
Phone: +44 (0) 2071 935507
Email: sales@wohler.com

Infinite Possibilities.



One Wohler.