

6-Channel HD/SD-SDI Dolby A/V Monitor

VAMP-AC-3/M



Dual input 4.3" looped HD/SD-SDI video monitor. Also includes a 6-channel Dolby D and PCM audio monitor with metering, drawing from 1 of 2 undecoded Dolby stream inputs

The VAMP AC-3/M is a complete integrated 6 channel Dolby Digital audio and SDI video monitoring system as well as professional level metering in a compact two rack space cabinet. A 4.3" widescreen color active matrix TFT LCD displays all formats of SDI video from two auto-sensing HD/SD-SDI inputs with re-clocked output. The audio source is selectable between embedded SDI and AES Dolby D.

The VAMP AC-3/M features six 53 segment highresolution tri-color LED level meters showing simultaneous VU and PPM for superior level metering. Output limiter circuits are incorporated to protect the speakers, and extensive magnetic shielding allows placement immediately adjacent to video monitors with no color impurities.

The unique design provides optimally focused sound for operators in an ultra near field (1 to 3 ft.) working environment and offers performance comparable to that of many separate monitor pairs, yet does so without the installation hassles, awkward speaker placements and "added-on" look. This provides for a higher SPL for the operator while reducing overall ambient sound and adjacent bay crosstalk. Extended HF response reveals potential problems with audio whine or hiss and electronic rather than acoustic cancellation of bass frequencies provides positive audible detection of out-of-phase (reversed polarity) audio feeds.

Features:

- 4.3" 16:9 format color LCD video screen
- Six high-resolution 53-segment meters showing simultaneous VU and PPM
- Premium quality drivers and power amplifiers
- Output limiter protected speakers

Features:

- Hear and see up to 6 channels of audio simultaneously
- Powerful 100dB SPL at 2 feet (0.6m)
- Focused sound, reduces adjacent bay crosstalk
- Includes an internal Dolby Digital AC-3 decoder
- Balanced analog output of 2 selected channels or multi-channel downmix
- Thorough magnetic shielding

Rear Panel

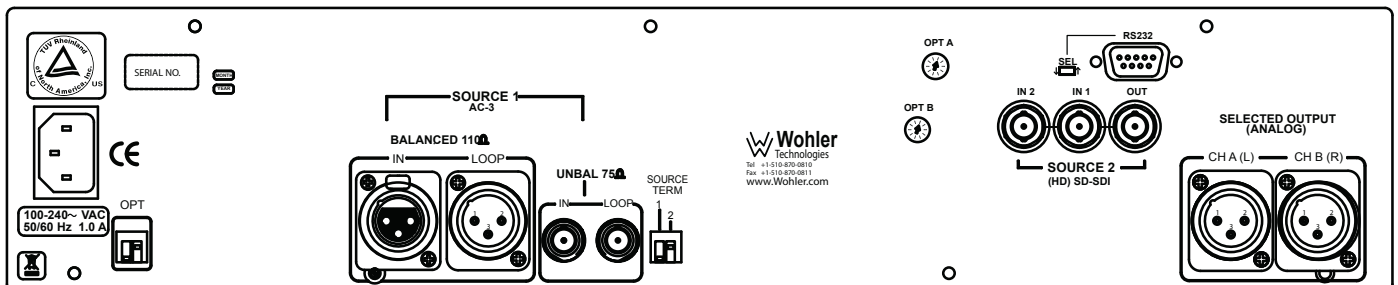

Order Part Number
VAMP AC-3/M: 8003-0070



6-Channel HD/SD-SDI Dolby A/V Monitor

VAMP-AC-3/M

Block Diagram

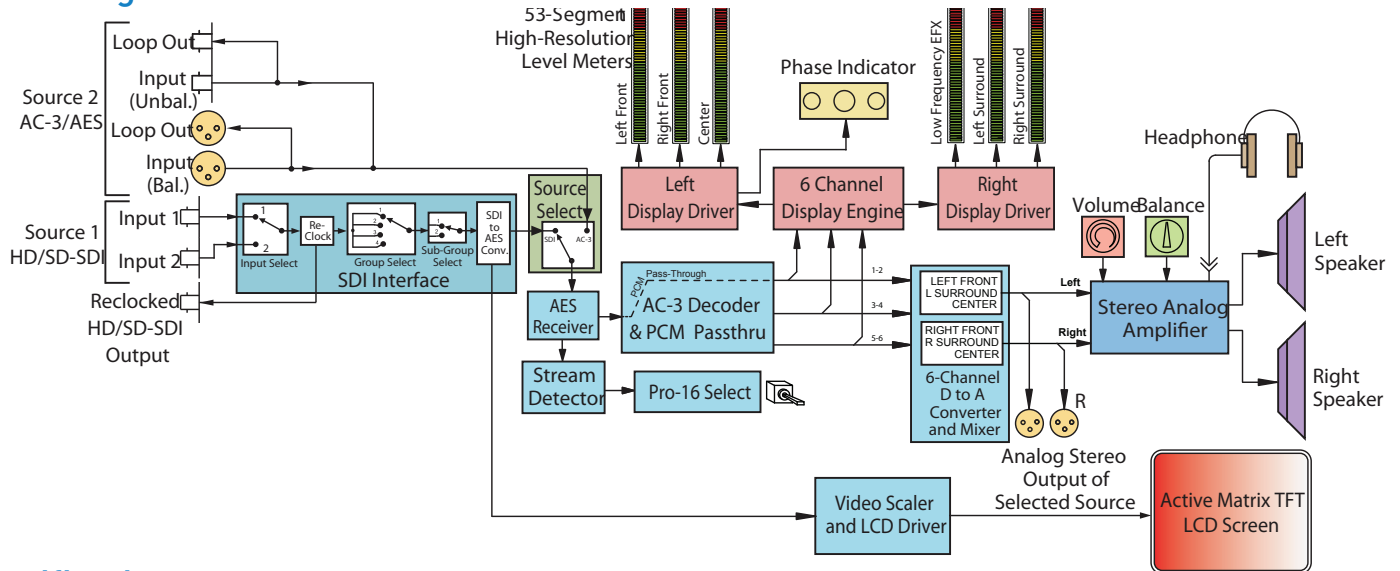

Specifications

Inputs	1 balanced AES (XLR-F) 1 unbalanced AES (BNC) 2 HD/SD-SDI (BNC)
Outputs	1 balanced AES (XLR-M) loop-through 1 unbalanced AES (BNC) loop-through 1 HD/SD-SDI (BNC) 2 selected analog audio (XLR-M) (A and B)
Additional Rear Panel Controls	1 RS-232 2 selection (2-position DIP switch) for AES termination, option 2 options (A and B) (10-position rotary switches)
Dolby	Dolby Digital (also known as AC-3)
Dimensions (H x W x D)	2RU: 4.5" x 19" x 15" (89 mm x 483 mm x 381 mm)
Shipping Weight / Net Weight	20 lbs (9.07 kg)
Supplied Accessories	AC power cord. Alternate power cables are available.
Level Meter Resolution	53 segments
Loudspeaker Power	15 W per speaker
Acoustic Frequency Response	± 5 dB between 60 Hz and 16 kHz (-10 dB at 50 Hz, 20 kHz)
SDI Input Termination	75 Ω Unbalanced
AES Termination	75 Ω Unbalanced • 110 Balanced
Electrical Noise	Better than -75 dB below full output
Electrical THD	<0.15% at any level below limit threshold
Power Requirements	100 V to 240 V AC ± 10%, 50/60 Hz
Power Consumption	60W
Screen Type/Size (diagonal)	4.3" (109.2 mm) Transmissive High-resolution LCD, active matrix TFT
Aspect Ratio	HD-SDI = 16:9, SD-SDI = 4:3 or 16:9
Active Viewing Area	95.04 mm x 53.856 mm
Resolution	480 H x 272 V

View complete list of specifications online at [wohler.com](http://www.wohler.com)

Wohler Technologies, Inc.
Worldwide Headquarters
31055 Huntwood Avenue
Hayward, CA 94544 USA
Phone: +1 510 870 0810
Fax: +1 510 870 0811
Email: sales@wohler.com

Wohler Technologies/APAC
45/F, The Lee Gardens
33 Hysan Avenue
Causeway Bay, Hong Kong
Phone: +852 3180 2240
Fax: +852 3180 2299
Email: salesasia@wohler.com

Wohler Technologies/EMEA
Suite 3
Medaxon House
Mill Mead, Staines TW18 4UQ, UK
Phone: +44 (0) 1784 779815
Email: salesEMEA@wohler.com