

MX624

Six Channel Stereo Mixer with Two Zone Outputs

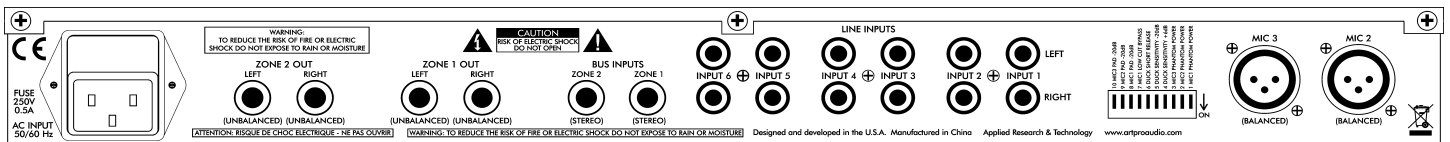

USER'S GUIDE

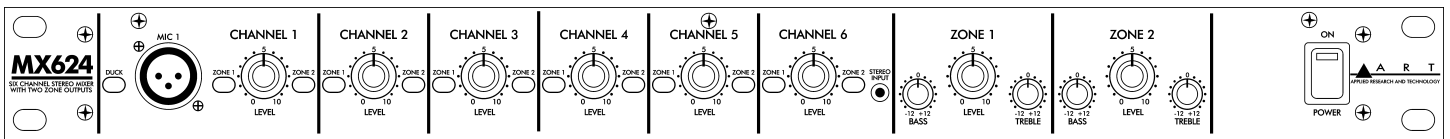

IMPORTANT SAFETY INSTRUCTIONS - READ FIRST



This symbol, wherever it appears, alerts you to the presence of uninsulated dangerous voltages inside the enclosure that may be sufficient to constitute a risk of shock



This symbol, wherever it appears, alerts you to important operating and maintenance instructions in the accompanying literature. Please read the manual.

Read instructions Retain these safety and operating instructions for future reference. Heed all warnings printed here and on the equipment. Follow the operating instructions printed in this user guide.

Do not open There are no user serviceable parts inside. Refer any service work to qualified technical personnel only.

Power sources Only connect the unit to mains power of the type described in this user guide or marked on the rear panel. The power source must provide a good ground connection.

Power cord Use the power cord with sealed mains plug appropriate for your local main supply as provided with the equipment. If the provided plug does not fit into your outlet consult your service agent. Route the power cord so that it is not likely to be walked on, stretched or pinched by items placed upon or against.

Grounding Do not defeat the grounding and polarization means of the power cord plug. Do not remove or tamper with the ground connection on the power cord.

Moisture To reduce the risk of fire or electrical shock, do not expose the unit to rain, moisture or use in damp or wet conditions. Do not place containers of liquid on it, which may spill into any openings

Heat Do not locate the unit in a place close to excessive heat or direct sunlight, as this could be a fire hazard. Locate the unit away from any equipment which produces heat, such as power supplies, power amplifiers and heaters.

Environment Protect from excessive dirt, dust, heat, and vibration when operating and storing. Avoid tobacco ash, drink spillage and smoke, especially that associated with smoke machines.

Handling Protect the controls from damage during transit. Use adequate padding if you need to ship the unit. To avoid injury to yourself or damage to the equipment, take care when lifting, moving or carrying the unit.

Servicing Switch off the equipment and unplug the power cord immediately if it is exposed to moisture, spilled liquid or the power cord or plug becomes damaged during a lightning storm or if smoke odor or noise is noted. Refer servicing to qualified technical personnel only.

Installation Install the unit in accordance with the instructions printed in the user guide.

OVERVIEW

The **ART MX624 Six Channel Stereo Mixer with Two Zone Outputs** is a versatile rack mount mixer that combines six independent stereo input channels and routes them to two stereo zone outputs. The first three input channels can also accept a balanced mono XLR microphone input. +48 Volt phantom power may be independently selected on each of the mic inputs. The first channel's mic input can be used to control, when enabled by a front-panel switch, the ducking of all other channels. All six channels can accept unbalanced stereo line-level signals. Each channel has independent level controls and can be independently routed to either zone output, both or neither. Separate level, bass and treble controls adjust the sound of each zone output. Two bus inputs allow patching of multiple units when more input channels are needed.

The ART MX624 may be used on stage, in the studio, or for permanent install applications including conference rooms, corporate boardrooms, churches, restaurants, small clubs, health clubs and more. A built-in power supply and single high 19-inch rack mount format allows for easy installation and reliable long-term operation.

Features

- Six stereo input channels with individual level controls using RCA phono jacks
- Balanced mono microphone XLRs also available on the first three channels
- Selectable padding on microphone inputs
- Full +48V low-noise phantom power independently switchable for each mic input
- First channel's mic input provides switchable ducking of other channels with selectable parameters
- Front panel 1/8-inch stereo (TRS) mini-phone plug for portable music player input
- Two sets of left and right 1/4-inch mono (TS) main output jacks with master level, bass and treble controls
- Two bus input 1/4-inch mono (TRS) jacks allow units to be chained to provide extra inputs
- Rugged 1U rack-mount steel chassis with built-in power supply
- Perfect for stage, studio and permanent installations
- Three year warranty

CONNECTIONS

Rear Panel Connections

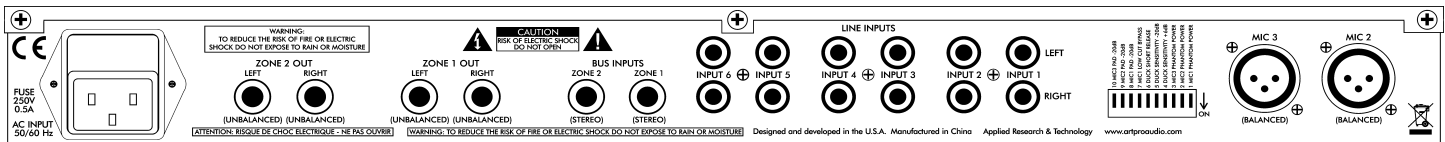

Inputs

MIC 2 and MIC 3

Each of these two female XLR connectors provides a balanced mono input for a microphone, which typically outputs lower signal levels. An additional 26 dB of gain is provided to boost the mic signal to near line level. The mono signal of each mic input is fed to both left and right stereo channels and mixed with the line-level input signals from the RCA jacks of the same channel. This combined signal may be assigned to either Zone 1 or Zone2.

+48V phantom power is available to operate those microphones that contain active electronic circuitry (such as condenser mics) and may be applied by setting the corresponding **PHANTOM POWER** switch in the down (**ON**) position. The switches are located towards the right of the rear panel. See page 8 (**Rear Panel Controls**) for more information. Note: Do not apply phantom power unless the microphone is designed to use it.

LINE INPUT 1 through 6 (LEFT and RIGHT)

Each of these six stereo pairs of RCA phono jacks provide unbalanced inputs for line level signals. The top row of jacks is for left channel connections and the bottom row is for right channel connections.

ZONE 1 and 2 BUS INPUTS

These stereo (TRS) phone jacks provide a direct buffered input connection to the MX624's internal zone buses. They can be used to chain multiple MX624's together, using special cables with dual 1/4-inch mono (TS) phone plugs connected to a single 1/4-inch stereo (TRS) phone plug (tip is left and ring is right). Be sure the connections use shielded cable. Then simply connect the **ZONE 1** or **2 OUT** (or both) jacks of one MX624 to the **ZONE 1** or **2 BUS INPUT** (or both) jacks of another MX624.

Additionally, the **ZONE 1 and 2 BUS INPUTS** may come in handy as extra stereo inputs. Note, however, that these inputs do not have their own level control and the zone assignment is hard-wired.

Outputs

ZONE 1 and 2 OUT (LEFT and RIGHT)

These four 1/4-inch mono (TS) jacks provide a stereo signal from each of the two zones of your MX624 to destination devices, such as amplifiers, powered speakers, or main mixers. These outputs are directly affected by the **ZONE 1 and 2 LEVEL** controls, as well as the associated **BASS** and **TREBLE** controls. Use shielded cables with 1/4-inch mono (TS) plugs to connect to these outputs.

Front Panel Connections

Inputs

MIC 1

This female XLR connector is similar to the two rear panel XLR connectors in all respects, with one important exception. A signal input here can be used to lower the volume of, or "duck", the other five input channels before they are routed to the zone outputs. A typical application would be the lowering of the music volume in a restaurant to announce that someone's table is ready.

The **Operation** section contains information on the front-panel **DUCK** switch, which enables or disables ducking, and a description of the rear-panel DIP switches which provide options for modifying ducking behavior.

CHANNEL 6 STEREO INPUT

The mini stereo phone jack (1/8-inch TRS) provides a handy input for the signal from an MP3 player, phone or tablet. It is connected in parallel to the rear-panel stereo RCA phone jacks.

Refer to the **BLOCK DIAGRAM** on pages 10 and 11 for more information on how these connections are routed internally.

OPERATION

Front Panel Controls

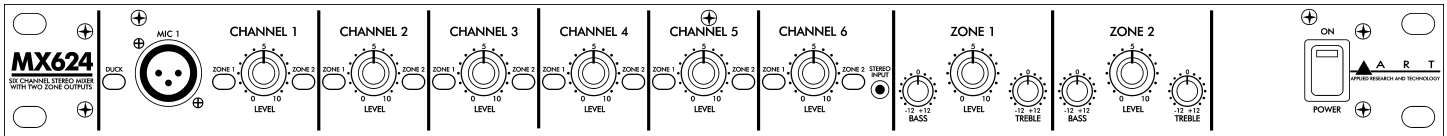

DUCK Switch

Pushing this switch in enables ducking in response to the signal from the MIC 1 input. Pushing this switch again returns it to the out position and disables ducking. The switch is illuminated by a red LED that is part of the ducking circuit, so it provides useful feedback about the amount of ducking applied as well as indicating basic on/off status.

With ducking enabled, the LED is dimly lit at the onset of ducking with relatively low level microphone signals. With higher level microphone signals, ducking becomes more fully engaged and the LED becomes brighter. Note that the LED lights briefly when power is first applied, even if there is no microphone signal or the switch is in the out (disabled) position. This power-on ducking helps prevent unwanted noise.

CHANNEL Controls (1-6)

LEVEL

Each of these controls adjusts the level of the associated input channel and determines its contribution to the overall mix. Unused inputs should have their associated level control turned off (**0** position or fully counterclockwise) to minimize potential stray noise pickup.

Keep in mind that the best noise performance, while keeping distortion to a minimum, is obtained with each control adjusted to the maximum desired level (towards **10**). In other words, in general, keep the **CHANNEL LEVEL** controls turned up and turn the **ZONE LEVEL** controls down to compensate, rather than the opposite.

ZONE 1 / ZONE 2 Assign Buttons

There are two zone assign buttons for each channel. When both of these buttons are in the out position, that channel's signal does not get routed to either zone. Pushing the **ZONE 1** button in assigns that channel's signal to Zone 1, where it is mixed with any other signals assigned to Zone 1. Pushing the **ZONE 2** button assigns that channel's signal to Zone 2, where it is mixed with any other signals assigned to Zone 2. Pushing both buttons in assigns that channel's signal to both zones. Pushing the buttons again returns them to the out position.

ZONE 1 and ZONE 2 Output Controls

LEVEL Control

This control adjusts the overall level of the mixed signal output to the **ZONE 1 OUT** and **ZONE 2 OUT (LEFT and RIGHT)** jacks.

BASS Control

This control adjusts the bass or low-frequency levels of the output signal. Turning the control fully counterclockwise applies the maximum bass cut (-12 dB). Turning the control fully clockwise applies the maximum bass boost (+12 dB). With the control in the center detent position, the bass response is flat.

TREBLE Control

This control adjusts the treble or high-frequency levels of the output signal. Turning the control fully counterclockwise applies the maximum treble cut (-12 dB). Turning the control fully clockwise applies the maximum treble boost (+12 dB). With the control in the center detent position, the treble response is flat.

POWER Switch

This switch turns the MX624 on and off. When the switch is pushed in at the top (**ON** position), a red LED in the switch lights, indicating that power is applied. Pushing the switch in at the bottom turns the unit off.

Rear Panel Controls

There is a group of ten DIP switches located towards the right end of the back panel, when viewed from the rear. These switches are nominally all in the up or **OFF** position. Their function is described below.

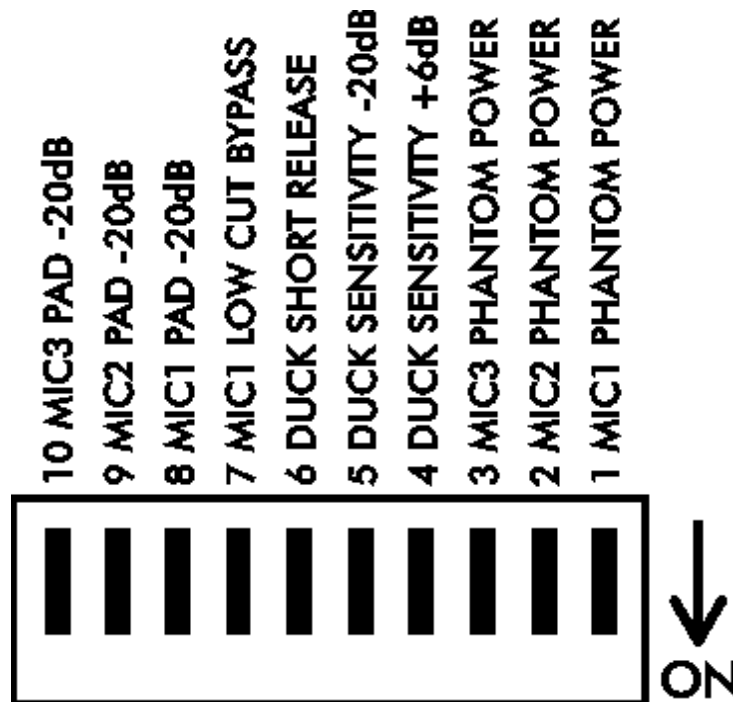

Rear Panel DIP Switches

MIC PHANTOM POWER Switches (1-3)

These numbered switches control the application of phantom power (+48V) to the corresponding numbered **MIC** XLR connectors. In the **OFF** position (up), no phantom voltage is applied. Moving the switch down (**ON** position) applies phantom voltage. Note that when phantom voltage is applied, the current supplied is limited to 7 mA for each leg of the balanced line.

DUCK Control Switches (4-6)

These switches allow you to alter the operation of the ducking action. The two sensitivity switches adjust the level which the signal from **MIC 1** needs to exceed for ducking to occur. Moving just switch 4 (**DUCK SENSITIVITY +6dB**) down (**ON** position) makes the ducking detector 6dB more sensitive, so that ducking occurs with a lower mic level. Moving just switch 5 (**DUCK SENSITIVITY -20dB**) down makes the ducking detector 20dB less sensitive, so that ducking occurs with a higher mic level. Both switches could be used together to make ducking 14dB less sensitive. Note that switch 8 (**MIC1 PAD -20dB**), discussed below, also affects the ducking level, making it another 20dB less sensitive.

Switch 6 (**DUCK SHORT RELEASE**), when in the **ON** position, makes the ducking circuit release more quickly, returning the output to normal levels in a shorter amount of time.

MIC Control Switches (7-10)

Switch 7 (**MIC1 LOW CUT BYPASS**), when in the **ON** position, removes the low-frequency roll-off normally applied to the Mic 1 signal. This roll-off is designed to remove subaudible noise, such as mechanical clicks and thumps, that might falsely trigger the ducking circuitry.

Switches 8 through 10 (**MIC1,2,3 PAD -20dB**), when in the **ON** position, pad the corresponding microphone input or make them 20dB less sensitive. This could be useful with high-output microphones to prevent overdriving or clipping the inputs. Note that the Mic 1 pad (switch 8) also affects the level applied to the ducking circuitry, as mentioned above.

BLOCK DIAGRAM

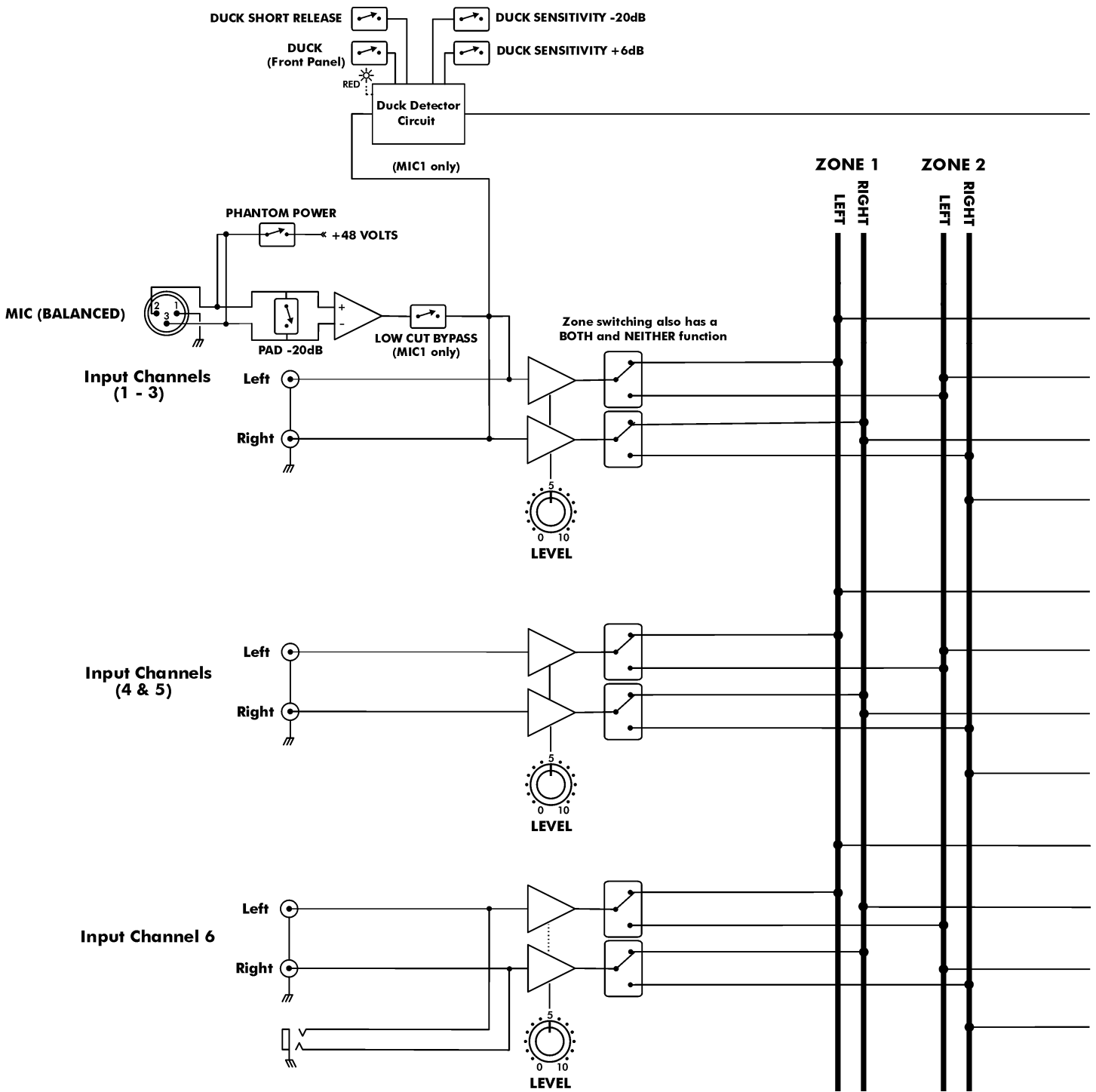

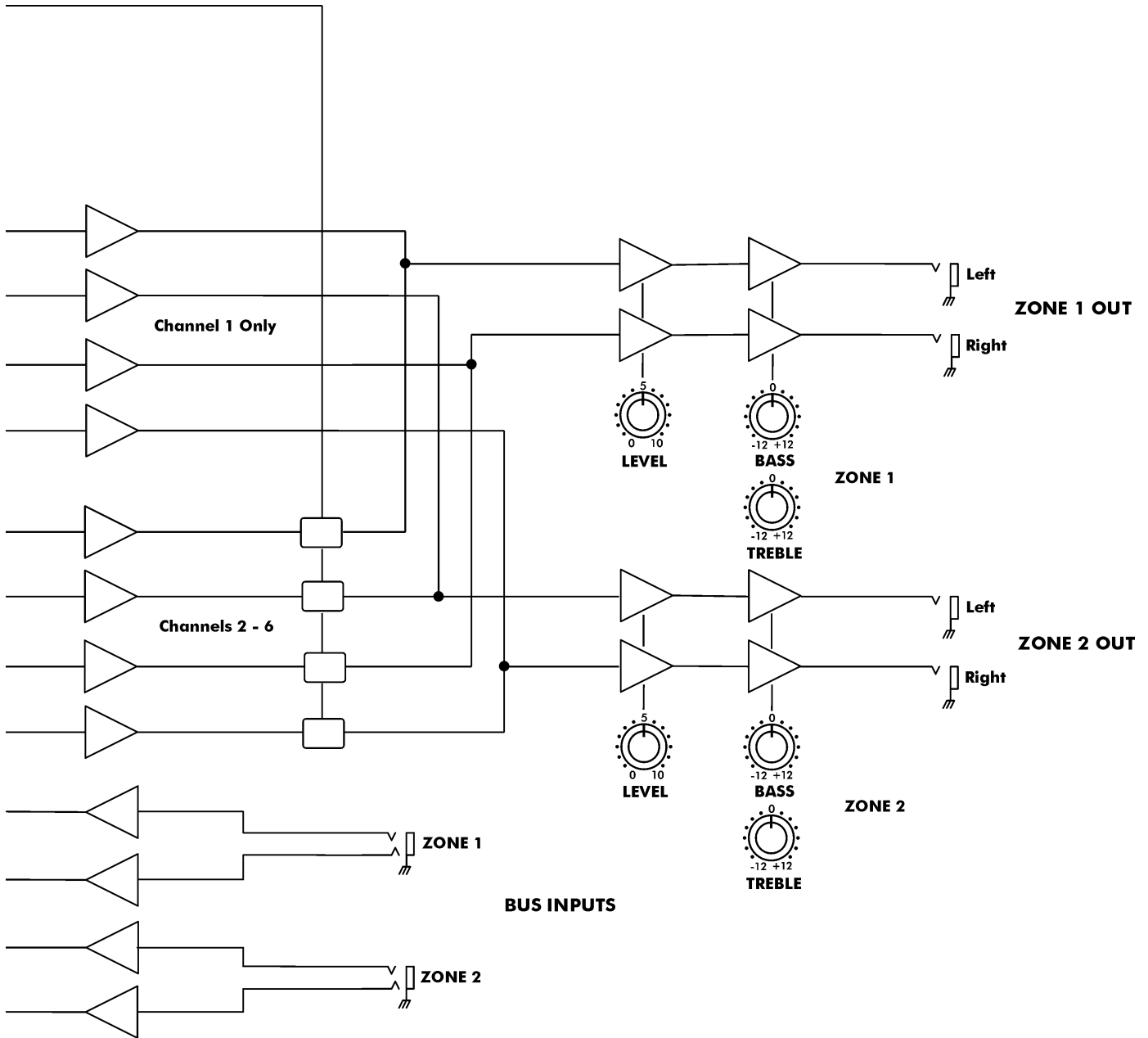

WARRANTY INFORMATION

Limited Warranty (USA only)

Applied Research and Technology will provide warranty and service for this unit in accordance with the following warrants:

Applied Research and Technology, (ART) warrants to the original purchaser that this product and the components thereof will be free from defects in workmanship and materials for a period of **three** years from the date of purchase. Applied Research and Technology will, without charge, repair or replace, at its option, defective product or component parts upon prepaid delivery to the factory service department or authorized service center, accompanied by proof of purchase date in the form of a valid sales receipt.

Exclusions

This warranty does not apply in the event of misuse or abuse of the product or as a result of unauthorized alterations or repairs. This warranty is void if the serial number is altered, defaced, or removed.

ART reserves the right to make changes in design or make additions to or improvements upon this product without any obligation to install the same on products previously manufactured.

ART shall not be liable for any consequential damages, including without limitation damages resulting from loss of use. Some states do not allow limitations of incidental or consequential damages, so the above limitation or exclusion may not apply to you. This warranty gives you specific rights and you may have other rights, which vary, from state to state. The warranty terms listed above are only valid within the United States of America.

For units purchased outside the United States, an authorized distributor of Applied Research and Technology will provide service. For information on warranty and service policies outside of the U.S., please contact your local distributor.

SERVICE

The following information is provided in the unlikely event that your unit requires service.

1. Be sure that the unit is the cause of the problem. Check to make sure that the unit has power supplied, that all cables are connected correctly, and that the cables themselves are in working condition. You may want to consult with your dealer for assistance in troubleshooting or testing your particular configuration.
2. If you believe that the ART unit is at fault, go to www.artproaudio.com. Select "Support", then "Return Authorization Request" to request a return authorization number.
3. If you are returning the unit for service, pack the unit in its original carton or a reasonable substitute. The original packaging may not be suitable as a shipping carton, so consider putting the packaged unit in another box for shipping. Print the RA number clearly on the outside of the shipping box. Print your return shipping address on the outside of the box.
4. Include with your unit: a note with the RA number and your contact information, including a return shipping address (we cannot ship to a P.O. box) and a daytime phone number, and a description of the problem, preferably attached to the top of the unit. Also include a copy of your purchase receipt.

Please fill in the following information for your reference:

Date of purchase: _____

Purchased from: _____

Serial Number: _____

SPECIFICATIONS

Input Connections	XLR female balanced (Mic, channels 1-3) RCA unbalanced (Line Inputs 1-6, Left & Right) 1/4-inch TRS unbalanced stereo (Bus Inputs, Zone 1 & 2)
Output Connections	1/4-inch TS unbalanced (Zone 1 & 2 Out, Left & Right)
Input Impedance	4k Ohms (Mic), 10k Ohms (Line), 10k Ohms (Bus)
Output Impedance	200 Ohms (Zone 1 & 2)
Frequency Response	20 Hz – 20 kHz (+0, -1 dB) (channels 1-6 in, zone out)
THD	<0.01% @ 1 kHz, typical
Phase Response	All connections are phase coherent
Signal to Noise Ratio	>90 dB typical (Ref 0dBu)
CMRR	>43 dB typical
Maximum Input Level	-4 dBu, +16 dBu with 20 dB pad (Mic), >25 dBu (Line)
Maximum Output Level	+20 dBu (unbalanced)
Maximum Gain	57 dB (Mic), 31 dB (Line)
Ducking Threshold	-49.5 dBv (adjustable via rear-panel dipswitches)
Ducking Depth	15 dB
Tone Controls	+/-12 dB @ 100 Hz & 10 kHz
Phantom Power	Switch selectable, +48V DC (regulated and filtered), 7 mA current limiting per leg
Power Requirements	USA: 85-125 VAC, 50-60 Hz, <15W Export units configured for country of destination
Dimensions (HWD)	1.75" x 19" x 6" 44.5mm x 483mm x 152mm
Weight	4.9 lbs. (2.2 kg)

Note: 0 dBu = 0.775Vrms

ART maintains a policy of constant product improvement. Therefore, specifications are subject to change without notice.

NOTES



www.artproaudio.com
E-mail: support@artproaudio.com

© 2015 Applied Research & Technology

MX624
624-5004-101
V1.0