

SB36W, SB36WE

Studio Boom Stands

- A. (1) Remove the chrome plated decorative shell (SB36W only - not included with SB36WE). (2) Do not adjust the check valve screw on the base until the upright tube is securely in position (see Figure #1). Place chrome shell in position on top of the base (SB36W only).
- B. Thread the upright tube assembly (3) securely into the base to avoid air leakage. Faulty operation of the air check-valve device on the underside of the base will be noticed if the upright tube is not installed tightly.
- C. Next the air check-valve screw, located on the underside of base, may be loosened or tightened for desired cushioning of the microphone stand tube assembly (see Figure #1).
- D. Attach three swivel casters onto the base using the lock washers, flat washers, and allen head bolts via the hex wrench provided (see Figure #2).
- E. Thread swivel adapter (4) on top of the installed upright $\frac{7}{8}$ " tube assembly. Next, install the swivel assembly (5) on top of the adapter. Tighten swivel assembly screw (6).
- F. Install counterweight (7) on unthreaded end of $\frac{7}{8}$ " boom tube (8), then insert threaded end through swivel assembly and attach coupler (9).
- G. Thread remaining boom tube (10) into the coupler. Next thread the hang-straight swivel (11) onto the end of the boom assembly.

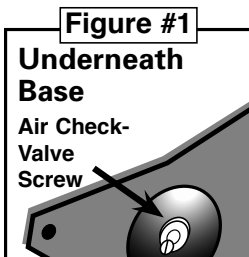
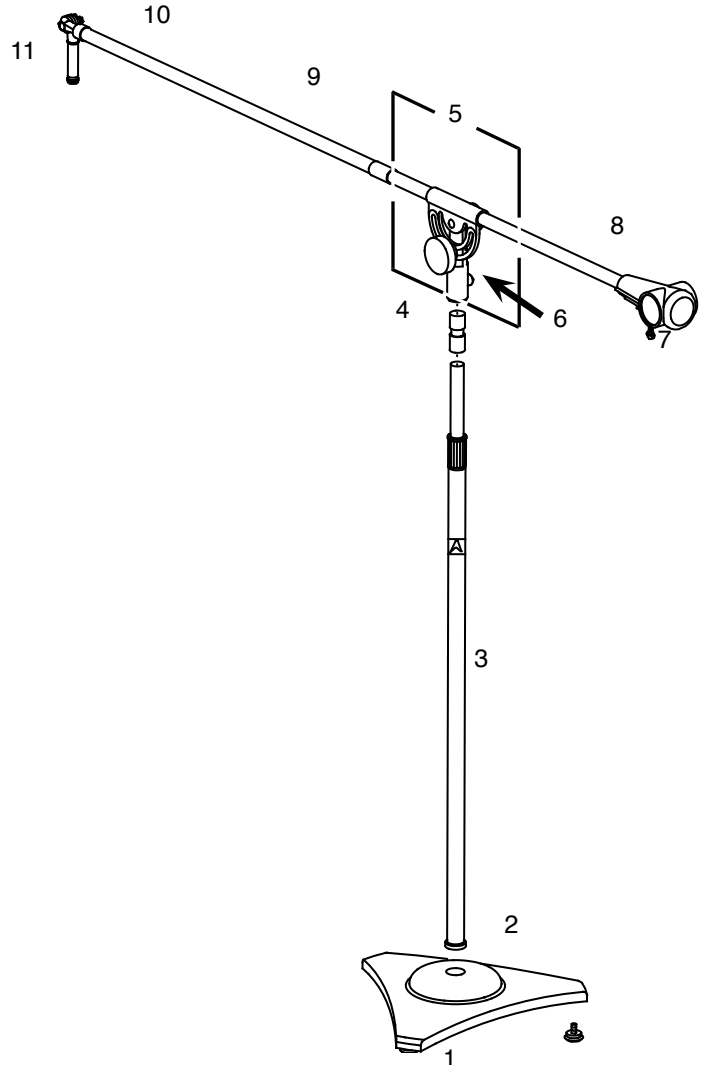

This can be adjusted for personal preference
 tightening the screw- increases resistance
 loosening the screw resulting in added
 friction on decreases resistance resulting in
 less friction on the clutch

