

# WMA Cabinets

## Wall Mounted Cabinets Series

### Concrete Wall Installation



Use  $\frac{3}{8}$ " x 2" sleeve type concrete anchor bolts for concrete walls or  $\frac{3}{8}$ " x 2" toggle bolts in concrete block wall applications. (1 bolt required per keyhole)

### Wood Stud Installation



Use  $\frac{5}{16}$ " x 2" lag bolts and washers. (1 bolt required per keyhole)

### Steel Stud Installation

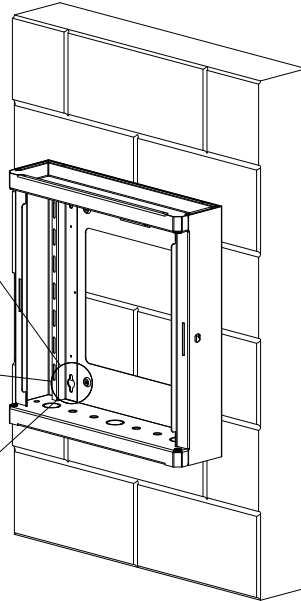

Use #10 sheetmetal screws and washers. (2 screws required per keyhole)  
(Steel stud installation not tested by UL)

**Figure 1**

All fastening and anchoring methods to be specified by site engineers/inspectors as required.

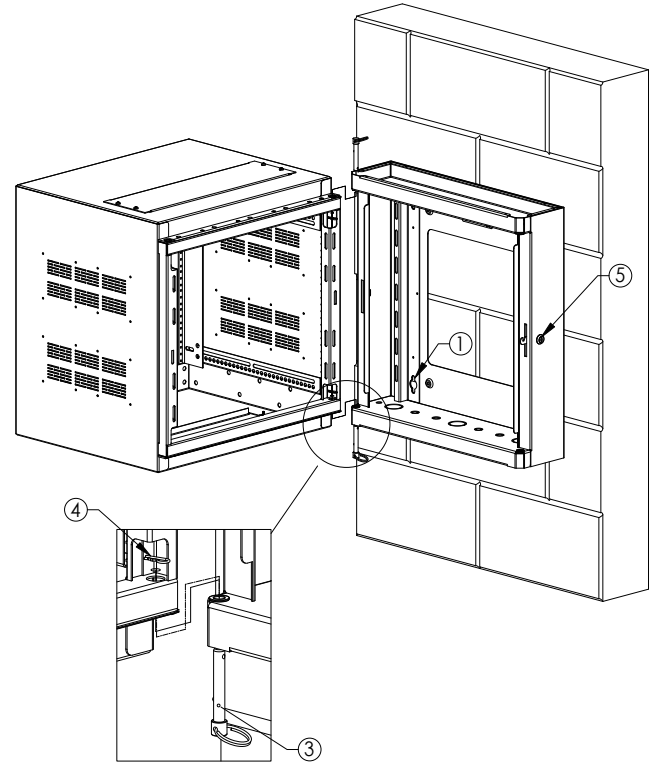
**Figure 2**

## Installation Instructions

1. Anchor backbox to wall through the reinforced areas shown above (Figure 1).
2. If the wall is uneven, shims may need to be positioned between the backbox and the wall to get the backbox level.
3. Determine the hinge side of the center section.
4. Install the hinge pins on the top and bottom of the side you wish to be hinged (Figure 2).
5. Open the center section and install the hair pins to prevent the hinge pins from being removed (Figure 2).
6. Leave adequate service loops in all wiring in case future change-over is required.

### Mounting Hole Locations

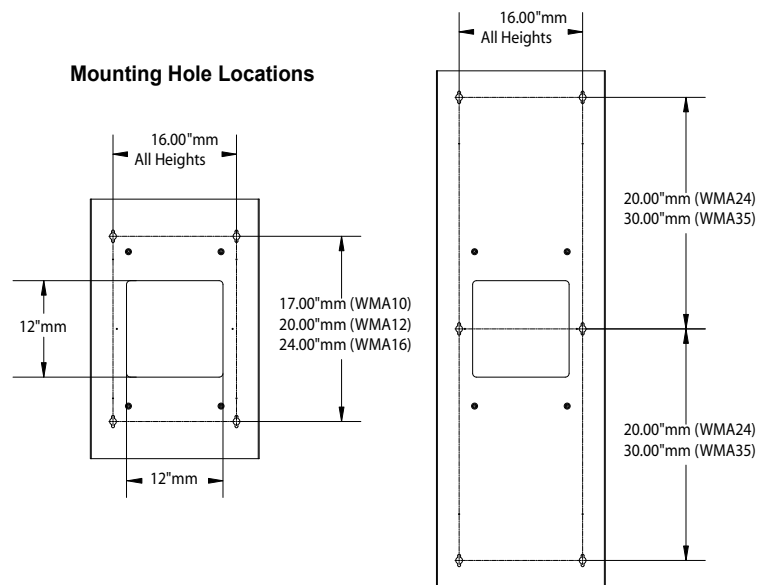

# WMA Cabinets

## Wall Mounted Cabinets Series

**Figure 3**
**CHANGE-OVER INSTRUCTIONS**

1. Open cabinet and remove the hair pins.
2. Close cabinet and leave in the locked position.
3. Remove the top hinge pin and re-install on the opposite side, Repeat this step on the bottom hinge pin (Figure 3).
4. Open cabinet, remove lock assembly and re-install on opposite side (Figure 3).
5. Re-install hair pins.

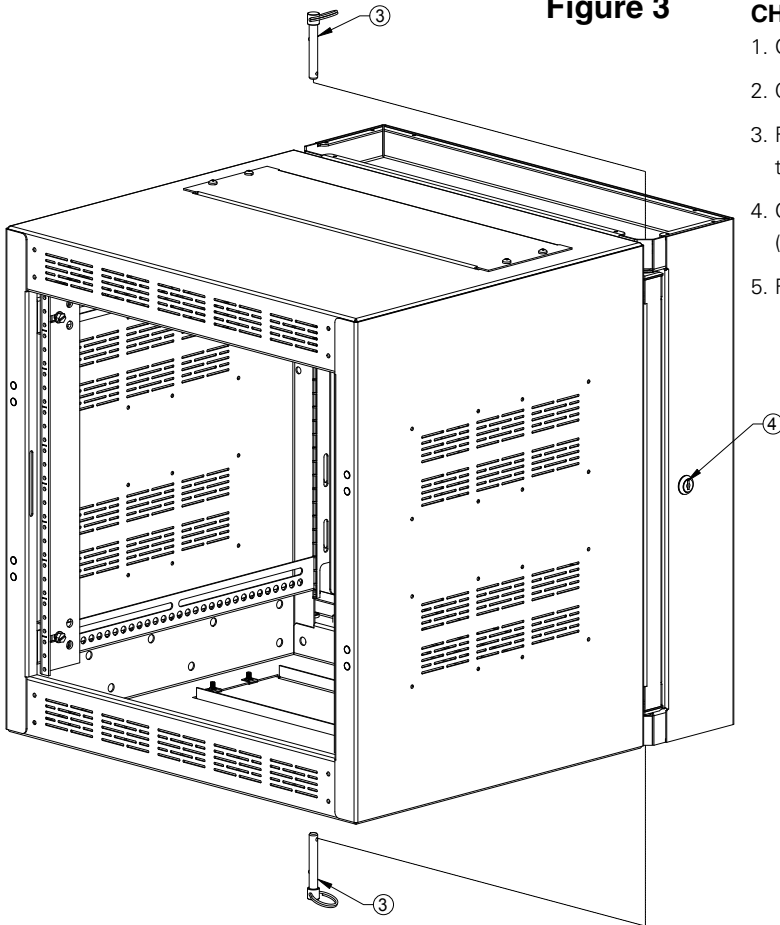
**Model**
**Weight Capacity**

WMA10-23	200 lbs
WMA12-23	200 lbs
WMA16-23	200 lbs
WMA24-23	300 lbs
WMA35-23	300 lbs