

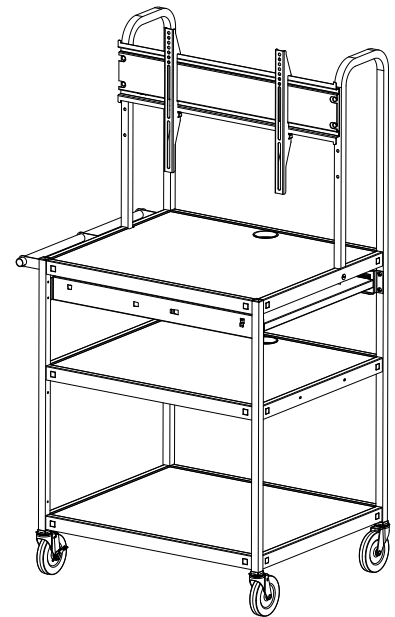

FP42UL FP42MUL
FP60UL FP60MUL

**FLAT PANEL CART WITH OR
WITHOUT A PULL OUT SHELF**



WARNING: FP42 carts are intended to hold monitors up to 75 lbs and FP60 carts are intended to hold monitors up to 100 lbs. The use of a TV monitor weighing more than that may result in instability causing possible injury. The top, middle and bottom shelves are intended to hold equipment up to 50 lbs. on each shelf. The pull out shelf on FP42MUL and FP60MUL is intended to support equipment up to 15 lbs.

PARTS LIST

Cart Models: FP42UL, FP42MUL, FP60UL & FP60MUL

Qty	Part#	Description
1	022-3065	Right Rear Leg Assembly
1	022-3066	Left Rear Leg Assembly
2	022-3067	Front Leg Assemblies
1	010-5778	Top Shelf - FP42 Models
	010-5794	Top Shelf - FP60 Models
1	010-5135	Middle Shelf - FP42 Models
	010-5795	Middle Shelf - FP60 Models
1	010-1892	Bottom Shelf - FP42 Models
	010-5796	Bottom Shelf - FP60 Models
1	022-2827	Handle Assembly
1	022-3068	Monitor Bracket - FP42 Models
	022-3091	Monitor Bracket - FP60 Models
2	010-4953	Hook Bars
2	010-4956	Stop Brackets
2	015-0017	5" Stem Casters w/o Lock
2	015-0018	5" Stem Casters with Lock

Pull Out Shelf Models : FP42MUL & FP60MUL

Qty	Part#	Description
2	010-5783	Shelf Brackets - FP42 Models
	010-5784	Shelf Brackets - FP60 Models
1	010-5782	Pull Out Shelf
1	030-1468	Left Outer Slide
1	030-1470	Right Outer Slide
2	030-1471	Inner Slides

Electrical Unit Models : FP42UL-E5BK, FP42MUL-EBK,
FP60UL-E5BK & FP60MUL-E5BK

Qty	Part#	Description
1	E6 UNIT	6-Outlet Electrical Unit

HARDWARE LIST

Part#	Description
030-0300-10T	5/8" Square Head Bolts
030-0002	5/16-18 Hex Serrated Nuts
030-1349	5/16-18 x 3/4" Hex Hd Screws
SC1048B	1/4-20 x 45mm Bolts
030-0207	1/4-20 Serrated Flange Nuts
030-0401	5/8-18 x 1 1/2" Hex Head Screws
030-0411	5/16-18 Serrated Nuts
030-0304	1/4-20 X 5/8" Combo Truss Hd Screws
030-0865	#6 x 1/2" Button Pin-In Hd Screws
030-0354	10-32 x 1 1/2" Button Sockets Screws
010-1106	Hex Wrench
030-1352	1/8" Security Pin-In Driver Bit
044-2124	Courtesy Hardware Pack
	<u>This Pack Consists of:</u>
	(4) Metric M4 x 12 Screws
	(4) Metric M4 x 30 Screws
	(4) Metric M5 x 12 Screws
	(4) Metric M5 x 30 Screws
	(4) Metric M6 x 12 Screws
	(4) Metric M6 x 35 Screws
	(8) Small Washers
	(20) Large Washers
	(4) 5/8" Large Spacers

STEP 1

Position the top shelf onto the rear legs making sure the leg brackets are to inside of the shelf. **LOOSELY** secure the shelf to the legs using screws (AA) and bolts (BB).

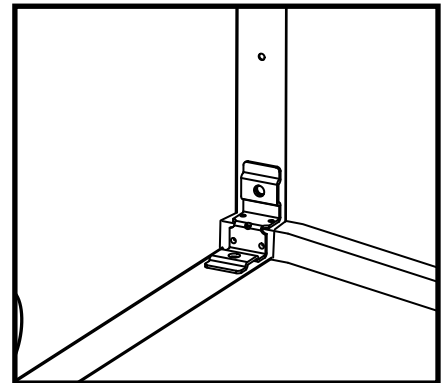
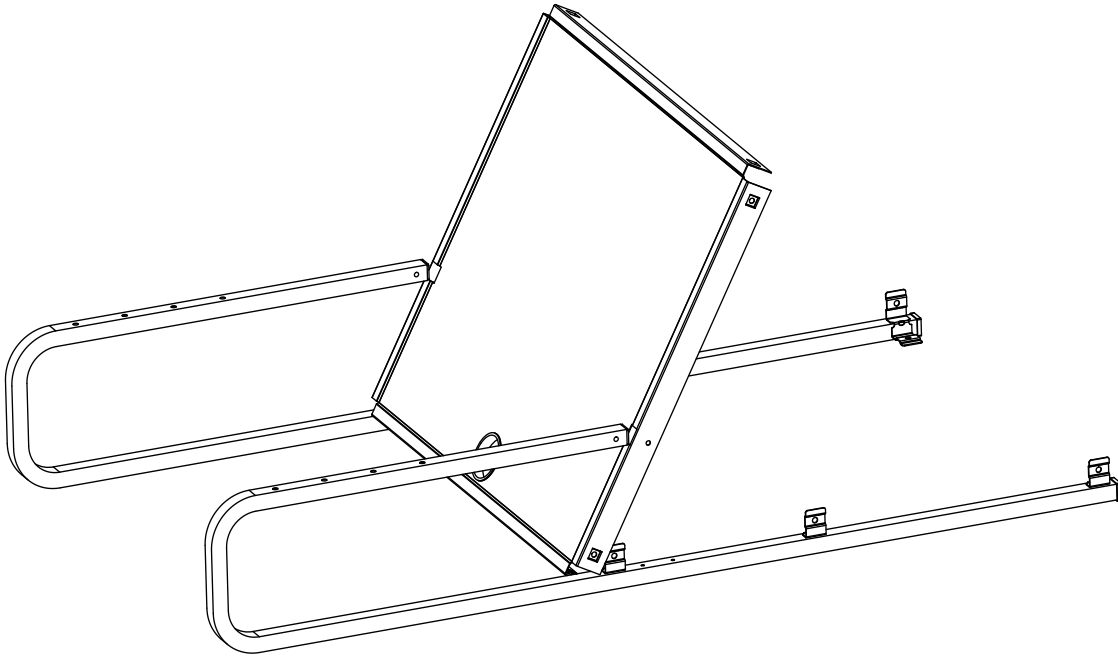

BRACKET TO THE INSIDE

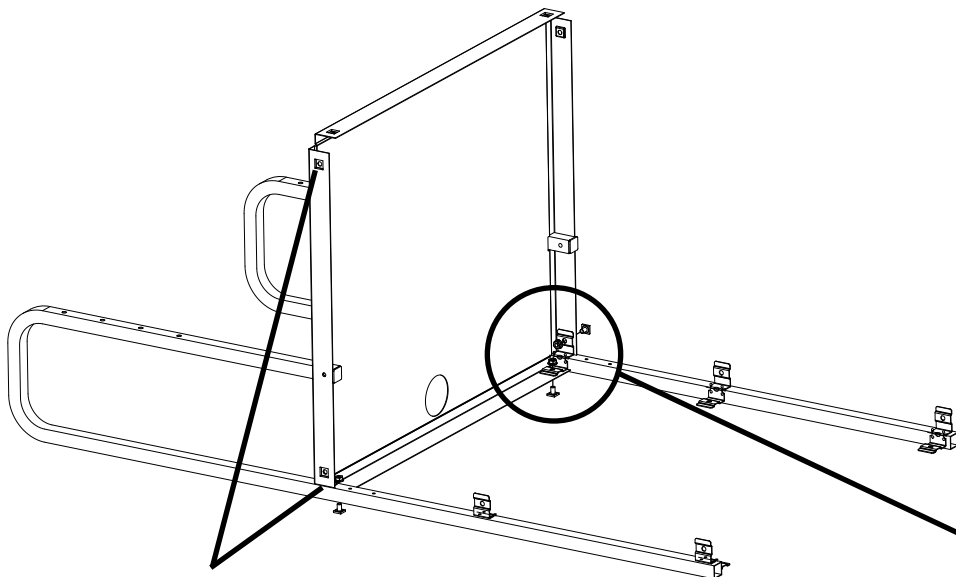
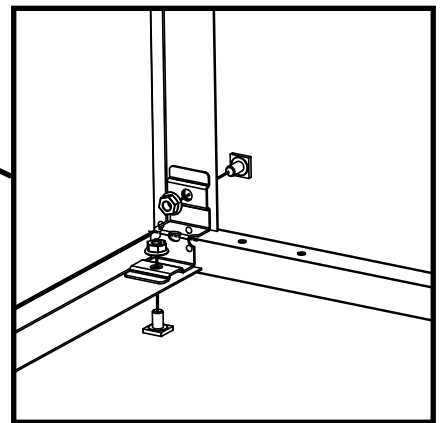

These side holes are used for installing the handle. Leave one of the sides open to install the handle.



AA



BB

STEP 2

Slide the middle and bottom shelves onto the rear legs. Slide the front legs on. **LOOSELY** install hardware to each corner, remembering to leave access for the handle.

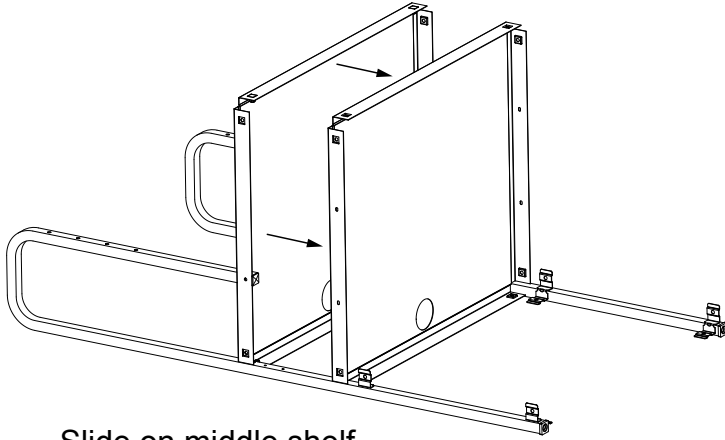

Slide on middle shelf.

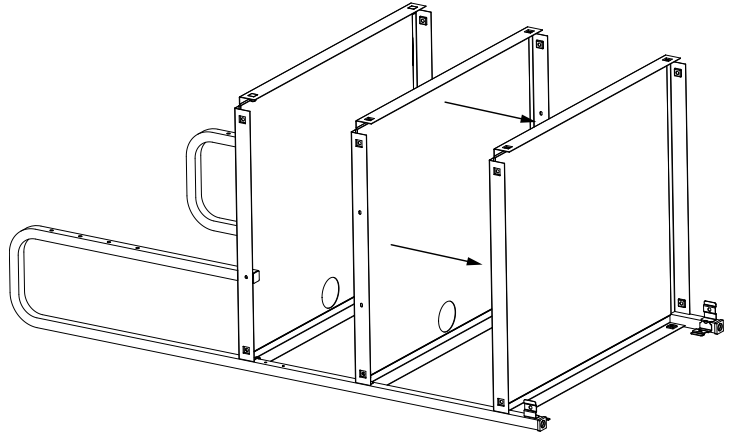

Slide on bottom shelf.

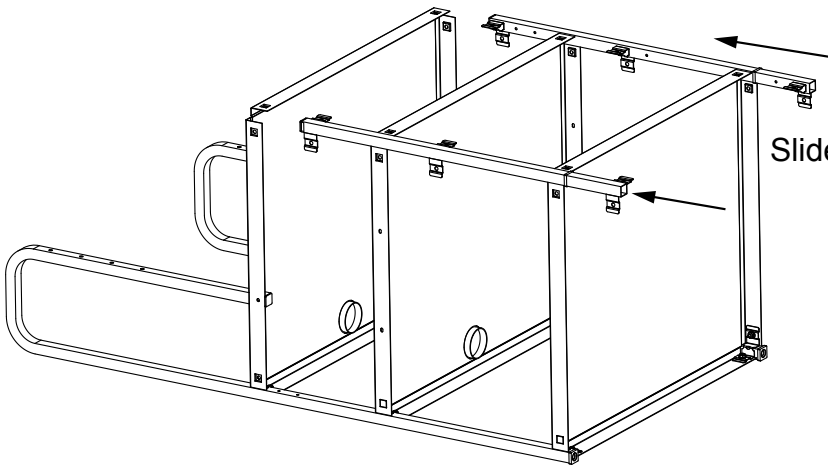

Slide on front legs.

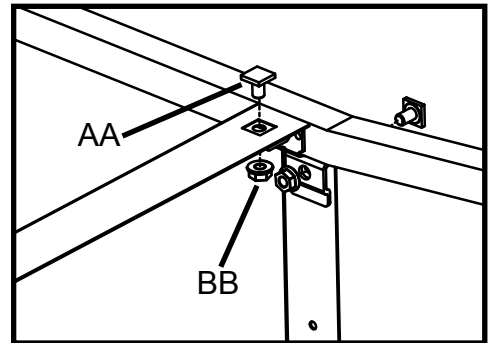

INSTALL HARDWARE TO EACH CORNER, OMIT HANDLE SIDE

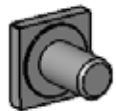

AA



BB

STEP 3

Install handle to either side of the cart using bolts (CC) and nuts (BB).

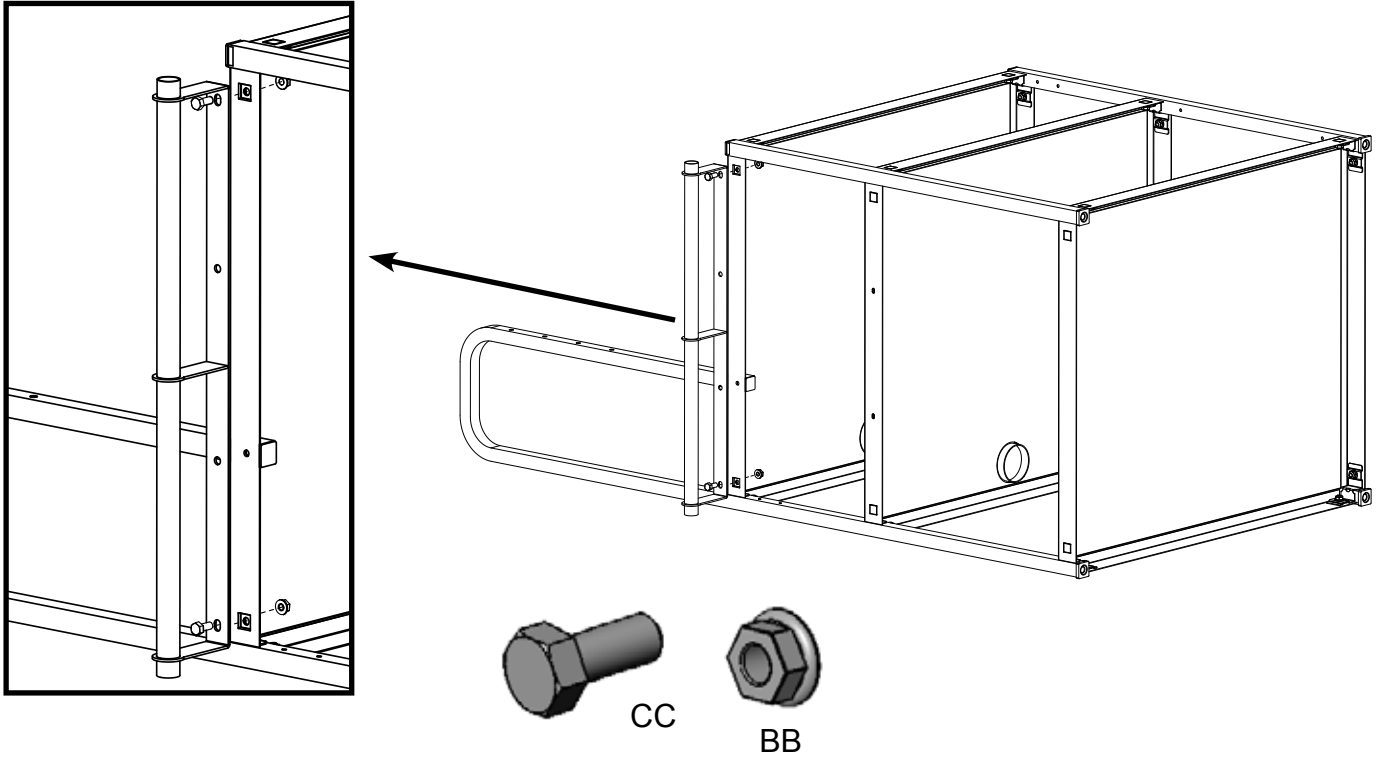

STEP 4

Secure tube and top shelf together using screws (DD) and nuts (EE).

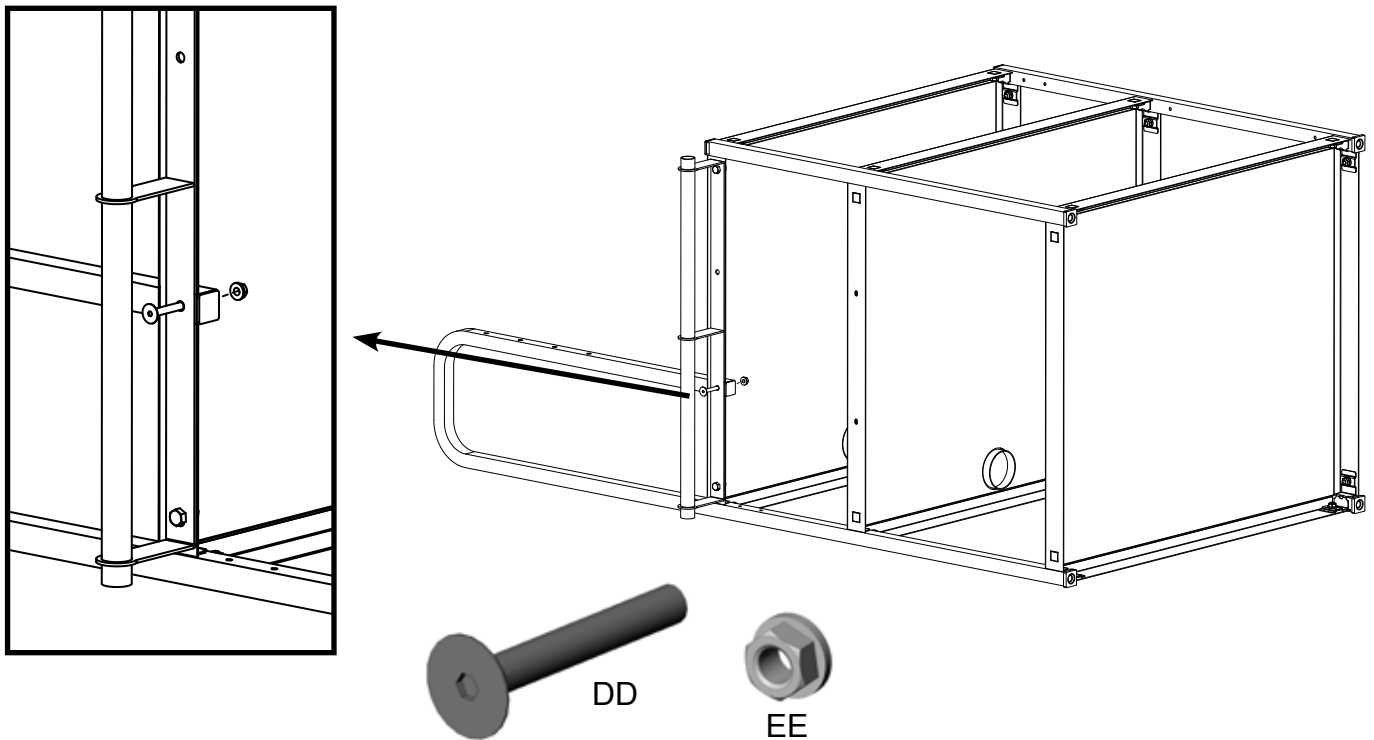

NOW TIGHTEN ALL CART CORNER HARDWARE

STEP 5

Push a caster into each leg insert. To ensure casters are securely in place, a rubber mallet may be used to tap them in place. **NOTE:** The locking casters **MUST** be installed on the same side as the handle.

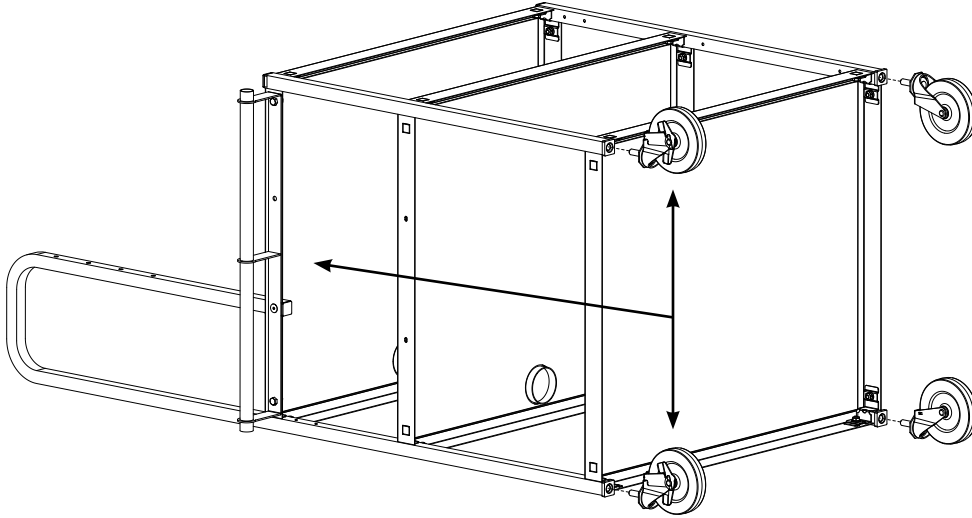

STEP 6

Attach the monitor bracket onto the front of the rear leg tubes as shown using bolts (FF) and nuts (GG).

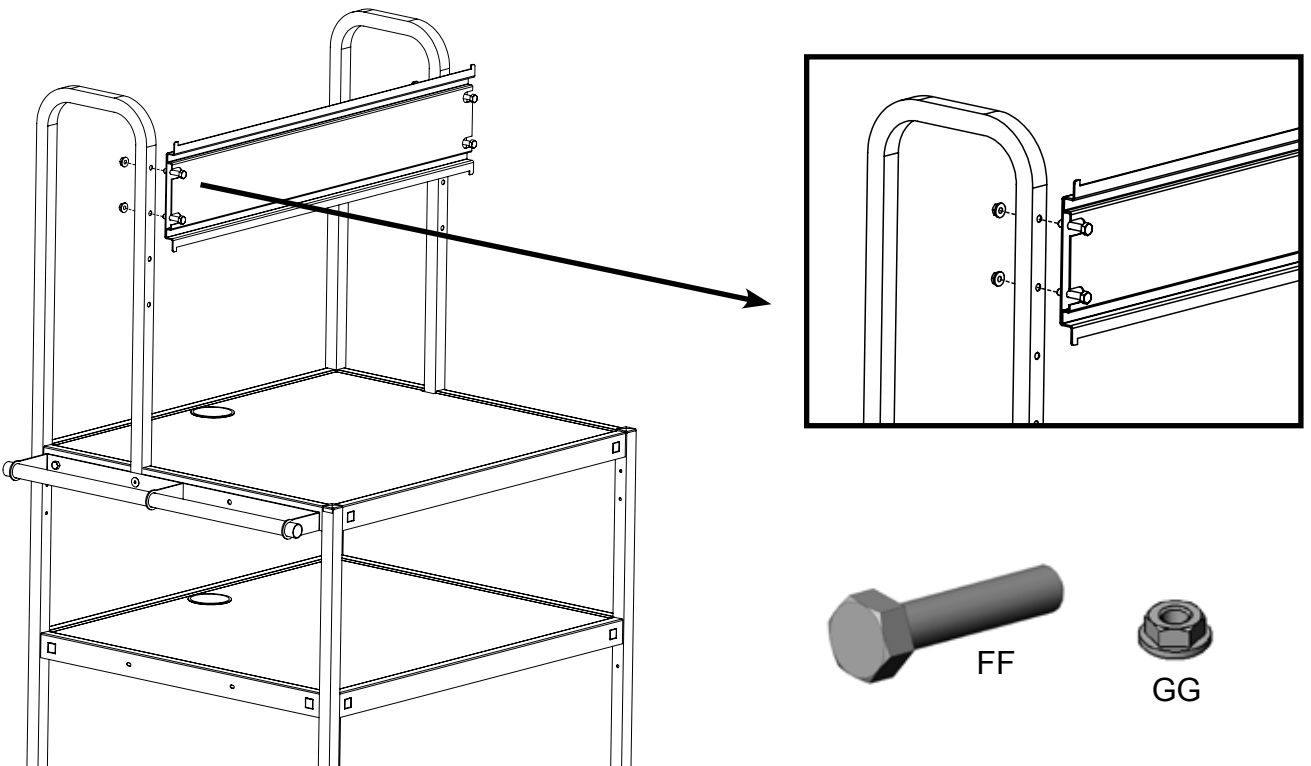

SKIP TO STEP 12 IF YOUR CART DOES NOT HAVE A SHELF

STEP 7

Attach each shelf bracket under the top shelf as shown using screws (HH).

Make sure the bracket cutouts face this way, if not the bracket will be installed upside down.

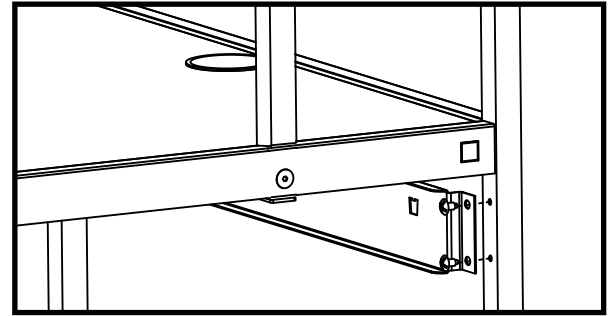
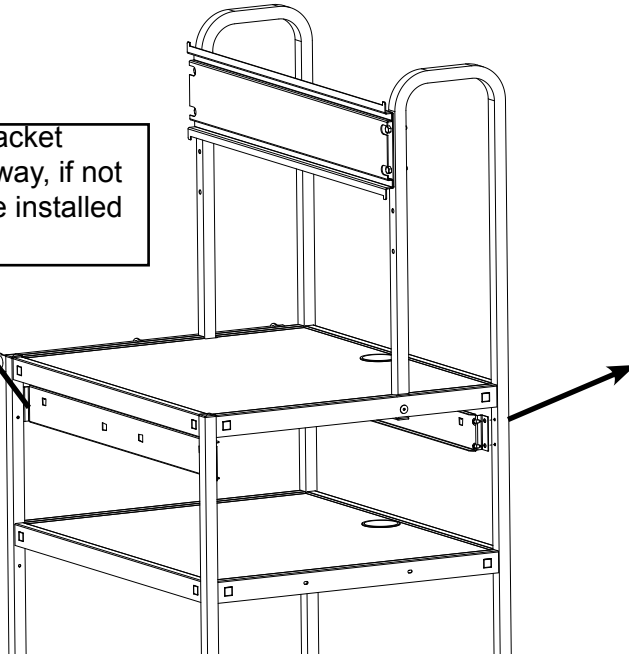

STEP 8

Install the outer slide onto the shelf bracket by sliding TAB 1 into CUTOUT A and TAB 2 into CUTOUT B. The pull out shelf should be installed opposite of the handle.

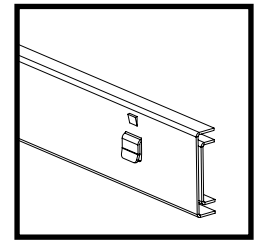
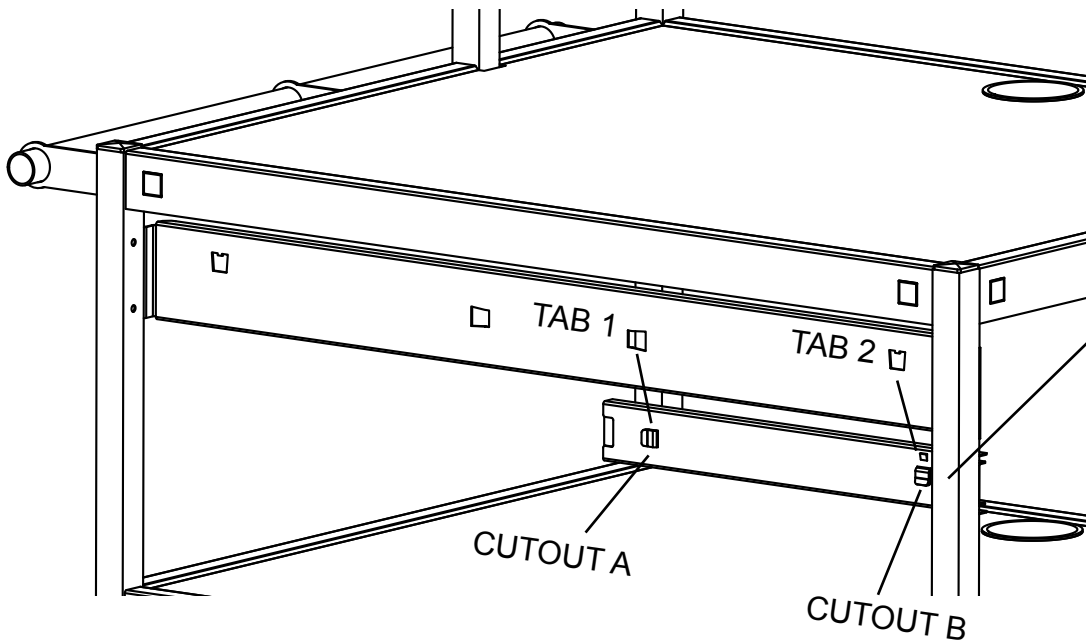

This tab determines where the shelf will slide out from.

Each cart bracket has additional cutouts to allow the shelf to pull out from either side of the cart.

NOTE: Some bend in the bracket is ok as the slides and shelf will take care of that once they are installed.

STEP 9

Install each inner slide into the outer slides. **NOTE: Push inner slide in all the way until it snaps in.**

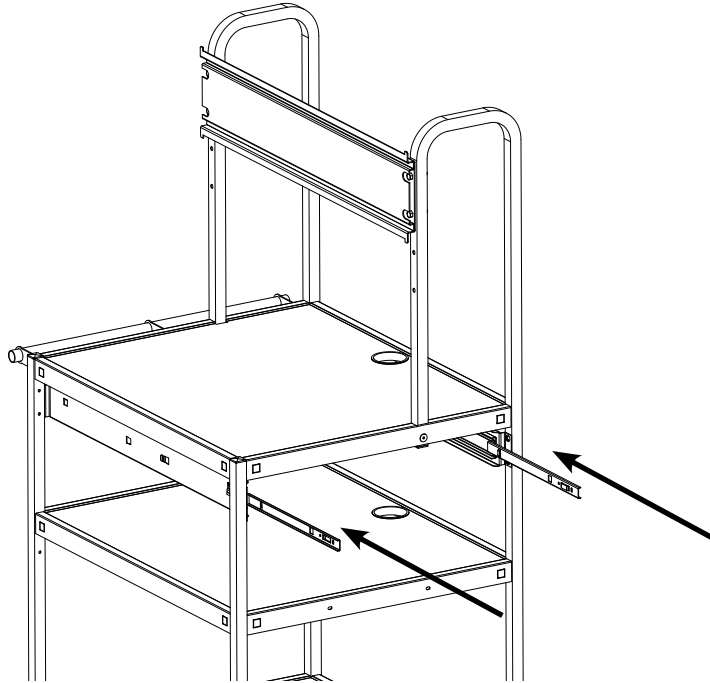

STEP 10

Extend the slides to the positioning shown.

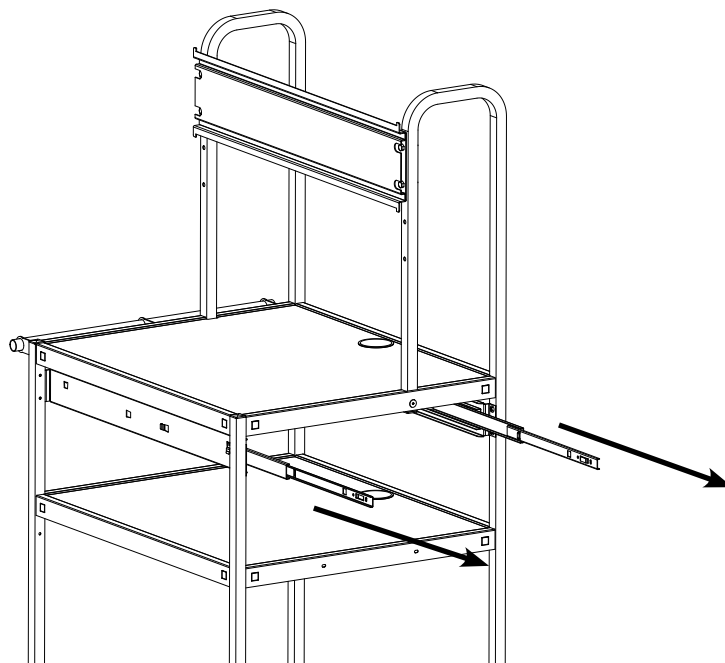

STEP 11

Install the pull out shelf by sliding **CUTOUT 1** into **TAB 1** and **CUTOUT 2** into **TAB 2**.

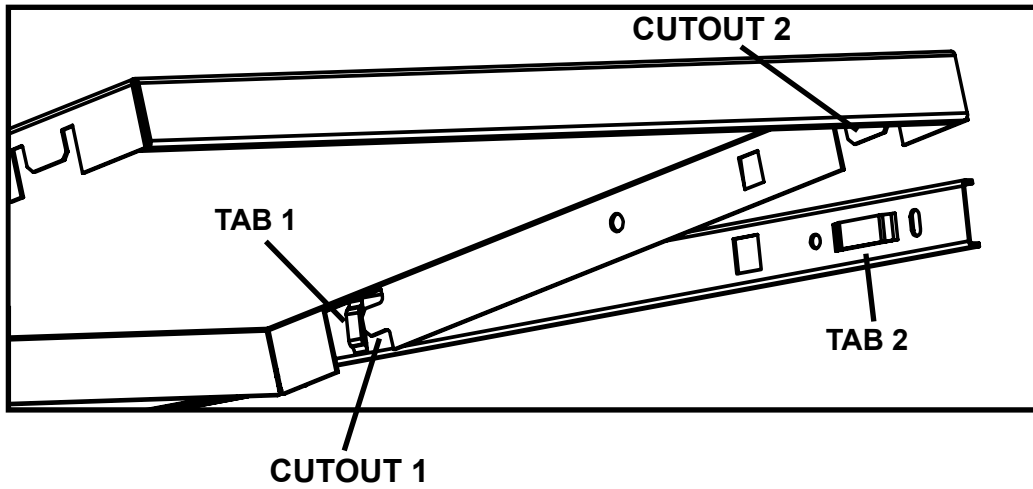
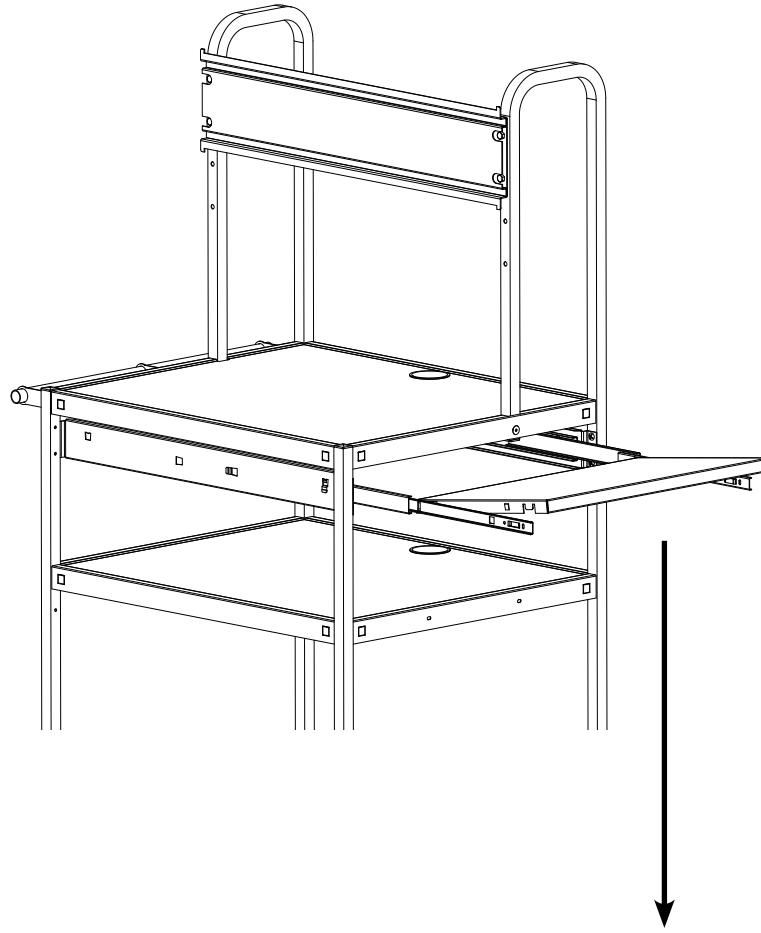

STEP 12

Attach both hook bars onto the back of your monitor using the mounting holes built into the case. A courtesy hardware pack has been provided with several metric screw sizes. You may need to purchase additional metric screws from your local hardware store for odd shaped monitors.

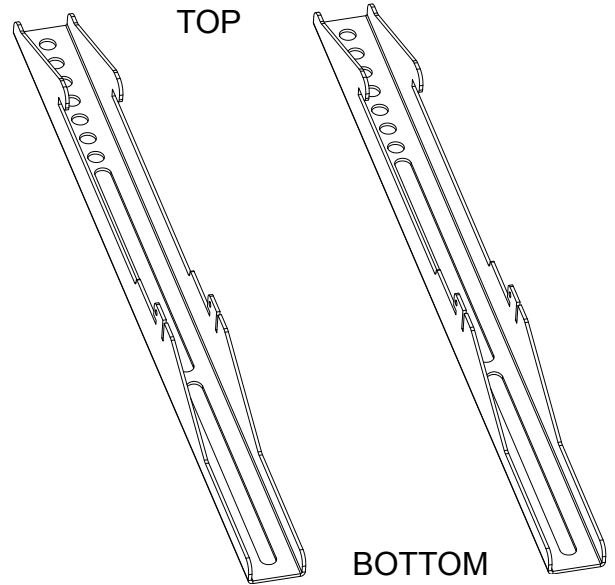

STEP 13

With someone's help, hook your monitor onto the bracket as shown. (Monitor removed from picture for clarity.)

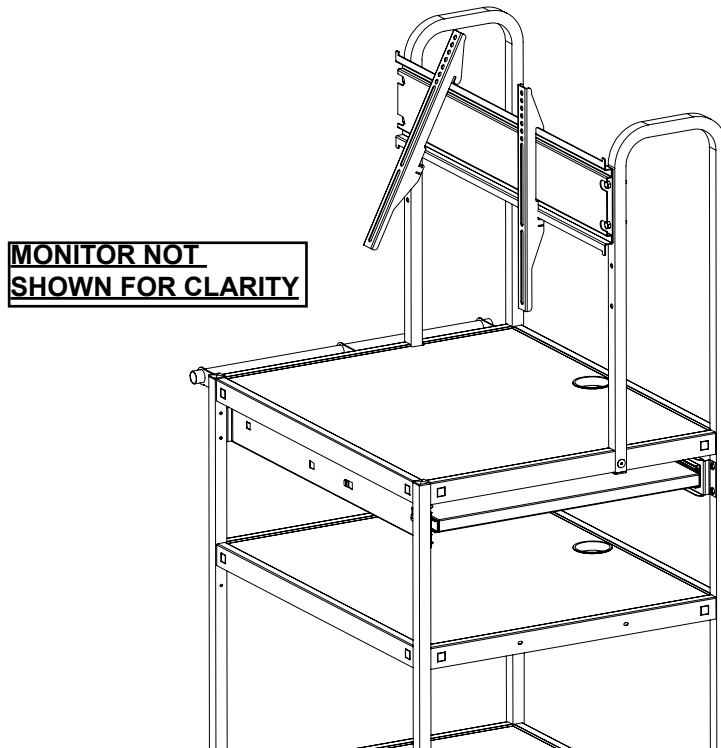

STEP 14

Attach the stop brackets to the hook bars as shown with security screws (II) using the driver bit provided.

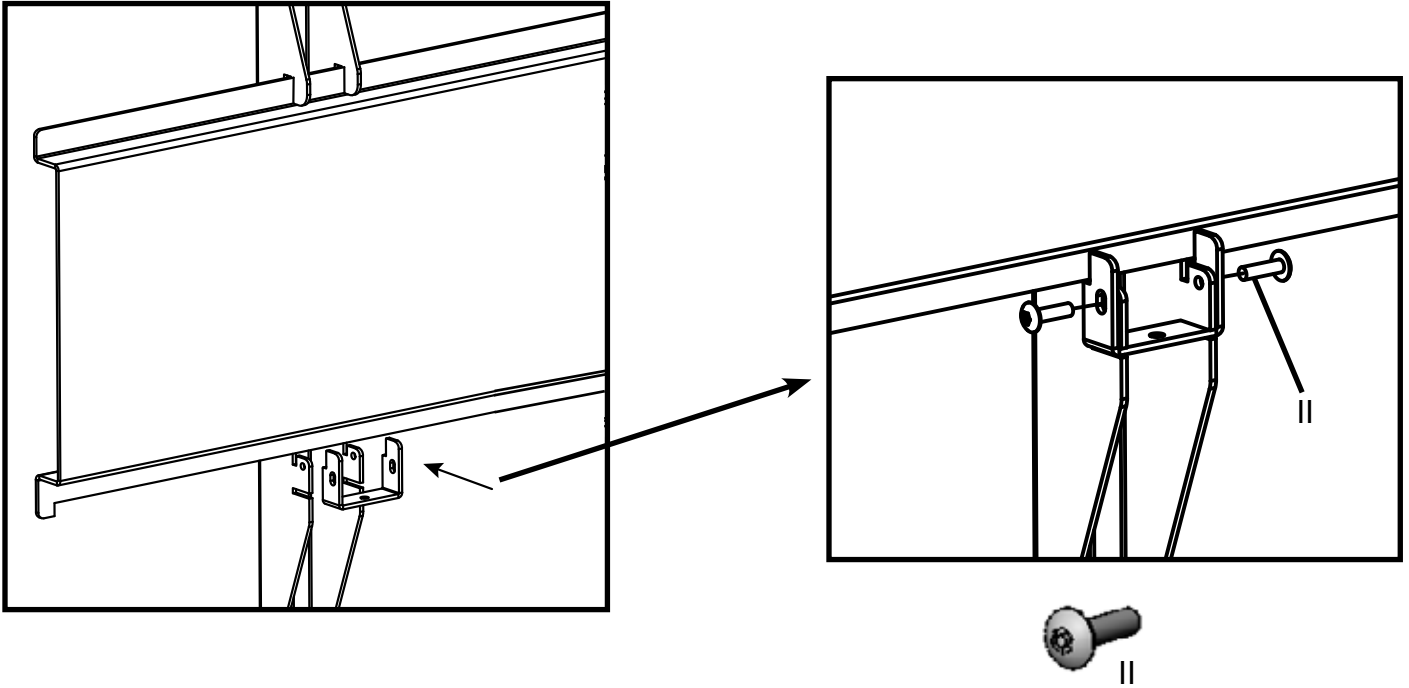

STEP 15

Center your monitor horizontally and then tighten in place with screws (JJ).

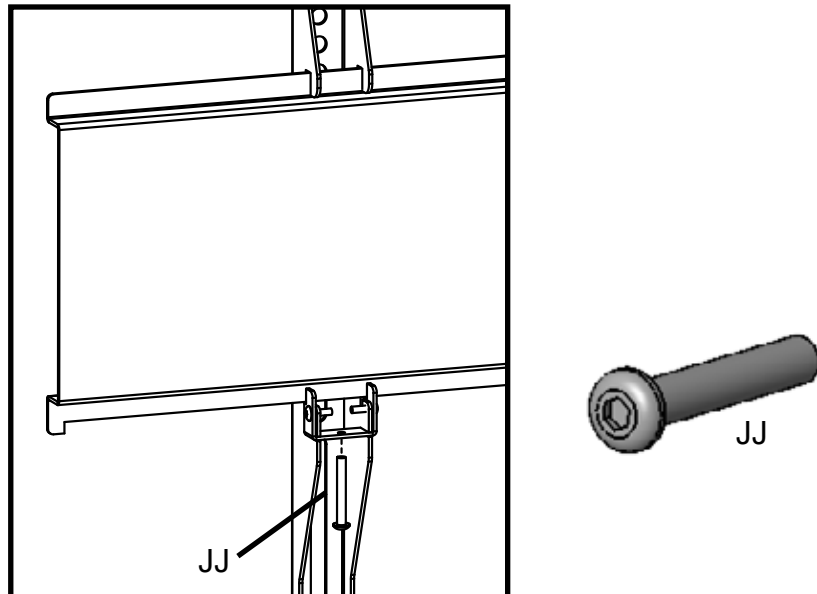

CENTER MONITOR HORIZONTALLY THEN SECURE

Bretford
11000 Seymour Avenue
Franklin Park, IL 60131
TEL: 847.678.2545
800.521.9614
FAX: 847.678.0852
800.343.1779

Bretford Ltd.
2 Etongate
110 Windsor Road, Slough
Berkshire SL1 2JA England
TEL: 011 44 17 5353 9955
FAX: 011 44 17 5353 9478

www.bretford.com