

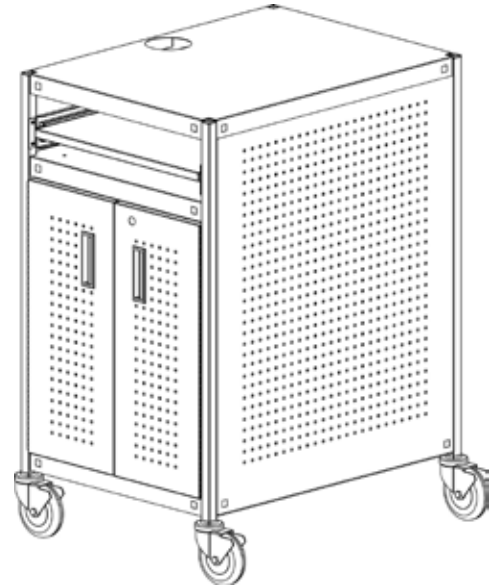

## TC15 / TC15FF

### 19" RACK PRESENTATION CART WITH & WITHOUT POWER

#### Assembly Instructions



#### PARTS LIST

| Qty  | Part#    | Description                   | Ref |
|------|----------|-------------------------------|-----|
| 2    | 022-2708 | Leg Assembly Stamped with "X" | AA  |
| 2    | 022-2709 | Leg Assembly Stamped with "O" | BB  |
| 1    | 022-2695 | Top Shelf w/Grommet Hole      | CC  |
| 1    | 022-2699 | Middle Shelf w/Grommet Hole   | DD  |
| 1    | 010-4791 | Bottom Shelf                  | EE  |
| 2    | 010-4785 | Slide Bracket                 | FF  |
| 2    | 030-1191 | Slide                         | GG  |
| 2    | 010-5053 | Keyboard Shelf                | HH  |
| 1    | 010-4788 | Front Panel                   | II  |
| 1    | 010-4789 | Rear Panel                    | JJ  |
| 2    | 022-2697 | Left Door Assembly            | KK  |
| 2    | 022-2698 | Right Door Assembly           | MM  |
| 1pr. | 030-1206 | Rack Rail                     | NN  |
| 4    | 010-4799 | Rail Bracket                  |     |
| 2    | 010-4867 | Utility Shelf                 |     |
| 2    | 015-0002 | 4" Caster w/o Brake           |     |
| 2    | 015-0003 | 4" Caster w/ Brake            |     |
| 1    | E12      | Electrical Unit - TC15FF ONLY |     |

#### HARDWARE LIST

| Qty | Part#        | Description                        |
|-----|--------------|------------------------------------|
| 24  | 030-0300-10T | 5/8" Square Head Bolts             |
| 24  | 030-0002     | 5/16-18 Hex Serrated Nuts          |
| 36  | 030-0325     | 1/4-20 x 1/2" Combo Screws         |
| 16  | 030-0240     | 1/4" External Lockwashers          |
| 16  | 030-1228     | 8-32 x 1/4" Combo Truss Hd Screws  |
| 8   | 030-1203     | #8-32 Acorn Nuts                   |
| 10  | 02236        | 8-32 Hex Flange Nuts               |
| 4   | 030-0023     | #6-32 x 3/8" Rnd Hd Machine Screws |
| 4   | 030-0522     | 6-32 Locknuts                      |
| 8   | 030-0256     | 1/4-20 Flange Nuts                 |
| 2   | 030-0302     | #8-32 x 3/8" Screws - TC15FF ONLY  |
| 8   | 030-0402     | #10-32 x 5/8" Combo Screws         |
| 8   | 030-0383     | #10 x 1/2" "AB" Truss Hd Screws    |
| 1   | 010-1106     | Hex Wrench                         |
| 2   | 010-1188     | Door Stop Brackets                 |
| 4   | 012-0286     | Plastic Door Handles               |

#### TOOLS REQUIRED

Hex Wrench (Provided)  
Phillips Screwdriver  
Rubber Mallet

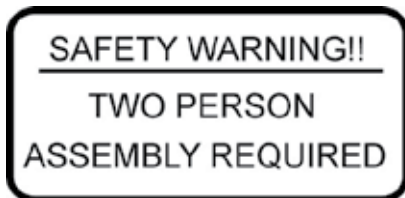

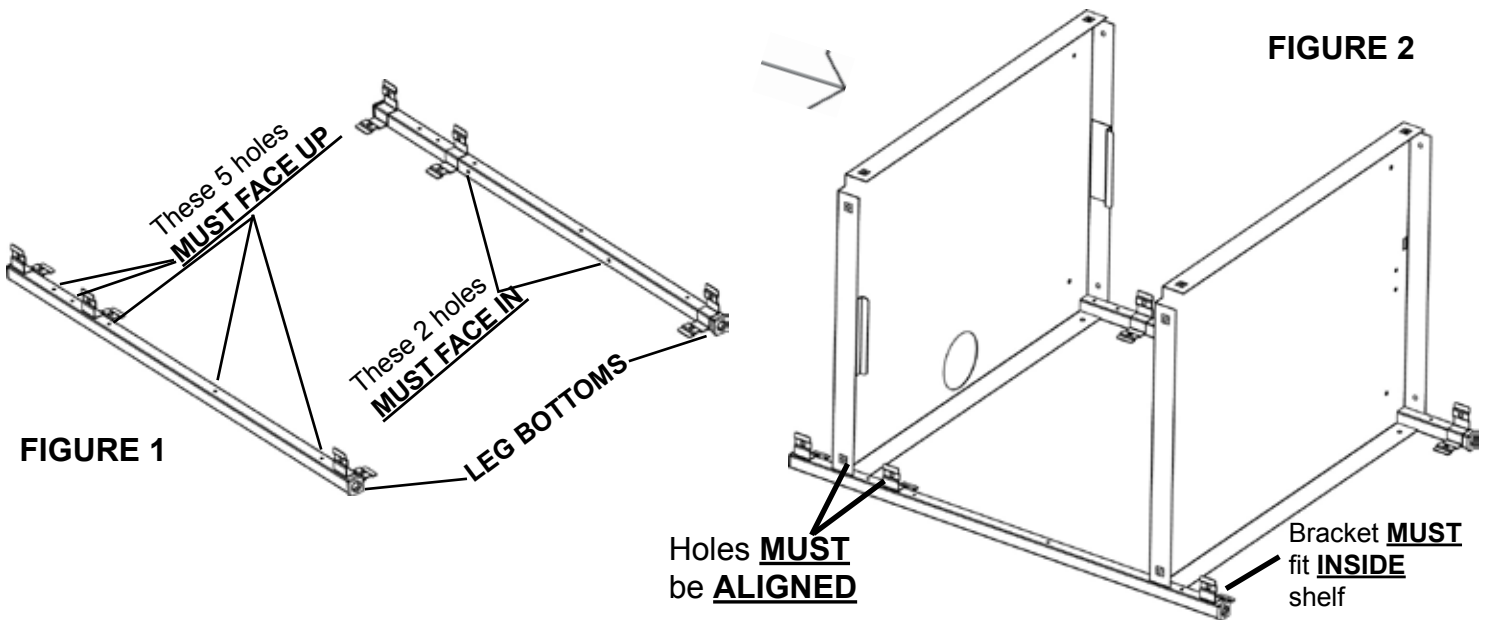

### STEP 1

Lay the rear legs on a carpeted surface exactly as shown in **FIGURE 1**. Slide bottom and middle onto the legs so that the brackets are inside the shelves as shown in **FIGURE 2**.

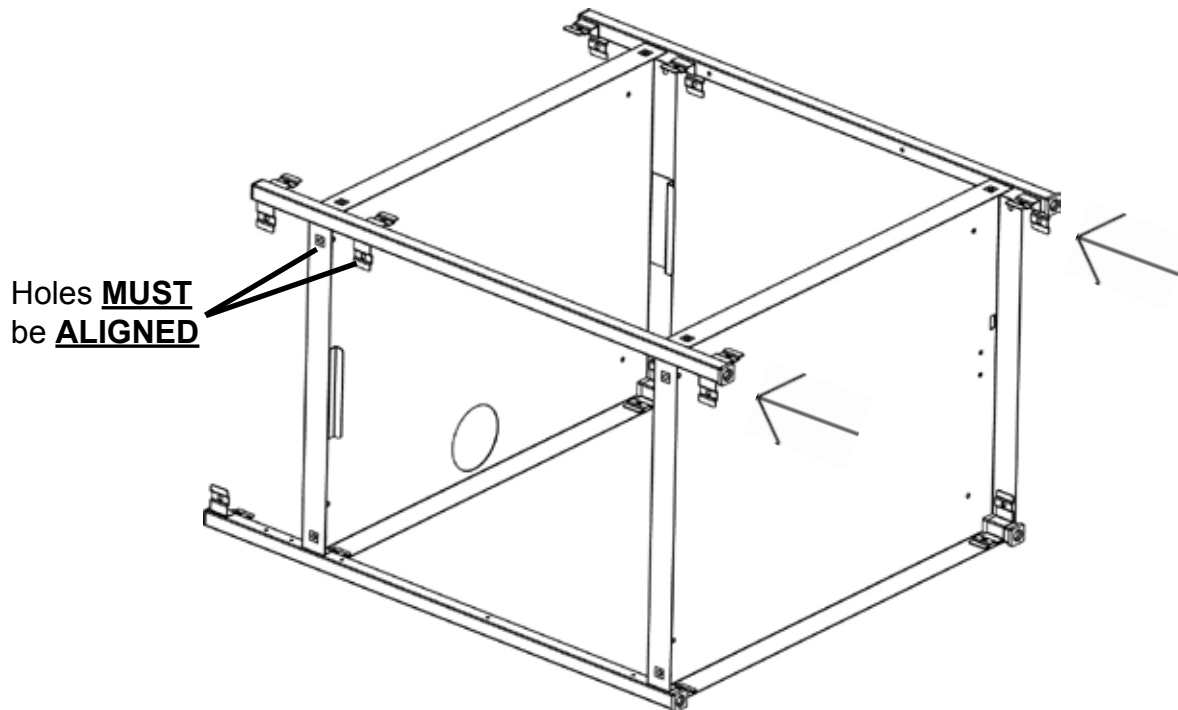

### STEP 2

Slide the front legs onto the shelves so that the brackets are inside the shelves as shown. **NOTE:** Make sure all bracket holes are aligned with the shelf holes.

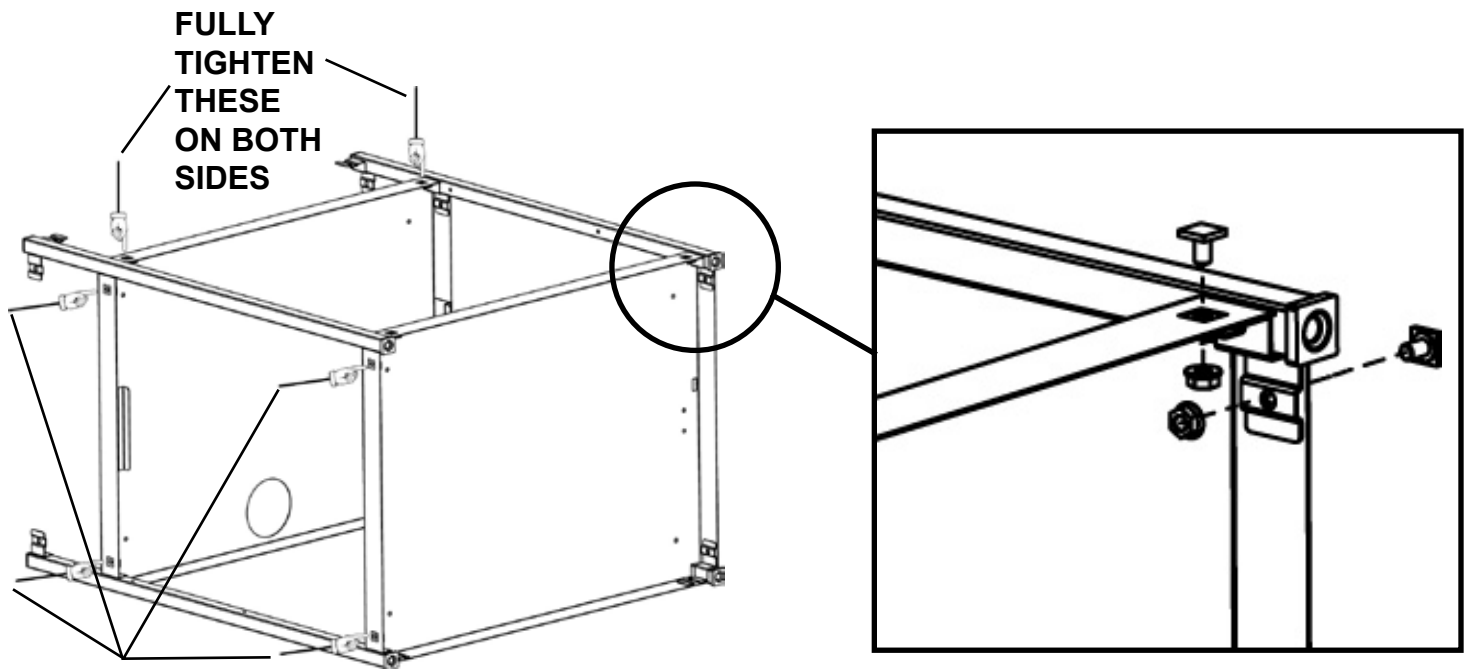

**ONLY INSTALL IN THESE LOCATIONS BOTH SIDES**

**STEP 3**

**HAND TIGHTEN** shelves and legs with bolts (AA) and nuts (BB). **ONLY** install side hardware and middle shelf hardware as indicated. **FULLY TIGHTEN MIDDLE SHELF HARDWARE.**

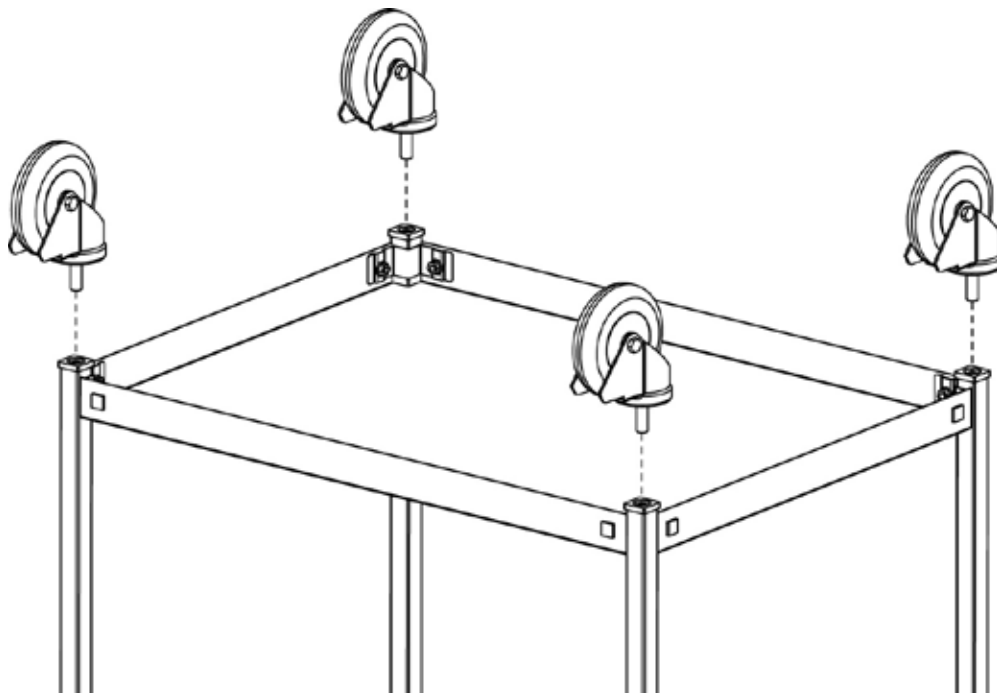

**STEP 4**

Insert each caster into the bottom of each leg. If caster does not insert easily, use a rubber mallet to tap caster in place. Once casters are **SECURELY** in place, stand unit upright.

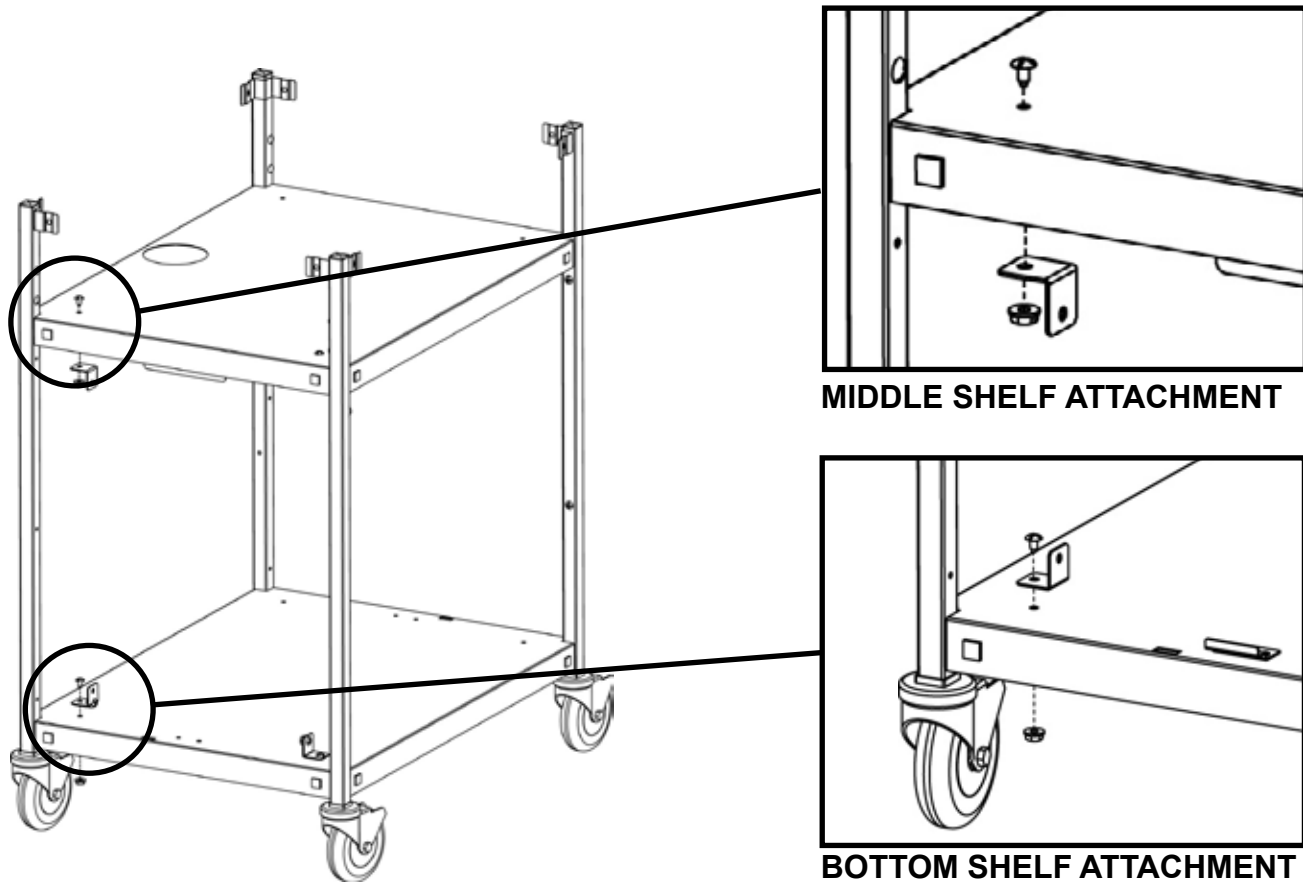

**MIDDLE SHELF ATTACHMENT**

**BOTTOM SHELF ATTACHMENT**

**STEP 5**

Attach L-brackets to one side of the cart. These should be mounted on the side that you wish the utility shelves to be installed on. Attach each bracket (2 per shelf) with screws (CC) and nuts (JJ) as shown.



CC



JJ

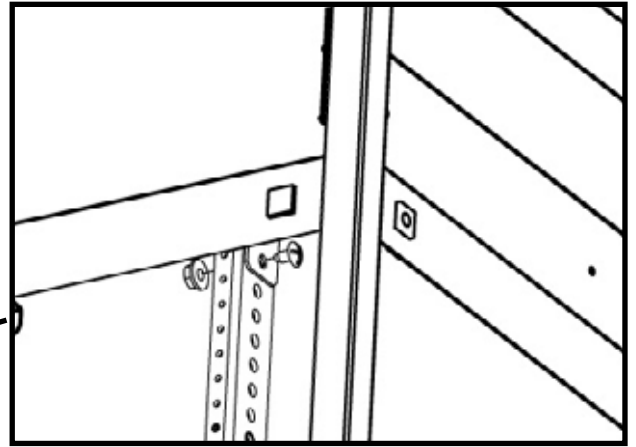
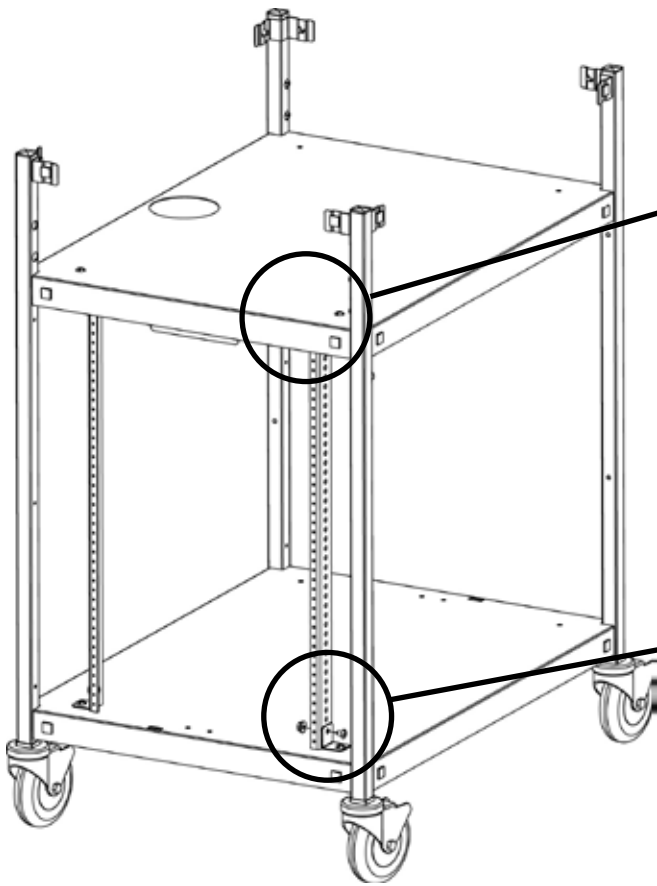

**MIDDLE SHELF ATTACHMENT**

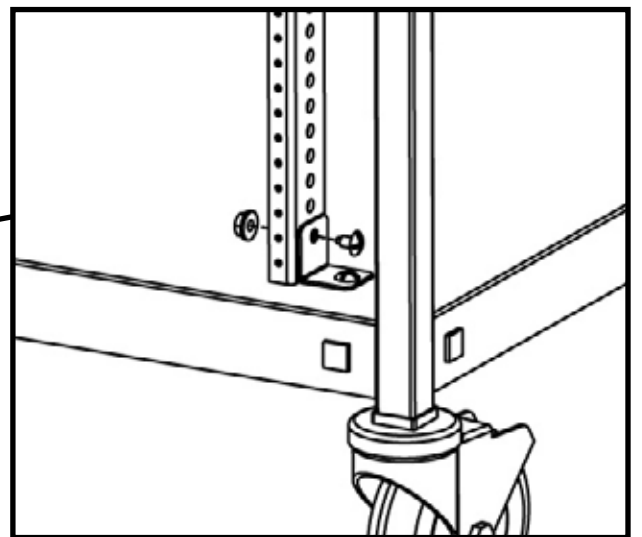

**BOTTOM SHELF ATTACHMENT**

**STEP 6**

Attach the rack rails to the L-brackets with screws (CC) and nuts (JJ) as shown. The threaded holes (smaller) are facing out.



**NOTE, THE RACK RAIL MUST BE INSTALLED AS SHOWN.**



**CORRECT**

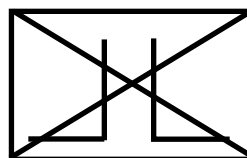

**INCORRECT**

**TOP DOWN VIEW OF INSIDE CART**

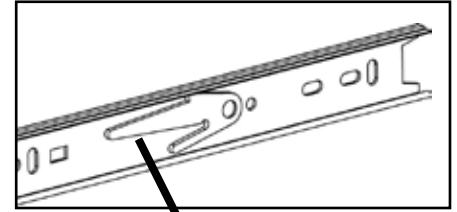
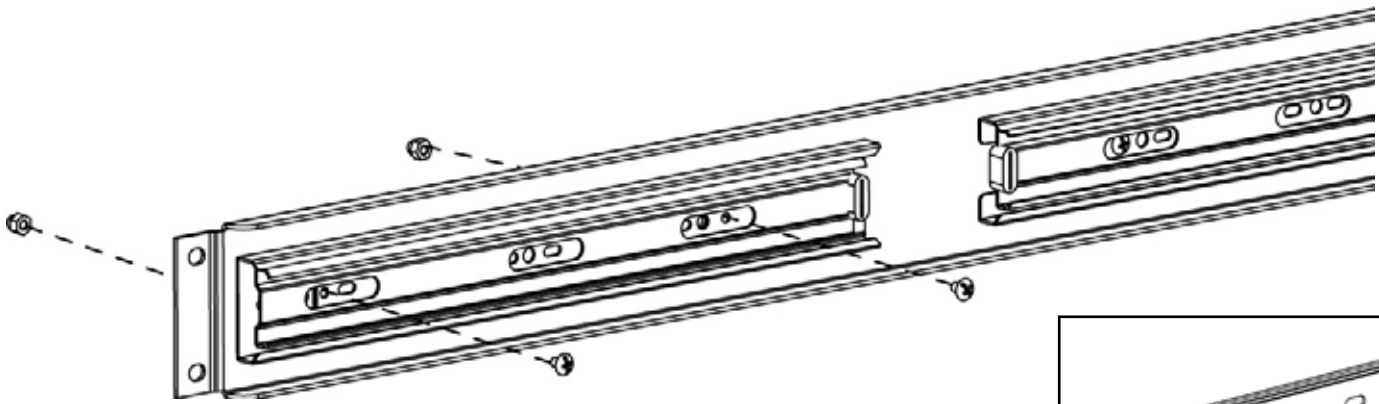

**NOTE: Separate slides by pulling on black tab.**

### STEP 7

Separate each slide and attach outer slide piece (2 per bracket) to the slide brackets using screws (EE) and nuts (FF) as shown. **NOTE:** Slide may need to be extended some to align attachment holes.



EE



FF

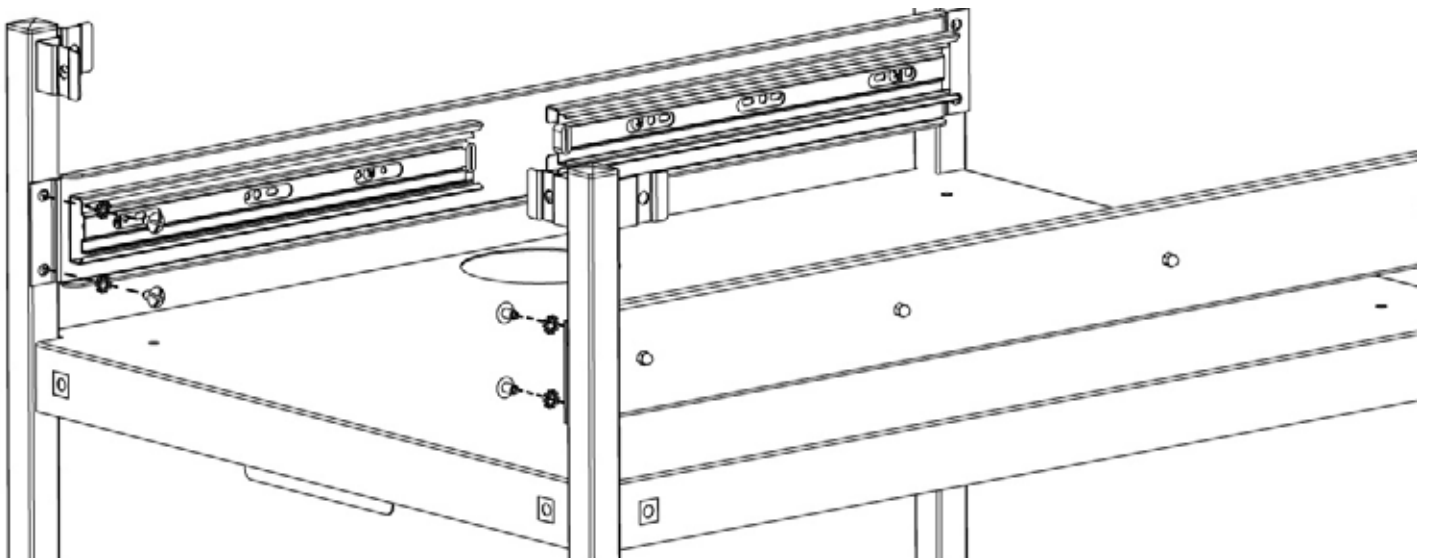

### STEP 8

Attach each slide bracket using screws (CC) and washers (DD) as shown.



CC



DD

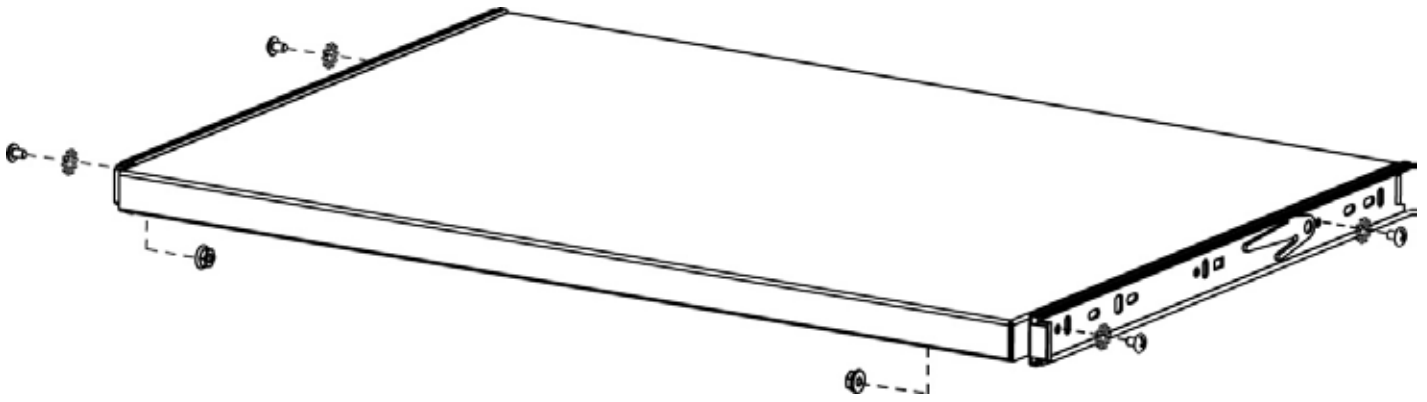

### STEP 9

Attach inner slide piece to keyboard shelf with screws (EE), washers (DD) and nuts (GG).



EE



DD



GG

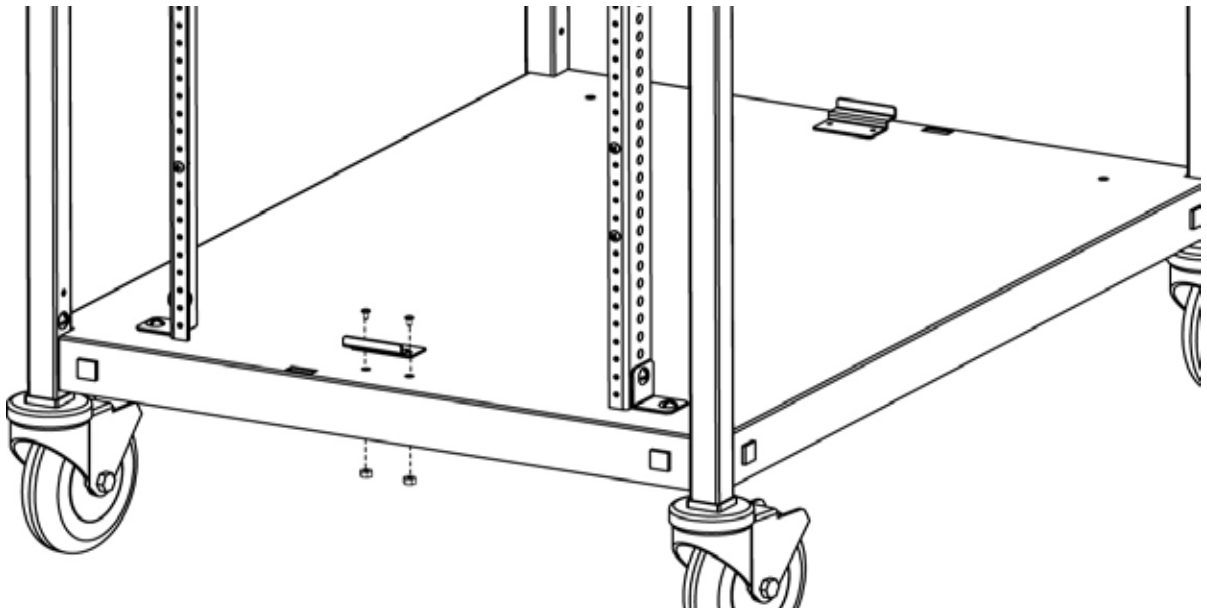

### STEP 10

Attach door stop brackets to both side of the bottom shelf with screws (HH) and nuts (II) as shown.

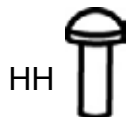

HH



II

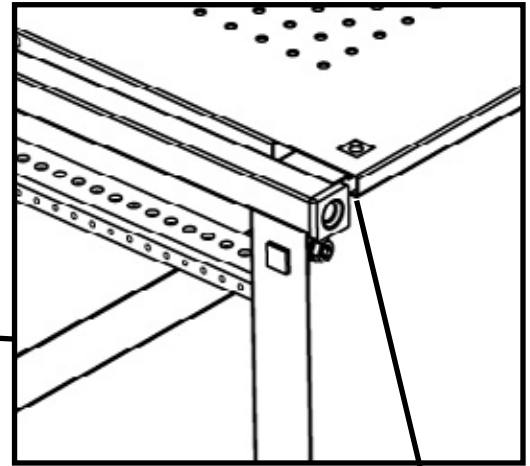
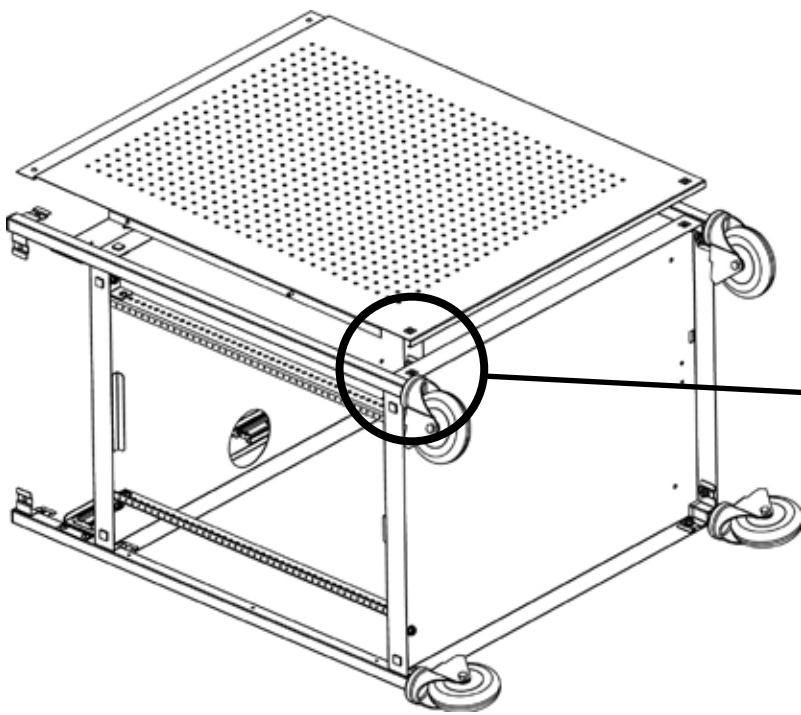

Panel bottom flange **MUST** hook onto bottom shelf

### STEP 11A

Carefully, lay cart down as shown and slide on front panel (the one without the grommet hole). **Make sure panel's bottom flange hooks onto the bottom shelf.** **NOTE:** Rear panel (the one with a grommet hole) goes on the same side of the cart as the grommet hole in the middle shelf.

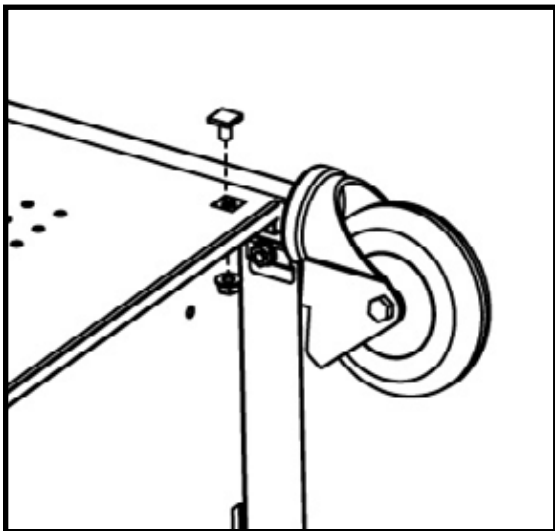

### STEP 11B

Attach side panel in each corner with bolts (AA) and nuts (BB). **HAND TIGHTEN FOR NOW.**

**ONCE THESE STEPS ARE COMPLETE REPEAT THEM FOR THE REAR PANEL.**

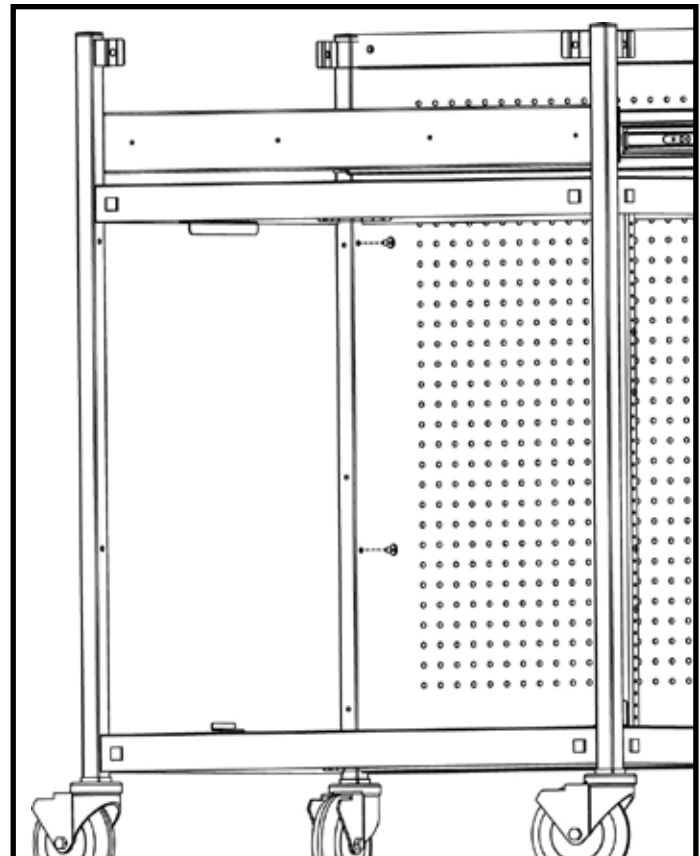

### STEP 11C

Carefully, stand cart up and then from **INSIDE** the cart, attach side panel to legs using screws (CC) as shown.



CC



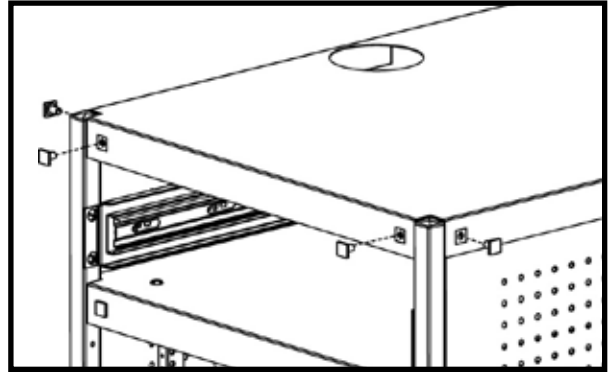
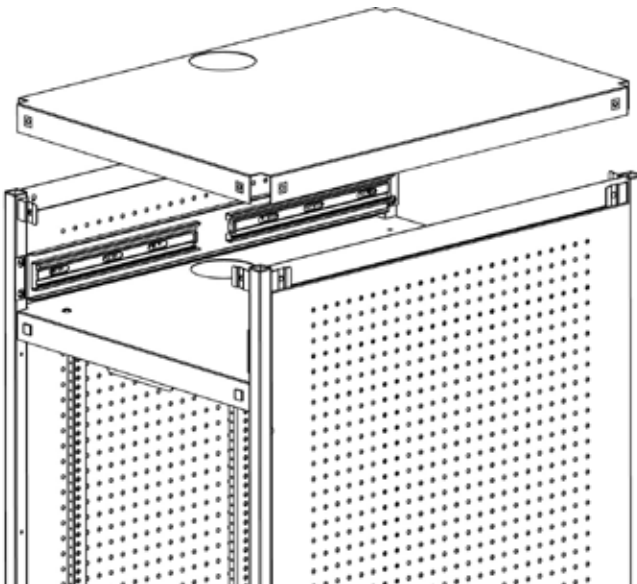

### STEP 12

Slide top shelf onto cart as shown. Secure all 4 corners with bolts (AA) and nuts (BB).

**NOW TIGHTEN ALL CORNER BOLTS AND NUTS ON THE ENTIRE CART.**

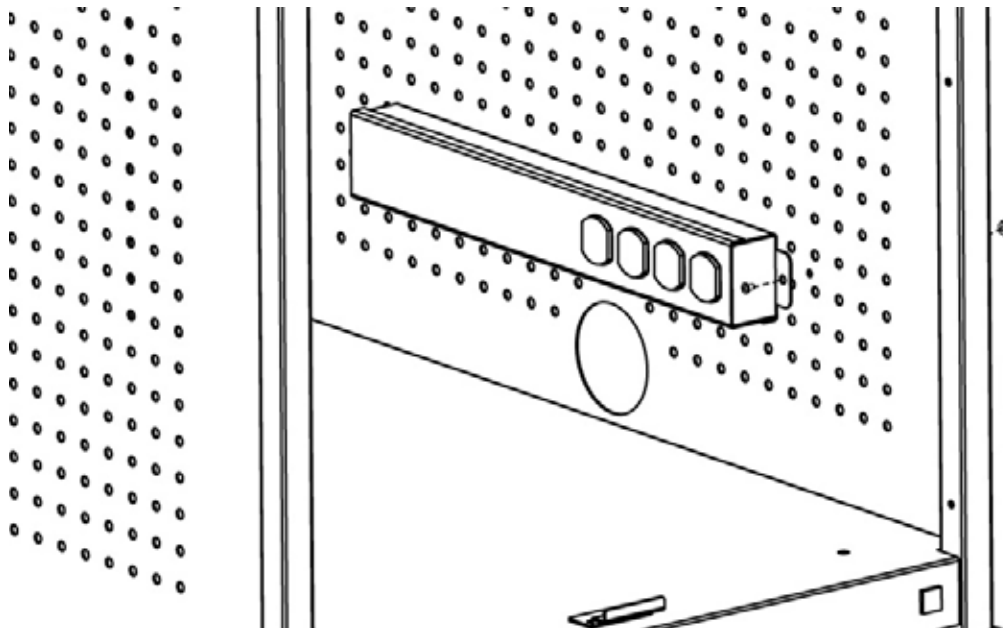

### STEP 13 - FOR TC15FF MODELS ONLY

Attach the UCSE10 unit to rear panel as shown using screws (KK) and nuts (GG).



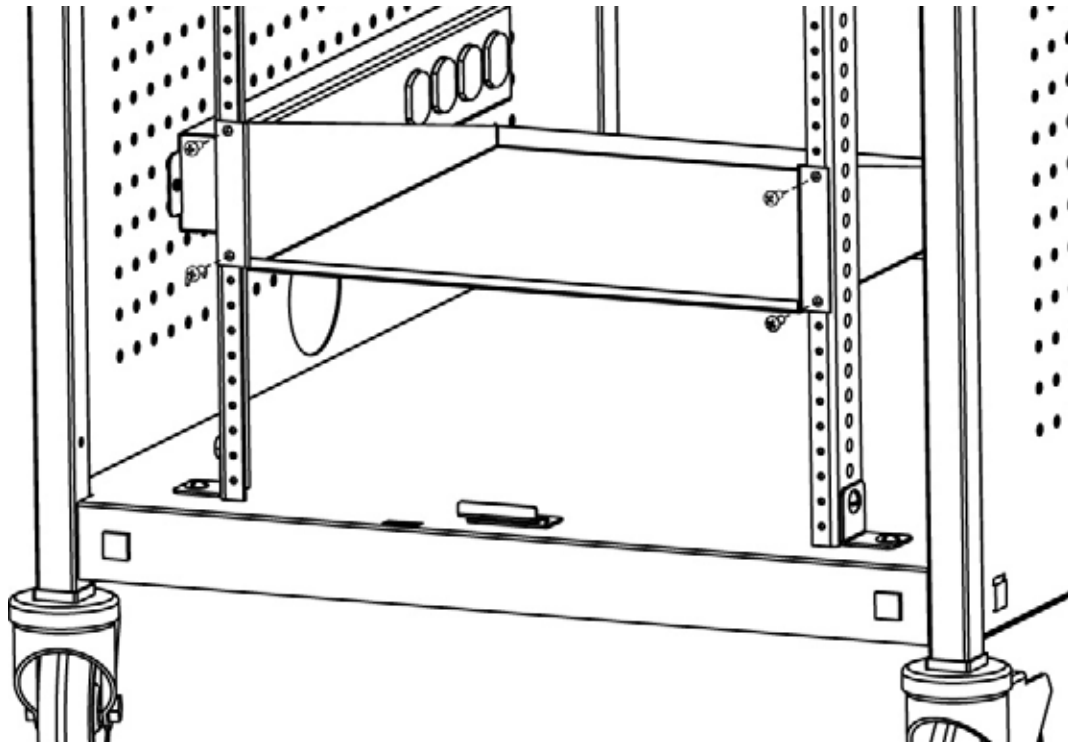

#### STEP 14

Attach the utility shelves to the rack rails as shown with screws (MM).

**NOTE:** You can install the shelves in any desired location along the rails.

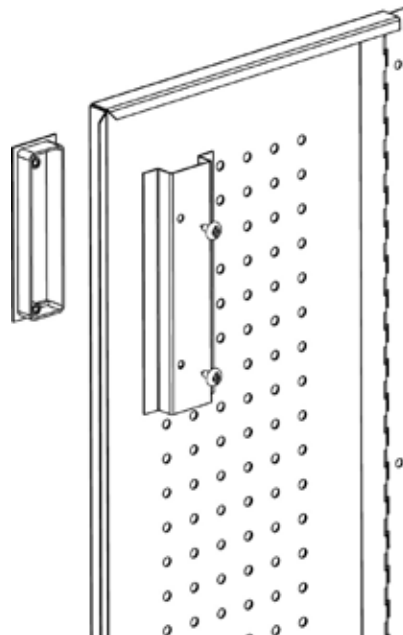

#### STEP 15

Attach a handle to each door using screws (NN) as shown.



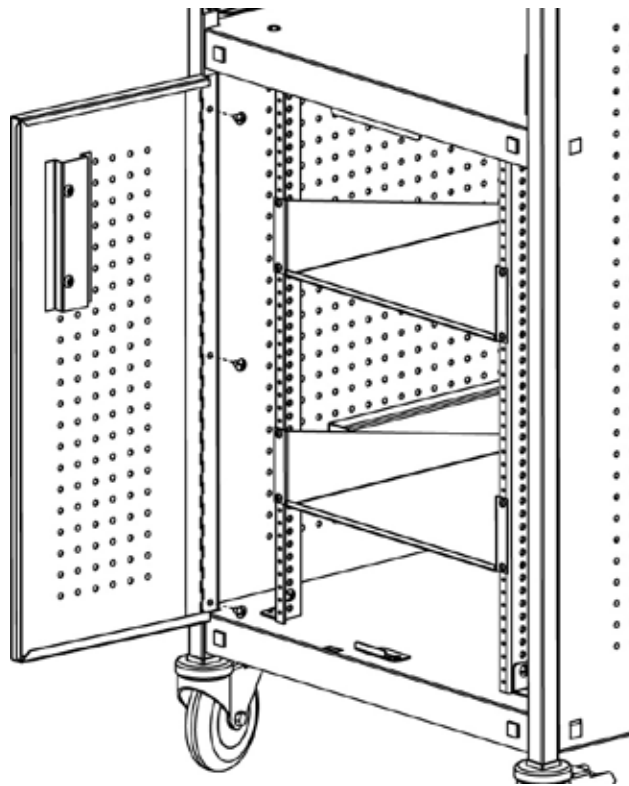

**STEP 16**

Attach the doors to each side of the cart using screws (CC) as shown.

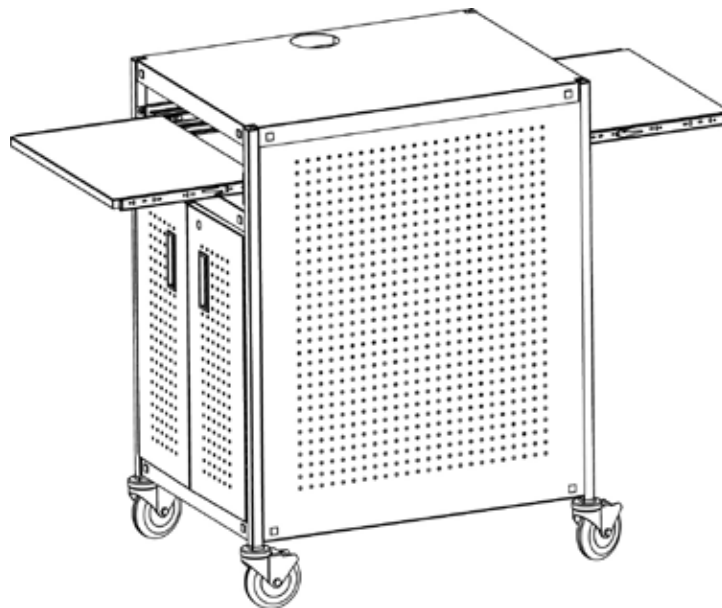

**STEP 17**

Slide both keyboard drawers into the cart.

Bretford  
 11000 Seymour Avenue  
 Franklin Park, IL 60131  
 TEL: 847.678.2545  
 800.521.9614  
 FAX: 847.678.0852  
 800.343.1779

Bretford Ltd.  
 2 Etongate  
 110 Windsor Road, Slough  
 Berkshire SL1 2JA England  
 TEL: 011 44 17 5353 9955  
 FAX: 011 44 17 5353 9478