

INSTALLATION INSTRUCTIONS

MODEL: HB-016E Custom Projector Bracket

Unpack carton and verify contents. If any listed parts are missing, immediately contact a Chief Customer Service representative by calling 1-800-582-6480.

PARTS

(1) BRACKET, Custom HB	(4) NUT, Flange, Hex, 5/16-18
(4) SCREW, Phillips Machine, M6-1.00 x 25mm	(4) FLAT WASHER, Standard Machine Screw 6mm
(4) SPACER, Nylon 1/2 OD x .316 ID x 1/2	

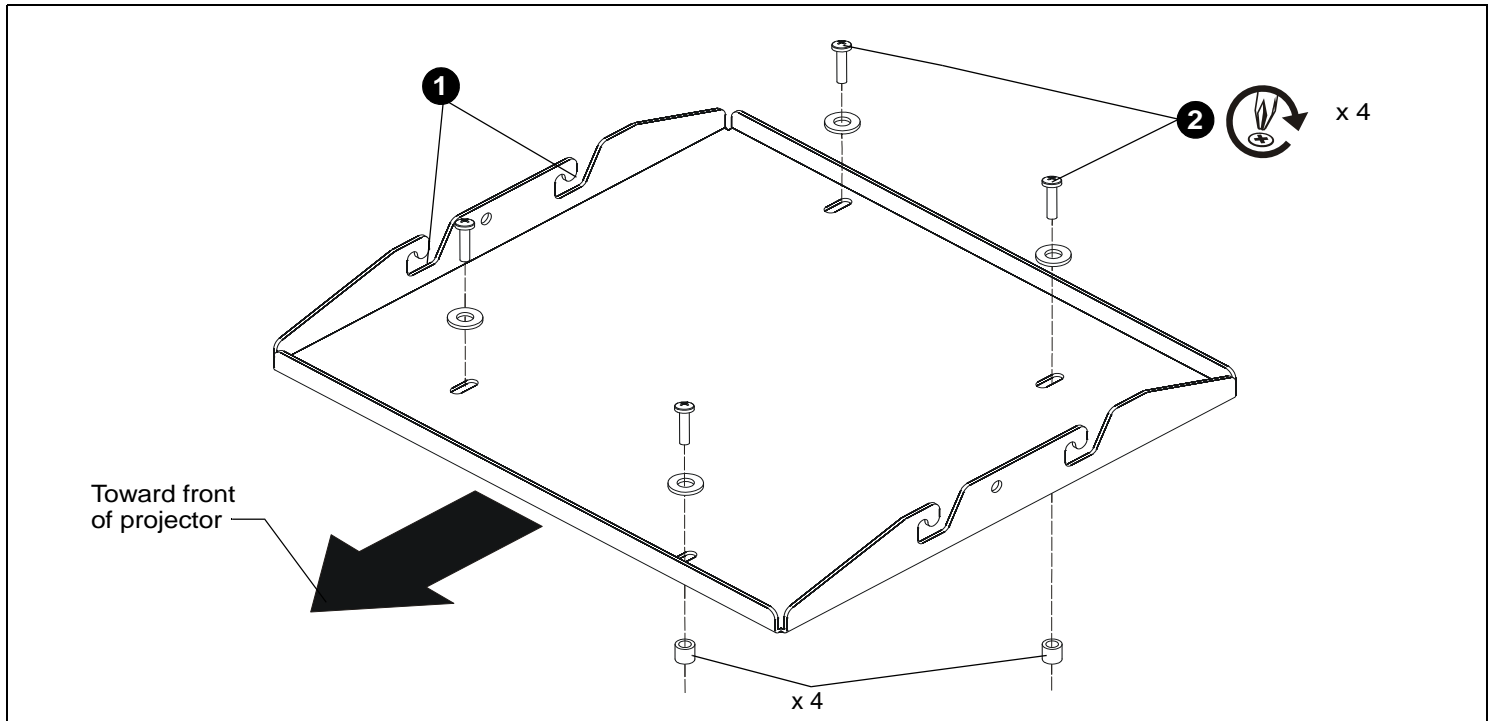

Figure 1:

INSTALLATION



WARNING: IMPROPER INSTALLATION MAY RESULT IN SERIOUS PERSONAL INJURY! All components must be securely fastened to each other and to the ceiling, and the ceiling must be capable of supporting five times the total weight of the installation.



CAUTION: This HB bracket mount is designed to support the weight of only one projector per mount. DO NOT attempt to attach more than one projector to the same mount!

1. Place custom HB bracket on underside of the projector and line up the four screw holes on the bracket with the four corresponding holes on the projector. Place four spacers in between bracket and projector holes. Ensure that the side hooks open towards back of the projector. (See Figure 1)
2. Attach HB bracket to projector using four M6-1.00 x 25mm Phillips machine screws through washers and spacers into projector. Install each screw partially to make sure all screws are aligned correctly before tightening the screws to the bracket. (See Figure 1)

Continued...

Milestone AV Technologies, and its affiliated corporations and subsidiaries (collectively, "Milestone"), intend to make this manual accurate and complete. However, Milestone makes no claim that the information contained herein covers all details, conditions or variations, nor does it provide for every possible contingency in connection with the installation or use of this product. The information contained in this document is subject to change without notice or obligation of any kind. Milestone makes no representation of warranty, expressed or implied, regarding the information contained herein. Milestone assumes no responsibility for accuracy, completeness or sufficiency of the information contained in this document.

INSTALLATION INSTRUCTIONS

Continued...

⚠ CAUTION: Installing a ceiling mount requires the presence of two persons familiar with mechanical installations. A third assistant is recommended.

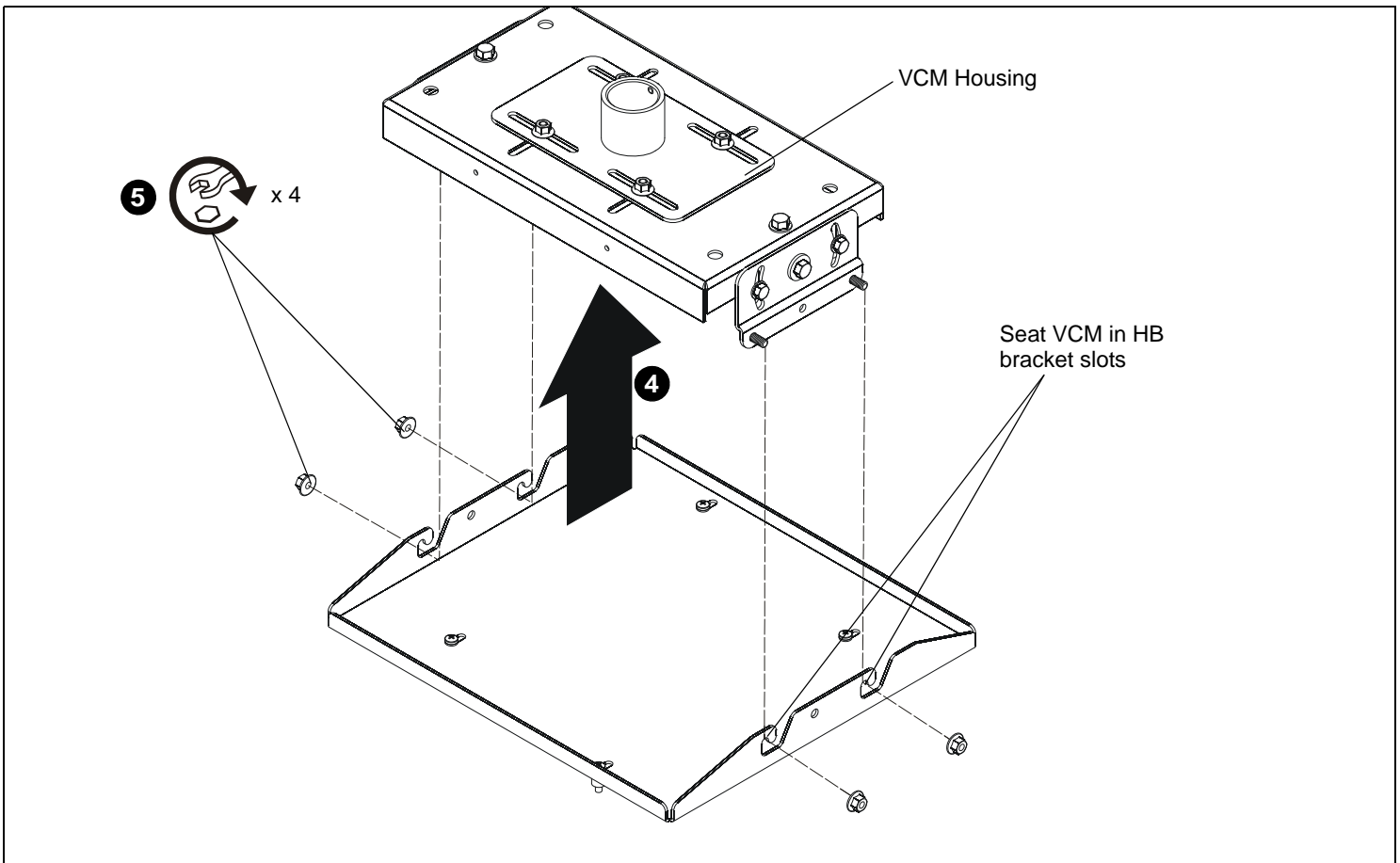

Figure 2:

3. Attach VCM housing to your method of support and tighten firmly so the VCM housing is square to the screen.
4. With help of assistants, lift the projector and install it to the four studs extending from the VCM housing. Ensure that the VCM housing is seated in slots on HB bracket. (See Figure 2)
5. Tighten the four 5/16" flange nuts. (See Figure 2)

Chief® is a registered trademark of Milestone AV Technologies. All rights reserved.