

INSTALLATION INSTRUCTIONS

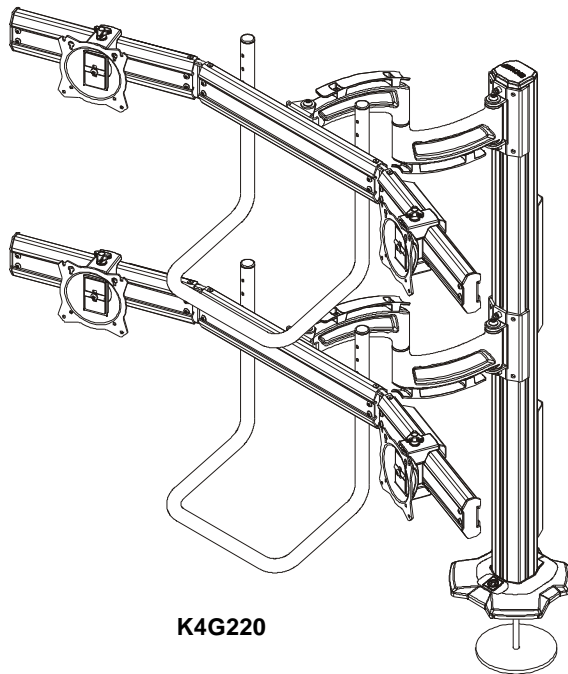

K4G220

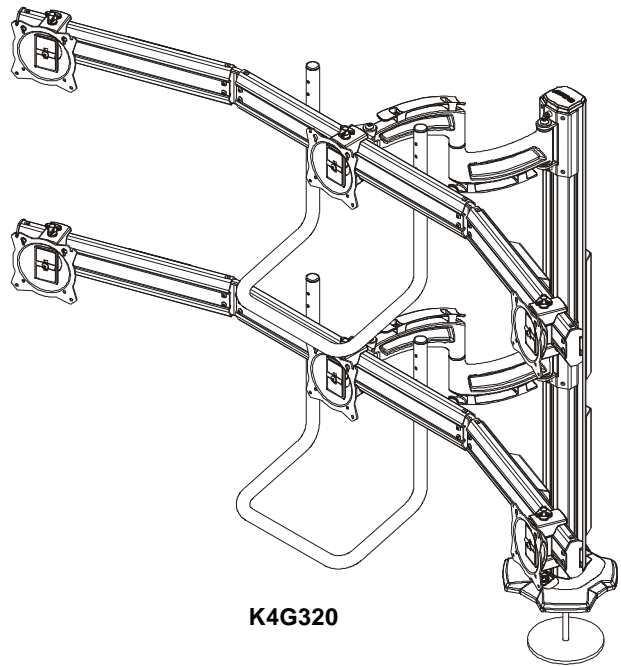

K4G320

Kontour™ Articulating Array Arm Grommet Mounts

DISCLAIMER

Milestone AV Technologies and its affiliated corporations and subsidiaries (collectively "Milestone"), intend to make this manual accurate and complete. However, Milestone makes no claim that the information contained herein covers all details, conditions or variations, nor does it provide for every possible contingency in connection with the installation or use of this product. The information contained in this document is subject to change without notice or obligation of any kind. Milestone makes no representation of warranty, expressed or implied, regarding the information contained herein. Milestone assumes no responsibility for accuracy, completeness or sufficiency of the information contained in this document.

Chief® is a registered trademark of Milestone AV Technologies. All rights reserved.



WARNING: Never operate this mounting system if it is damaged. Return the mounting system to a service center for examination and repair.



WARNING: Do not use this product outdoors.

--SAVE THESE INSTRUCTIONS--



IMPORTANT SAFETY INSTRUCTIONS



WARNING: A WARNING alerts you to the possibility of serious injury or death if you do not follow the instructions.



CAUTION: A CAUTION alerts you to the possibility of damage or destruction of equipment if you do not follow the corresponding instructions.



WARNING: Failure to read, thoroughly understand, and follow all instructions can result in serious personal injury, damage to equipment, or voiding of factory warranty! It is the installer's responsibility to make sure all components are properly assembled and installed using the instructions provided.



WARNING: Failure to provide adequate structural strength for this component can result in serious personal injury or damage to equipment! It is the installer's responsibility to make sure the structure to which this component is attached can support five times the combined weight of all equipment. Reinforce the structure as required before installing the component.



WARNING: Exceeding the weight capacity can result in serious personal injury or damage to equipment! It is the installer's responsibility to make sure the combined weight of all components located on the K4G4220-320 mounts up to (and including) the display does not exceed 15 lbs (6.8 kg) per display.



WARNING: Use this mounting system only for its intended use as described in these instructions. Do not use attachments not recommended by the manufacturer.

DIMENSIONS

K4G220

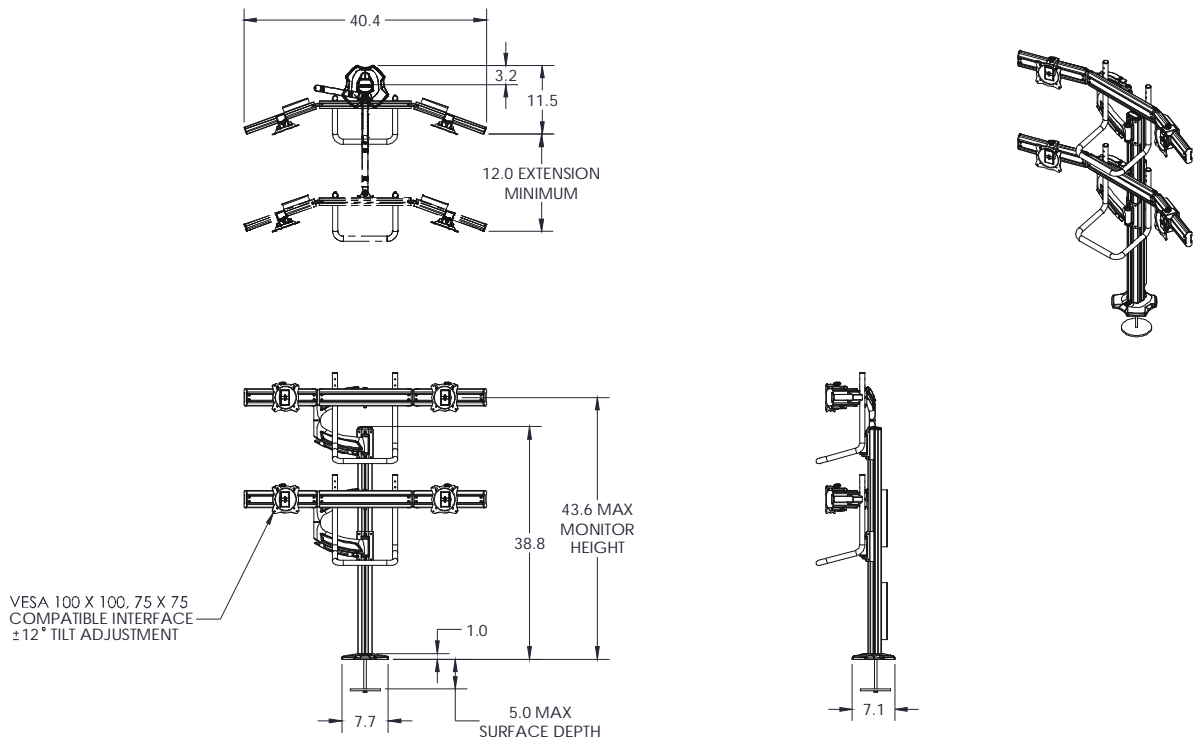

K4G320

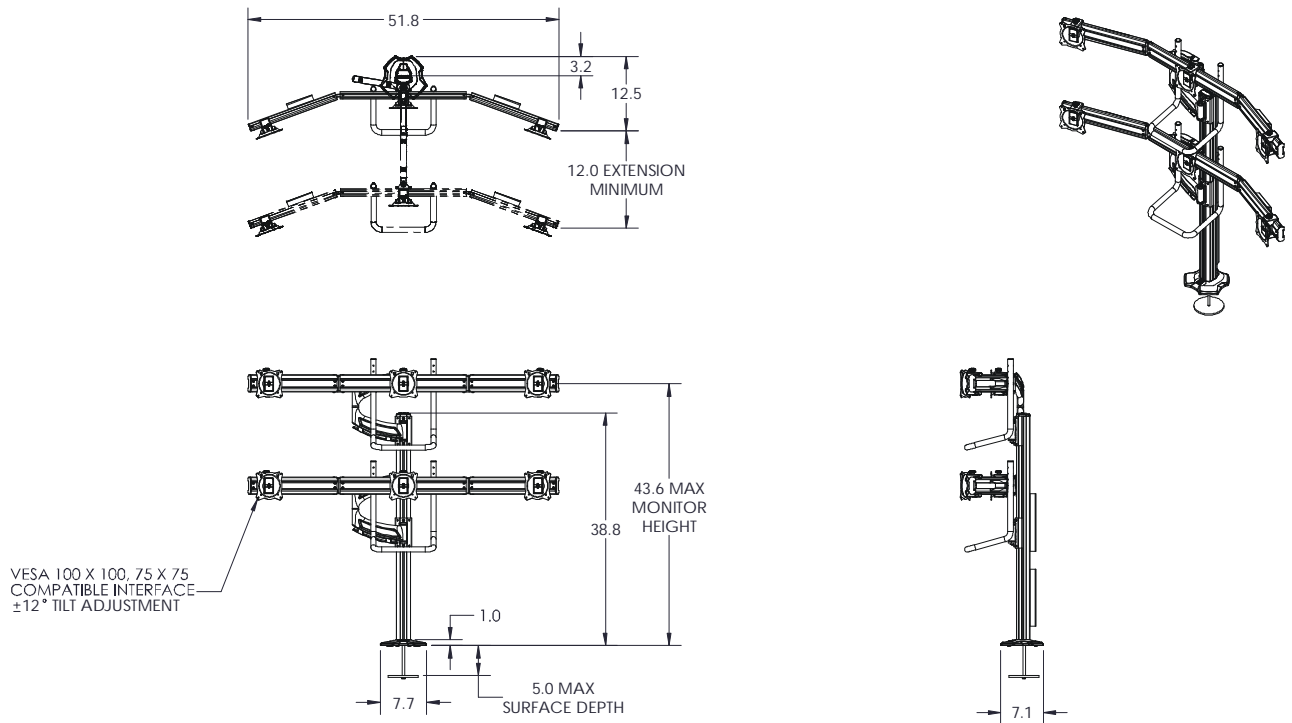

LEGEND

	Tighten Fastener Apretar elemento de fijación Befestigungsteil festziehen Apertar fixador Serrare il fissaggio Bevestiging vastdraaien Serrez les fixations		Pencil Mark Marcar con lápiz Stiftmarkierung Marcar com lápis Segno a matita Potloodmerkteken Marquage au crayon
	Loosen Fastener Aflojar elemento de fijación Befestigungsteil lösen Desapertar fixador Allentare il fissaggio Bevestiging losdraaien Desserrez les fixations		Drill Hole Perforar Bohrloch Fazer furo Praticare un foro Gat boren Percez un trou
	Phillips Screwdriver Destornillador Phillips Kreuzschlitzschraubendreher Chave de fendas Phillips Cacciavite a stella Kruiskopschroevendraaier Tournevis à pointe cruciforme		Adjust Ajustar Einstellen Ajustar Regolare Afstellen Ajuster
	Open-Ended Wrench Llave de boca Gabelschlüssel Chave de bocas Chiave a punte aperte Steeksleutel Clé à fourche		Remove Quitar Entfernen Remover Rimuovere Verwijderen Retirez
	By Hand A mano Von Hand Com a mão A mano Met de hand À la main		Optional Opcional Optional Opcional Opzionale Optie En option
	Hex-Head Wrench Llave de cabeza hexagonal Sechskantschlüssel Chave de cabeça sextavada Chiave esagonale Zeskantsleutel Clé à tête hexagonale		Security Wrench Llave de seguridad Sicherheitsschlüssel Chave de segurança Chiave di sicurezza Veiligheidsleutel Clé de sécurité

TOOLS REQUIRED FOR INSTALLATION

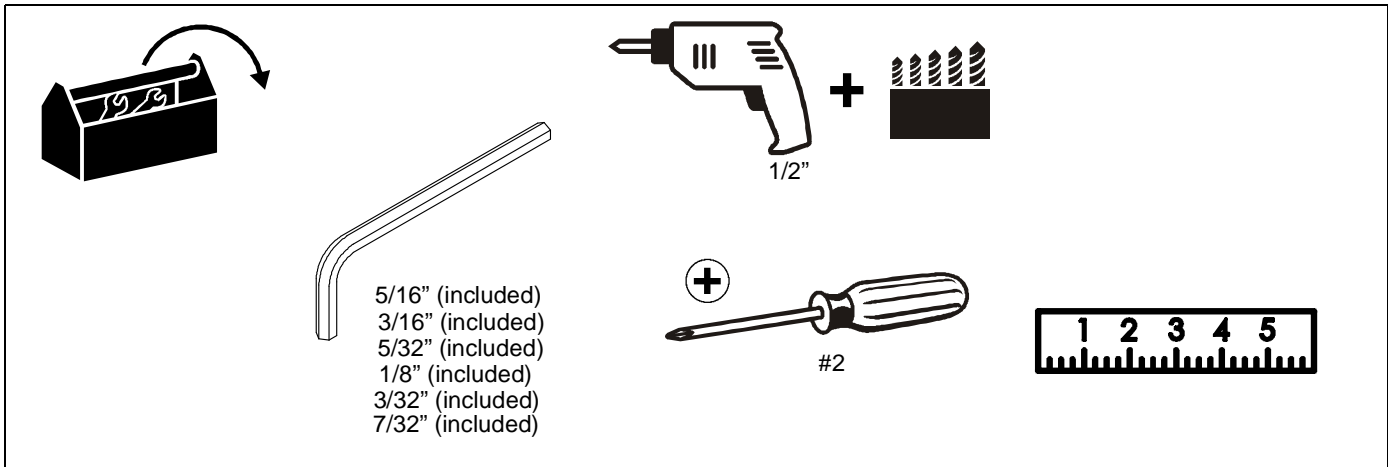

PARTS

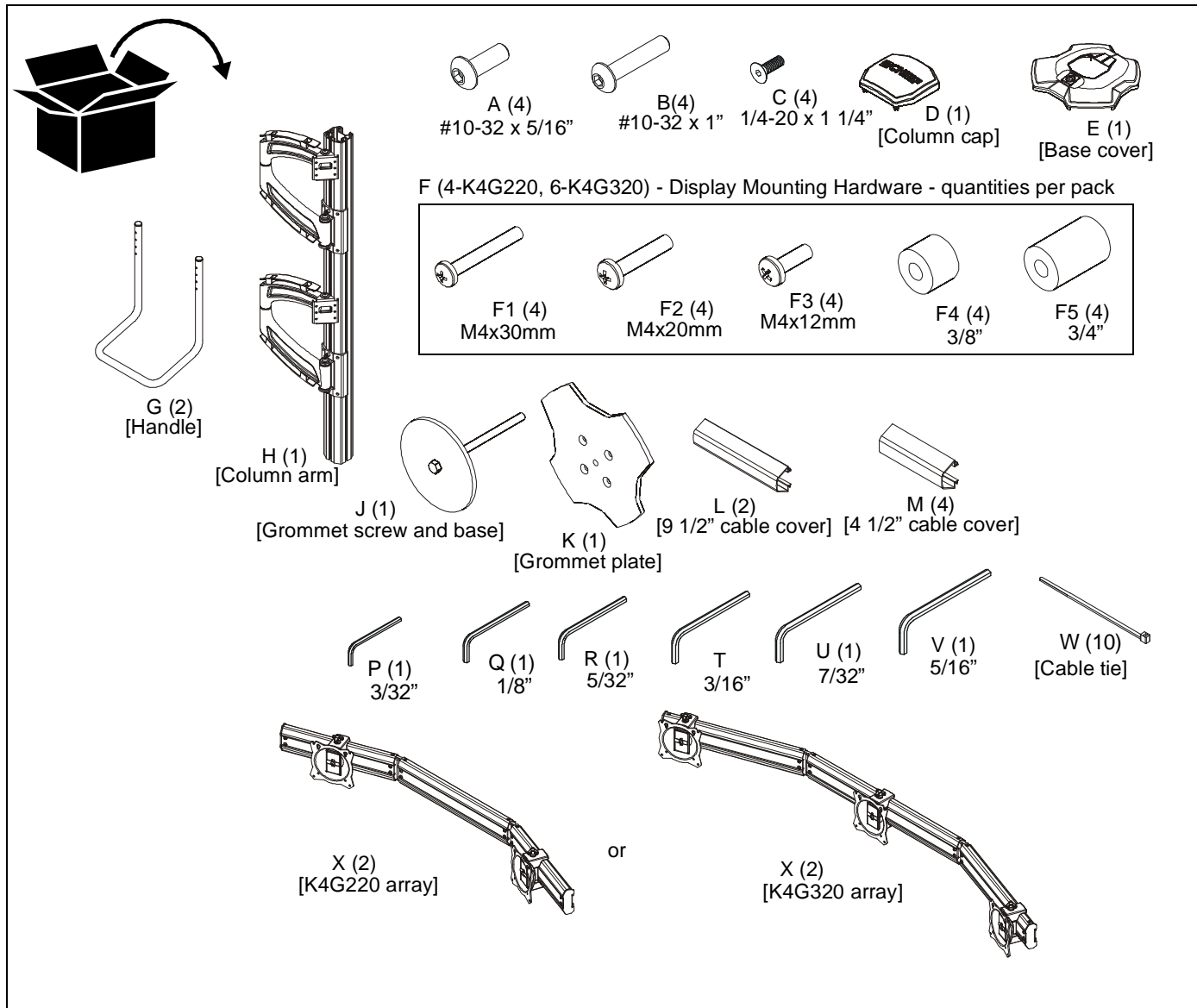

Assembly And Installation

1. Use four 1/4-20 x 1 1/4" flat head cap screws (C) to secure grommet plate (K) to column arm (H). Make sure longer legs of grommet plate are aligned with the front of column. (See Figure 1)

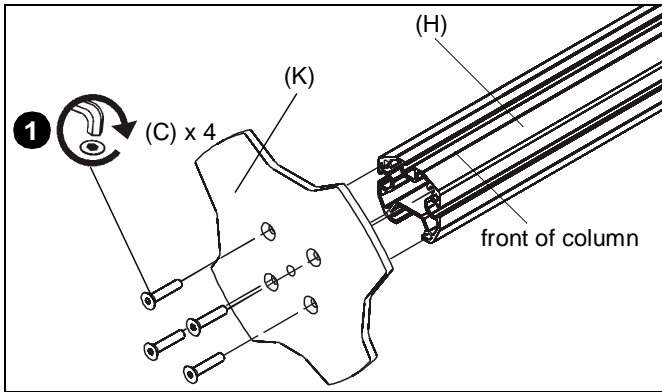

Figure 1

2. Locate a flat surface (thickness minimum of 1" to maximum of 5") on which to mount the array assembly.
3. If a hole doesn't already exist, drill a hole in desk with a diameter between 1/2" and 3" at desired mounting location. (See Figure 2)
4. Position mount on desk so that center hole of grommet plate (K) is centered over grommet hole. (See Figure 2)
5. Insert grommet screw (J) through grommet hole and thread into center hole of grommet plate (K). (See Figure 2)
6. Tighten grommet screw (J) until grommet base is tightened against underside of desk and mount is securely mounted to desk. (See Figure 2)

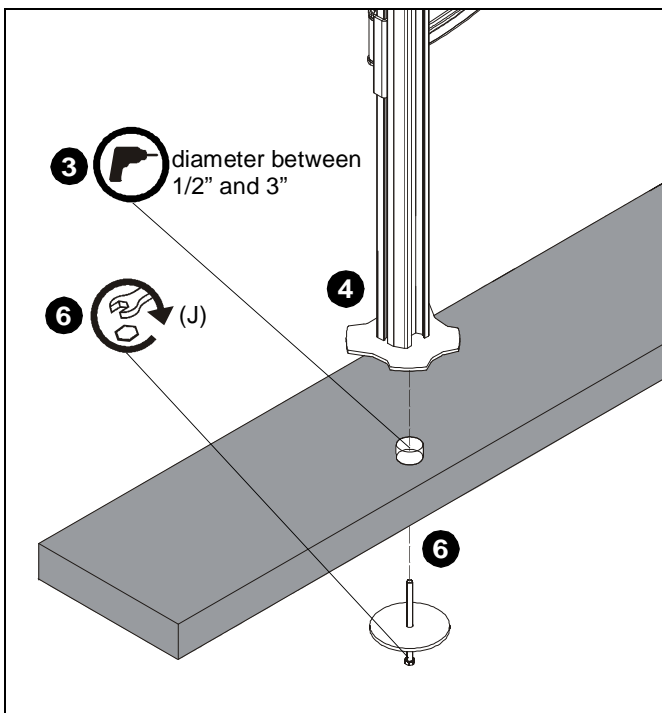

Figure 2

7. Carefully manipulate base cover (E) to create an opening large enough to wrap cover around array column. (See Figure 3)
8. Wrap base cover (E) around column and slide it down until base cover fits securely onto grommet plate (K). (See Figure 3)

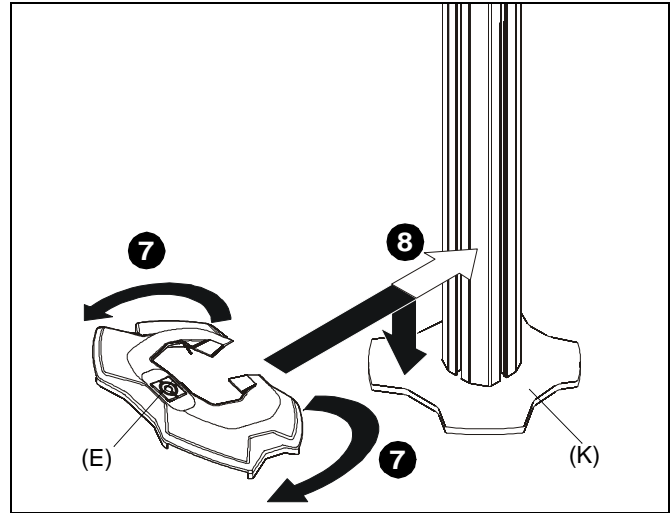

Figure 3

9. Tighten two socket head cap screws to secure each column arm at desired height. (See Figure 4)
10. Install column cap (D) to column (H). (See Figure 4)

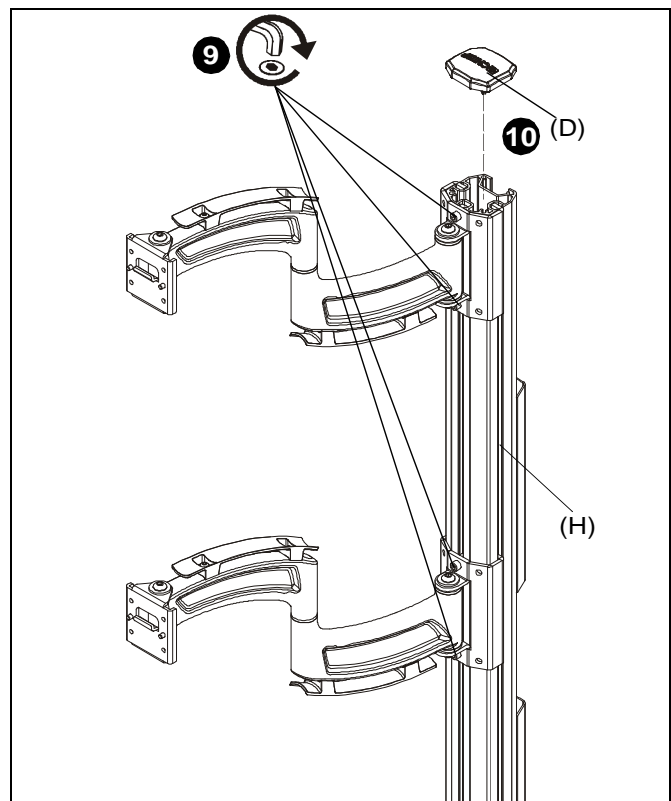

Figure 4

11. Hang two array arms (X) onto column arm faceplates using the mounting tab on the faceplates. (See Figure 5)

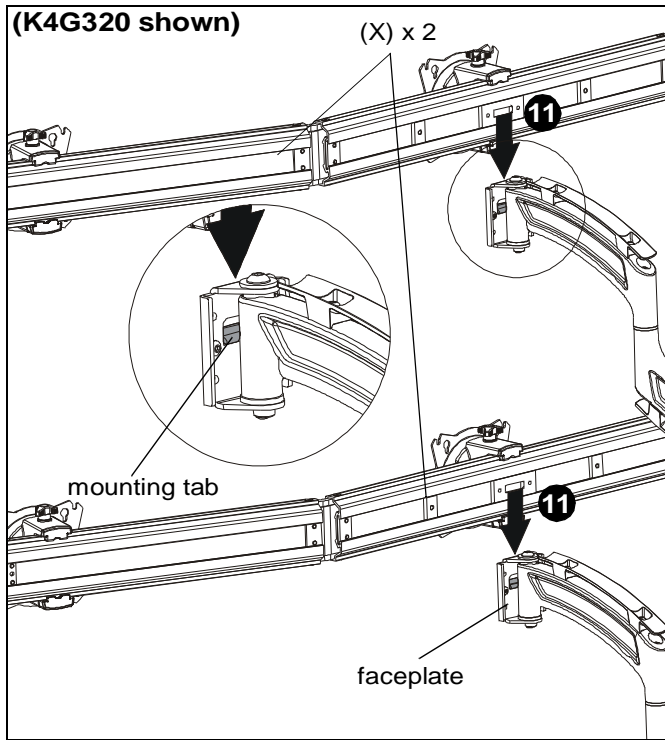

Figure 5

12. Use four #10-32 x 5/16" button head cap screws (A) to secure each column arm to arrays (X). (See Figure 6)

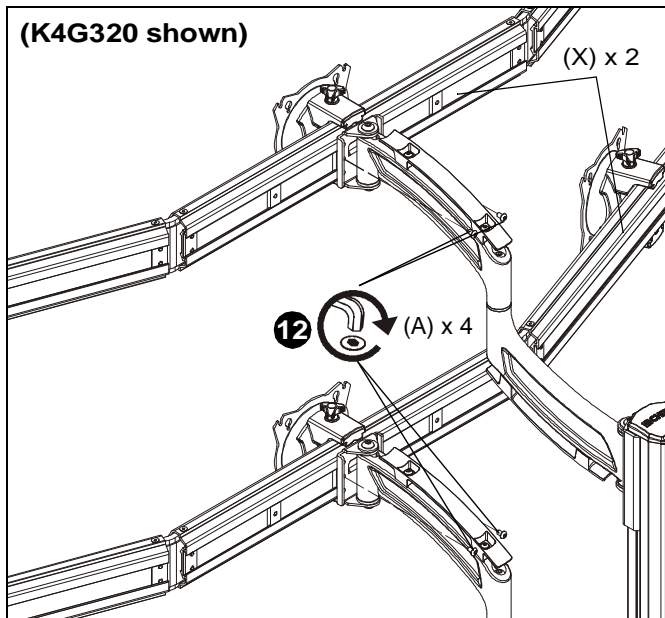

Figure 6

13. Use four #10-32 x 1" button head cap screws (B) to secure two handles (G) to array arms (X). (See Figure 7)

NOTE: Keep in mind the size of the display when selecting which holes to use to attach the handles.

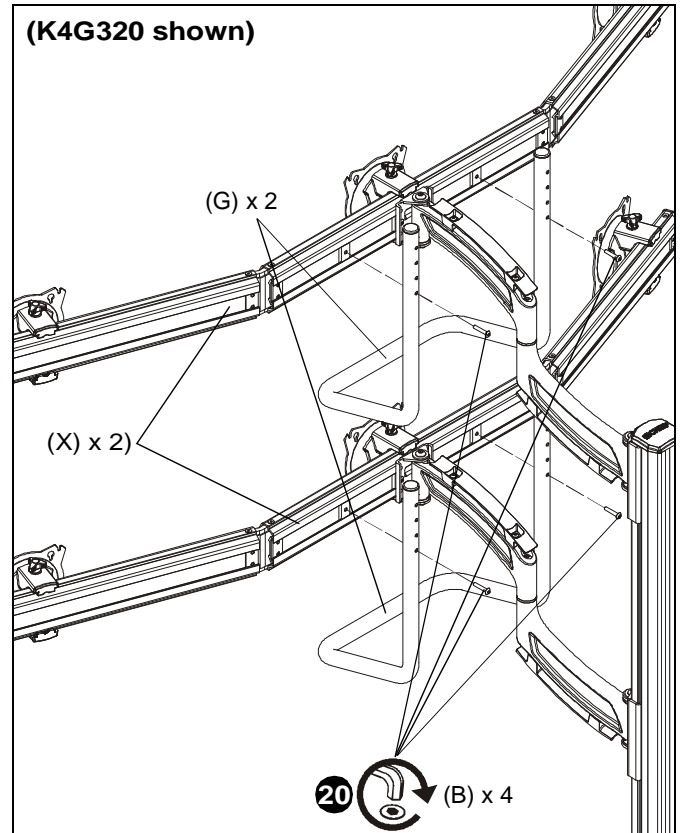

Figure 7

Display Installation



WARNING: Exceeding the weight capacity can result in serious personal injury or damage to equipment! It is the installer's responsibility to make sure the combined weight of all components located on the K4G220-320 mounts up to (and including) the display does not exceed 15 lbs (6.8 kg) per display.



CAUTION: Using screws of improper size may damage your display! Proper screws will easily thread into display mounting holes.

NOTE: Supplied screws (F1, F2 and F3) may not fit properly for all displays. See display's operating instructions for details.

Flush Mounting Holes

1. Position faceplate in desired mounting position. Adjust as required before proceeding. See Height Adjustment Section for details.
2. Using Phillips screwdriver, carefully install two M4 x 12mm Phillips pan machine screws (F3) into the *upper* mounting holes on the display. Thread screws completely into display, then back out 3 complete turns. (See Figure 8)

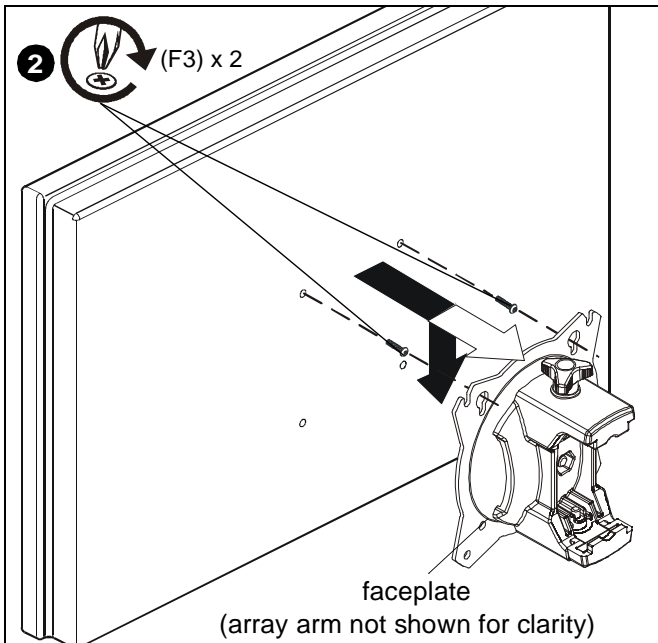

Figure 8

3. Pick up and align display so that screws (F3) (installed on the back of the display in the previous step) fit into the mounting holes on the faceplate. Lower the display firmly into place. (See Figure 8)
4. Using Phillips screwdriver, install two M4x12 mm Phillips pan machine screws (F3) through the *lower* mounting holes on faceplate into the display. (See Figure 9)

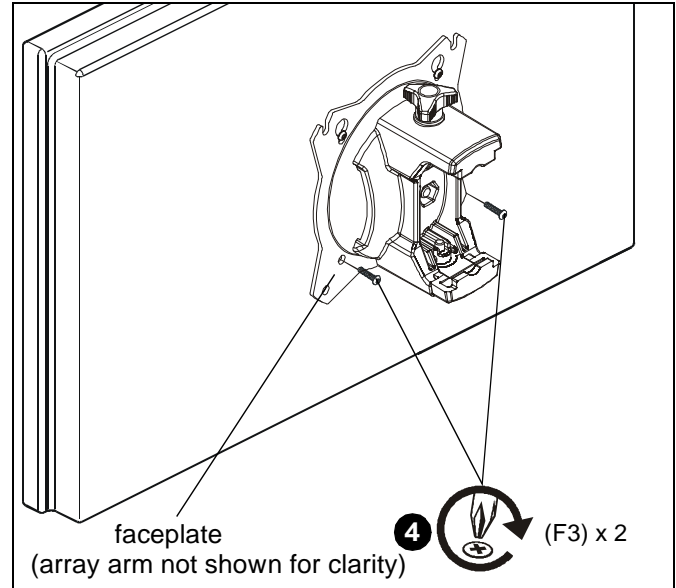

Figure 9

5. Tighten all four screws (F3). Do not over-tighten!

NOTE: If roll adjustment is desired for center faceplate, do not tighten screws.

6. Repeat Steps 1-5 for other displays.
7. Proceed to Cable Management Section.

Recessed Mounting Holes

NOTE: If faceplate does not fit into recessed area of display, proceed with the steps in this section.

1. Determine depth of recessed mounting holes relative to back surface of display (against which faceplate will contact).
2. Select proper length spacer and screw from table below:

NOTE: All spacers used should be the same length. If the recess depths result in multiple spacer lengths, then select the longer spacer.

IF recess DEPTH is:	THEN use spacer:	AND screw:
3/8" or less	F4 (3/8" long)	F2 (M4 x 20mm)
More than 3/8" up to and including 3/4"	F5 (3/4" long)	F1 (M4 x 30mm)



CAUTION: Using screws of improper size may damage your display! Proper screws will easily and completely thread into display mounting holes.

3. Using Phillips screwdriver, carefully install two selected screws (F1 or F2) through selected spacers (F4 or F5) into the *upper* mounting holes on the display. Thread screws completely into display, then back out 3 complete turns. (See Figure 10)
4. Pick up and align display so that screws (F1 or F2) (installed on the back of the display in the previous step) fit into the mounting holes on the faceplate. Lower the display firmly into place. (See Figure 10)

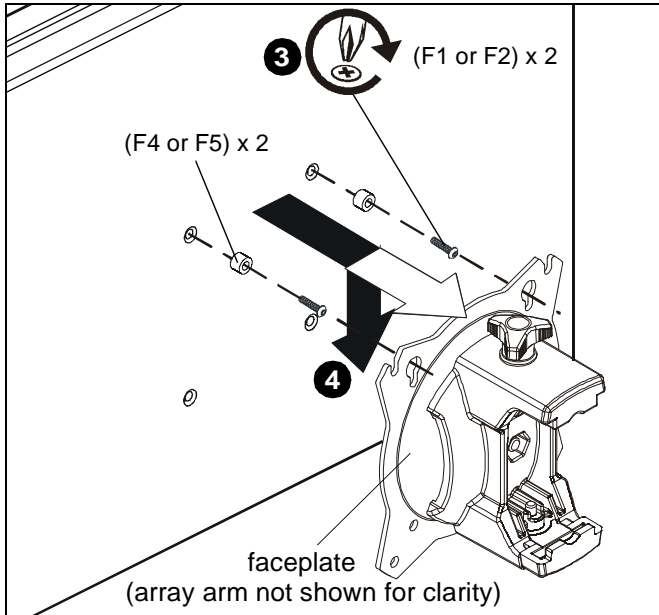

Figure 10

5. Slide two remaining selected spacers (F4 or F5) in between faceplate and display, positioning them over the *lower* two mounting holes. (See Figure 11)
6. Install two remaining selected screws (F1 or F2) through *lower* two mounting holes on faceplate, selected spacers (F4 or F5) into the *lower* mounting holes on the display. (See Figure 11)

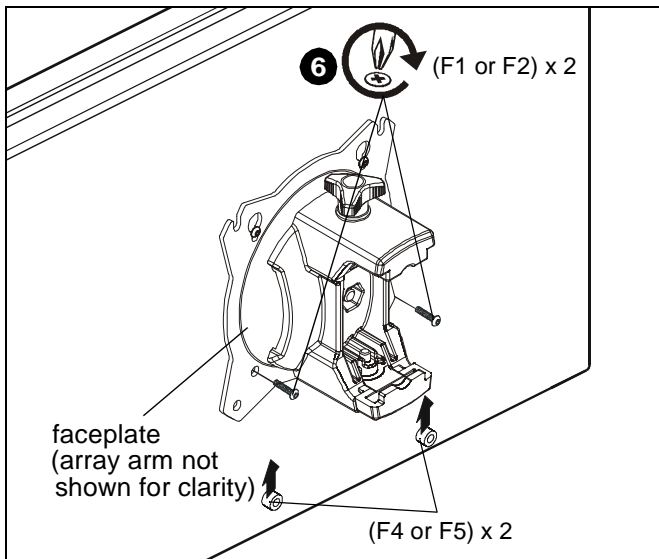

Figure 11

7. Tighten all four screws. Do not over-tighten!

Adjustments

Pivot Adjustment (Column Arm)

1. Use handles (G) to extend or collapse column arms as desired. (See Figure 12)
2. (Optional) Loosen or tighten column arm pivot tension screws as desired to increase or decrease pivot tension. (See Figure 12)

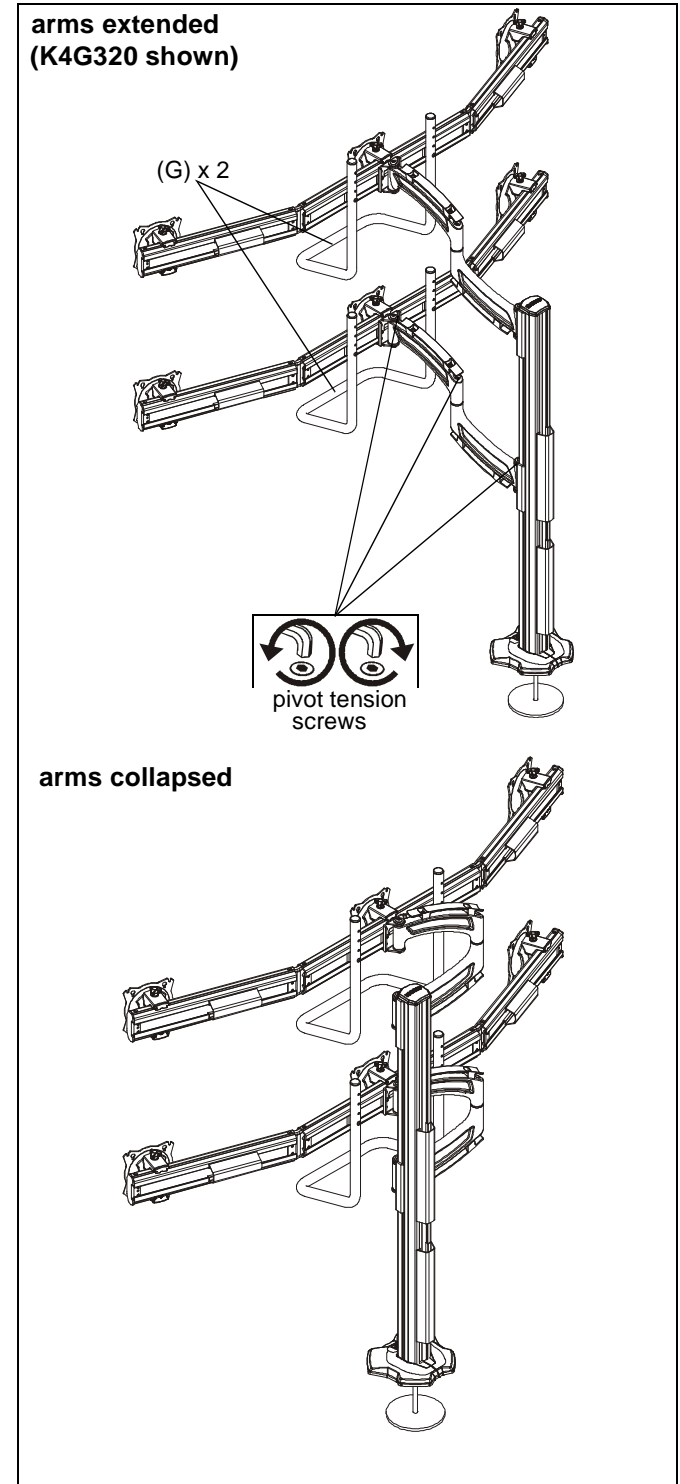

Figure 12

Height Adjustment

1. Loosen socket head cap screws holding column arm to column. (See Figure 13)
2. Adjust column arm to desired height. (See Figure 13)
3. Tighten socket head cap screws to lock column arm's position. (See Figure 13)

NOTE: The height on both columns should be adjusted simultaneously to ensure a level mount.

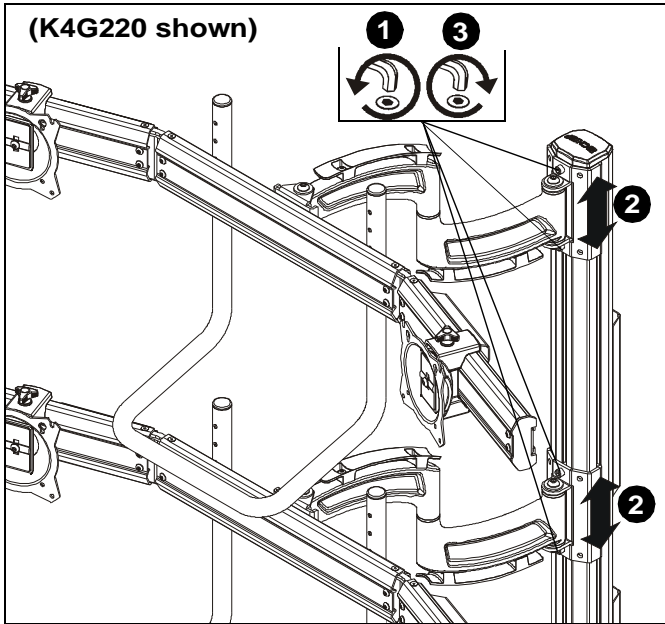

Figure 13

Faceplate Assembly Removal

1. Remove socket head cap screw from bottom of faceplate assembly. (See Figure 14)
2. Slide out removable plate from bottom of faceplate assembly. (See Figure 14)

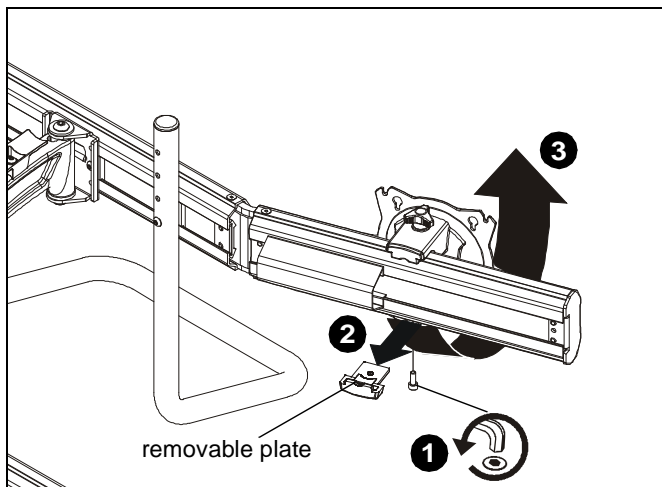

Figure 14

3. Remove faceplate assembly from array arm. (See Figure 14)

To Reattach Faceplate Assembly

4. Place faceplate assembly on array arm at desired mounting position. (See Figure 15)
5. Slide removable plate back into slot at bottom of faceplate assembly. (See Figure 15)
6. Reinstall socket head cap screw removed in Step 1 to secure faceplate assembly to array arm. (See Figure 15)

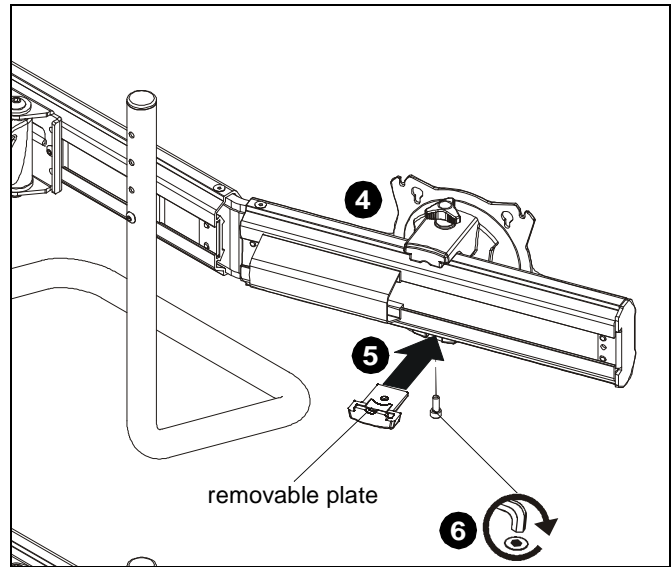

Figure 15

Lateral Shift

1. Loosen knob on top of faceplate assembly until faceplate can slide freely along array. (See Figure 16)
2. Adjust lateral position as desired. (See Figure 16)
3. Tighten knob to secure lateral position. (See Figure 16)

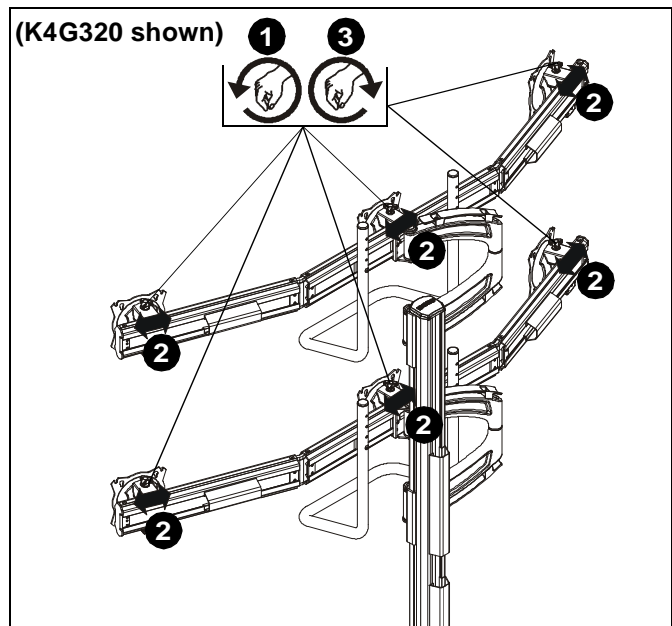

Figure 16

Pitch/Roll/Yaw Adjustment

1. Loosen knob on top of faceplate assembly. (See Figure 17)
2. Adjust pitch, roll and/or yaw as desired. (See Figure 17)
3. Tighten knob to secure desired faceplate position. (See Figure 17)

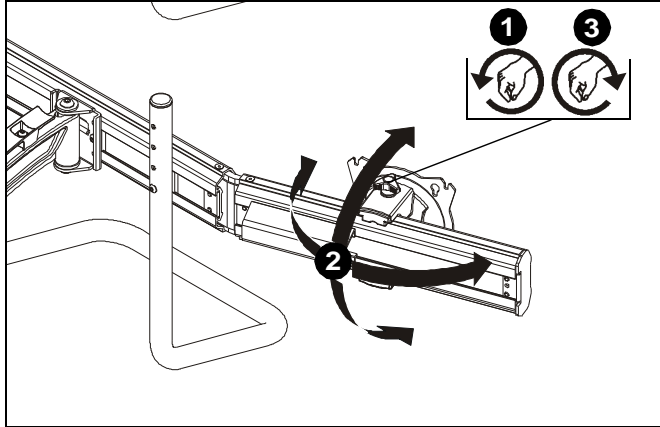

Figure 17

Cable Management

1. Install four 4 1/2" cable covers (M) to array arms. (See Figure 18)
2. Install two 9 1/2" cable covers (L) to column (H). (See Figure 18)

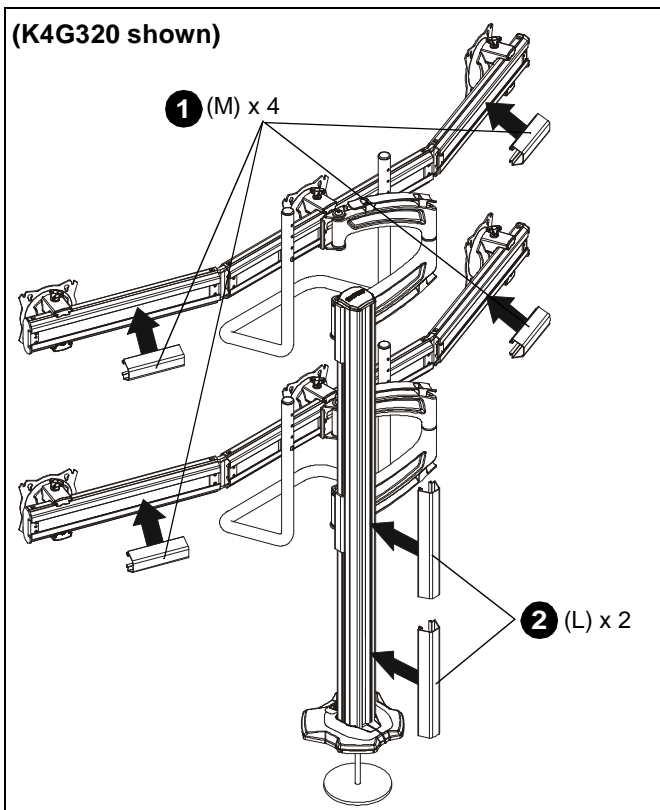

Figure 18

3. Route cables from display through cable management covers (M) on array arms as desired. (See Figure 19)
4. Route cables along swing arms, using cable ties (W) to secure cables to arms. (See Figure 19)
5. Route cables through cable management covers on columns (L) as desired. (See Figure 19)

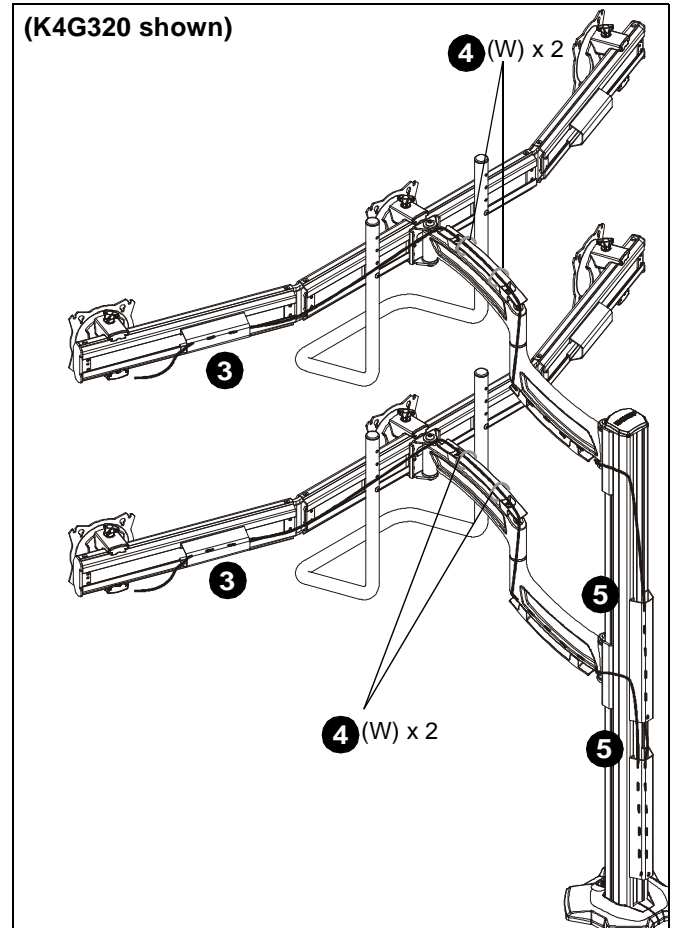

Figure 19



Our Mounts. **Your Vision.**

Chief, a products division of
Milestone AV Technologies

8800-002431 Rev00
©2014 Milestone AV Technologies
www.chiefmfg.com
04/14

USA/International	A 6436 City West Parkway, Eden Prairie, MN 55344 P 800.582.6480 / 952.225.6000 F 877.894.6918 / 952.894.6918
Europe	A Franklinstraat 14, 6003 DK Weert, Netherlands P +31 (0) 495 580 852 F +31 (0) 495 580 845
Asia Pacific	A Office No. 1 on 12/F, Shatin Galleria 18-24 Shan Mei Street Fotan, Shatin, Hong Kong P 852 2145 4099 F 852 2145 4477

