

---

# INSTALLATION INSTRUCTIONS

---

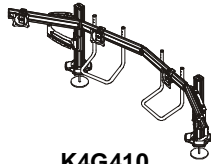

**K4G410**

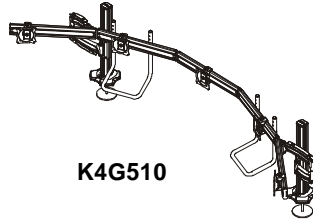

**K4G510**

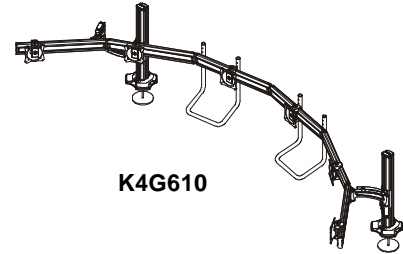

**K4G610**

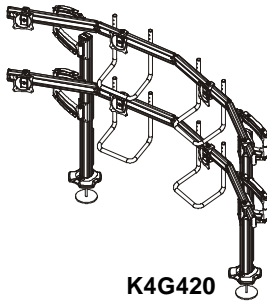

**K4G420**

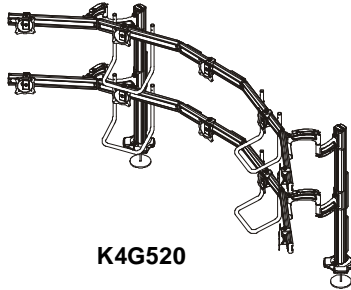

**K4G520**

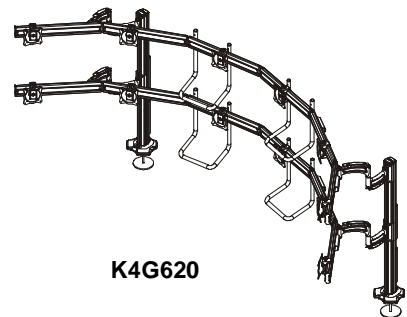

**K4G620**

---

## Large Kontour™ Articulating Array Arm Grommet Series

---

## DISCLAIMER

Milestone AV Technologies and its affiliated corporations and subsidiaries (collectively "Milestone"), intend to make this manual accurate and complete. However, Milestone makes no claim that the information contained herein covers all details, conditions or variations, nor does it provide for every possible contingency in connection with the installation or use of this product. The information contained in this document is subject to change without notice or obligation of any kind. Milestone makes no representation of warranty, expressed or implied, regarding the information contained herein. Milestone assumes no responsibility for accuracy, completeness or sufficiency of the information contained in this document.

Chief® is a registered trademark of Milestone AV Technologies. All rights reserved.



**WARNING:** Use this mounting system only for its intended use as described in these instructions. Do not use attachments not recommended by the manufacturer.



**WARNING:** Never operate this mounting system if it is damaged. Return the mounting system to a service center for examination and repair.



**WARNING:** Do not use this product outdoors.

**--SAVE THESE INSTRUCTIONS--**



## IMPORTANT SAFETY INSTRUCTIONS



**WARNING:** A WARNING alerts you to the possibility of serious injury or death if you do not follow the instructions.



**CAUTION:** A CAUTION alerts you to the possibility of damage or destruction of equipment if you do not follow the corresponding instructions.



**WARNING:** Failure to read, thoroughly understand, and follow all instructions can result in serious personal injury, damage to equipment, or voiding of factory warranty! It is the installer's responsibility to make sure all components are properly assembled and installed using the instructions provided.



**WARNING:** Failure to provide adequate structural strength for this component can result in serious personal injury or damage to equipment! It is the installer's responsibility to make sure the structure to which this component is attached can support five times the combined weight of all equipment. Reinforce the structure as required before installing the component.



**WARNING:** Exceeding the weight capacity can result in serious personal injury or damage to equipment! It is the installer's responsibility to make sure the combined weight of all components located on the K4G4X-5X-6X Series mounts up to (and including) the display does not exceed 15 lbs (6.8 kg) per display.



**WARNING:** The K4G4X-5X-6X Series mounts were designed to mount displays between 19-23" in width. Do NOT install displays smaller than 19" in width or larger than 23" in width!

**DIMENSIONS**

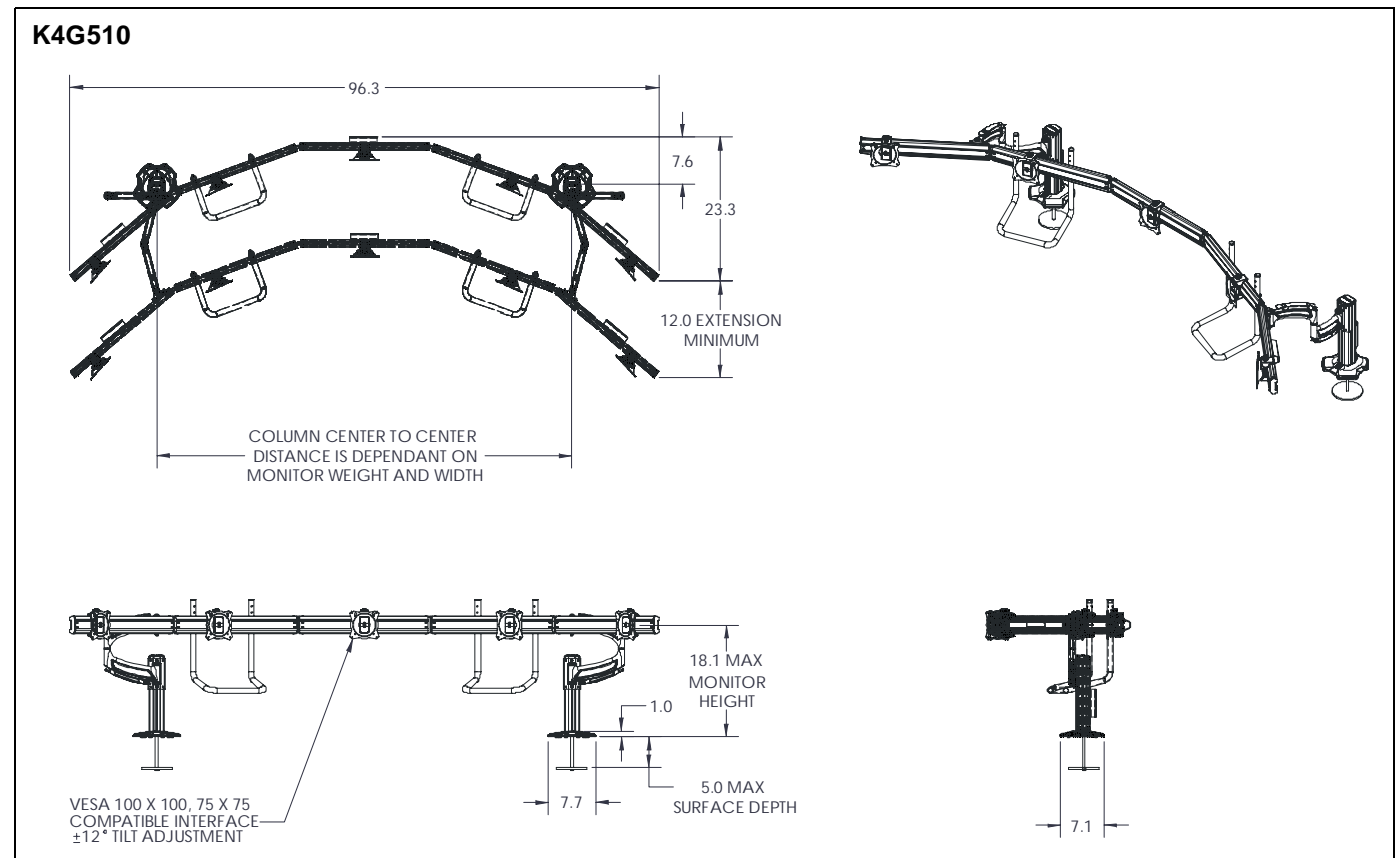
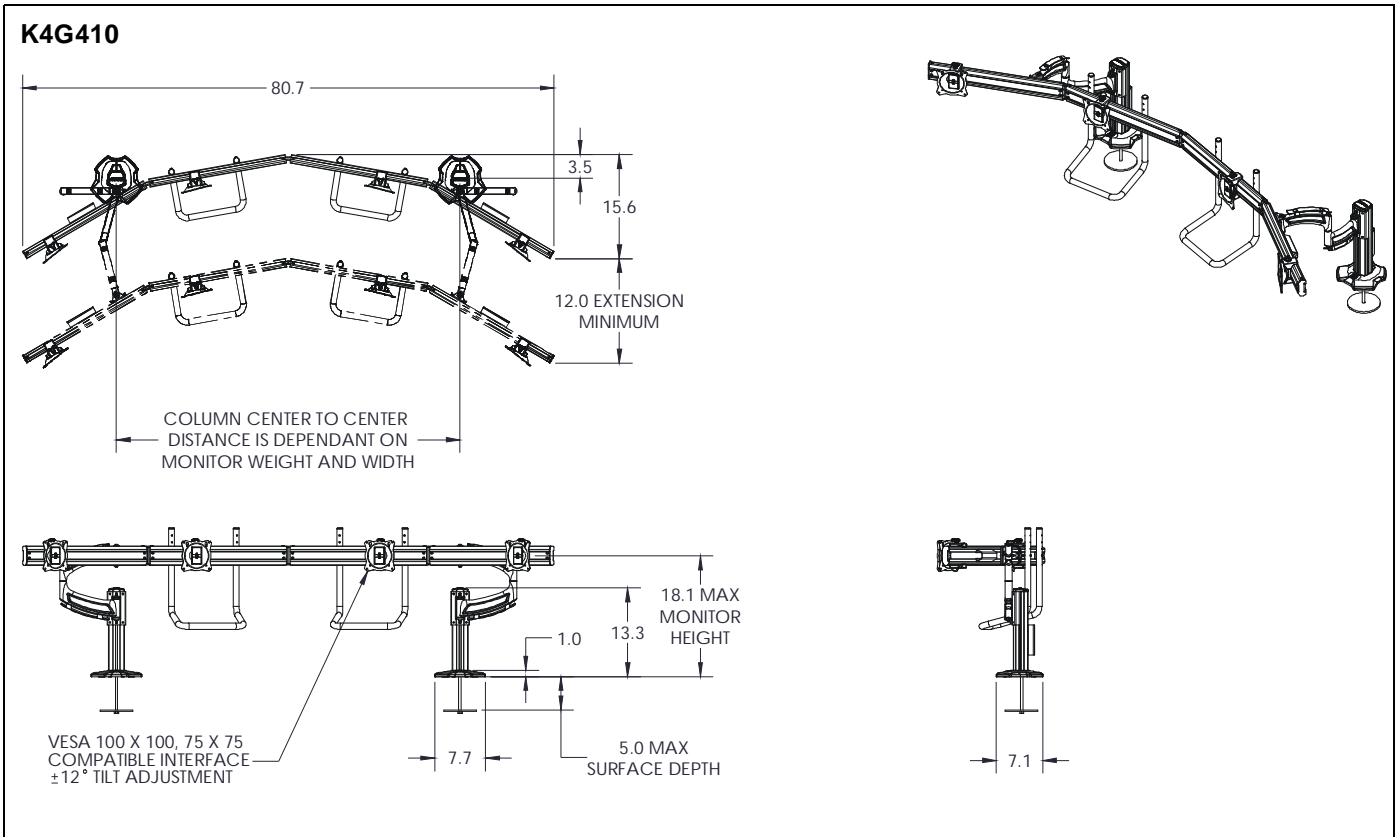



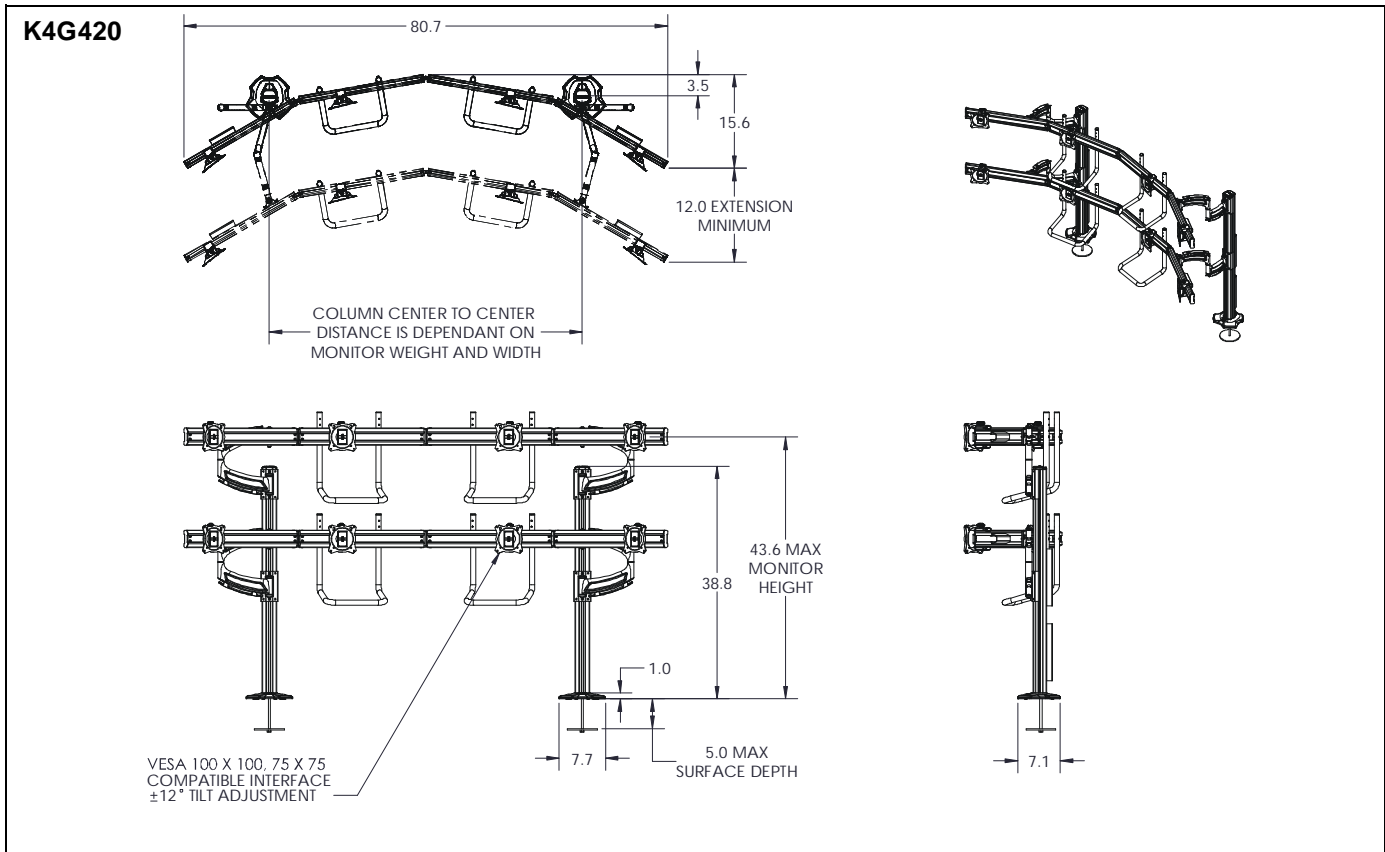
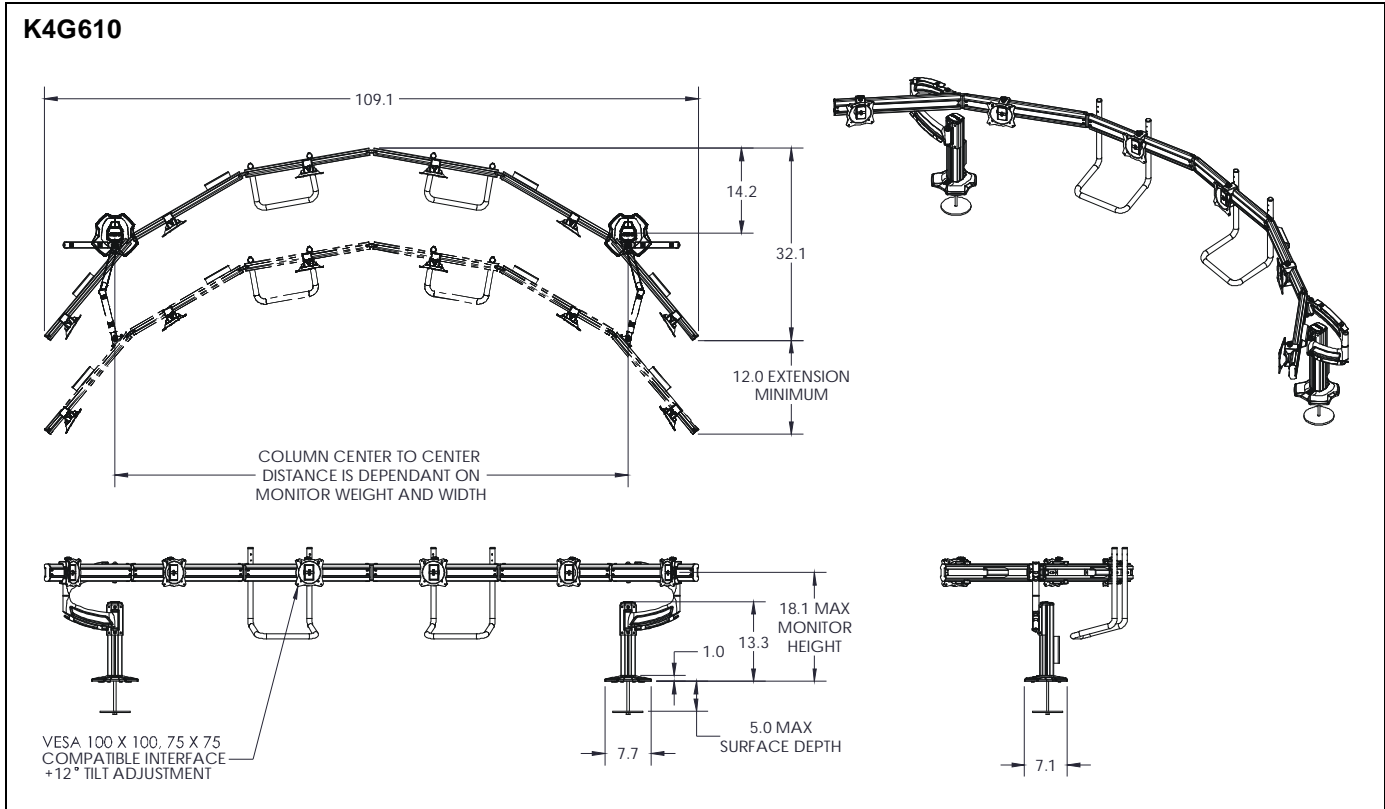



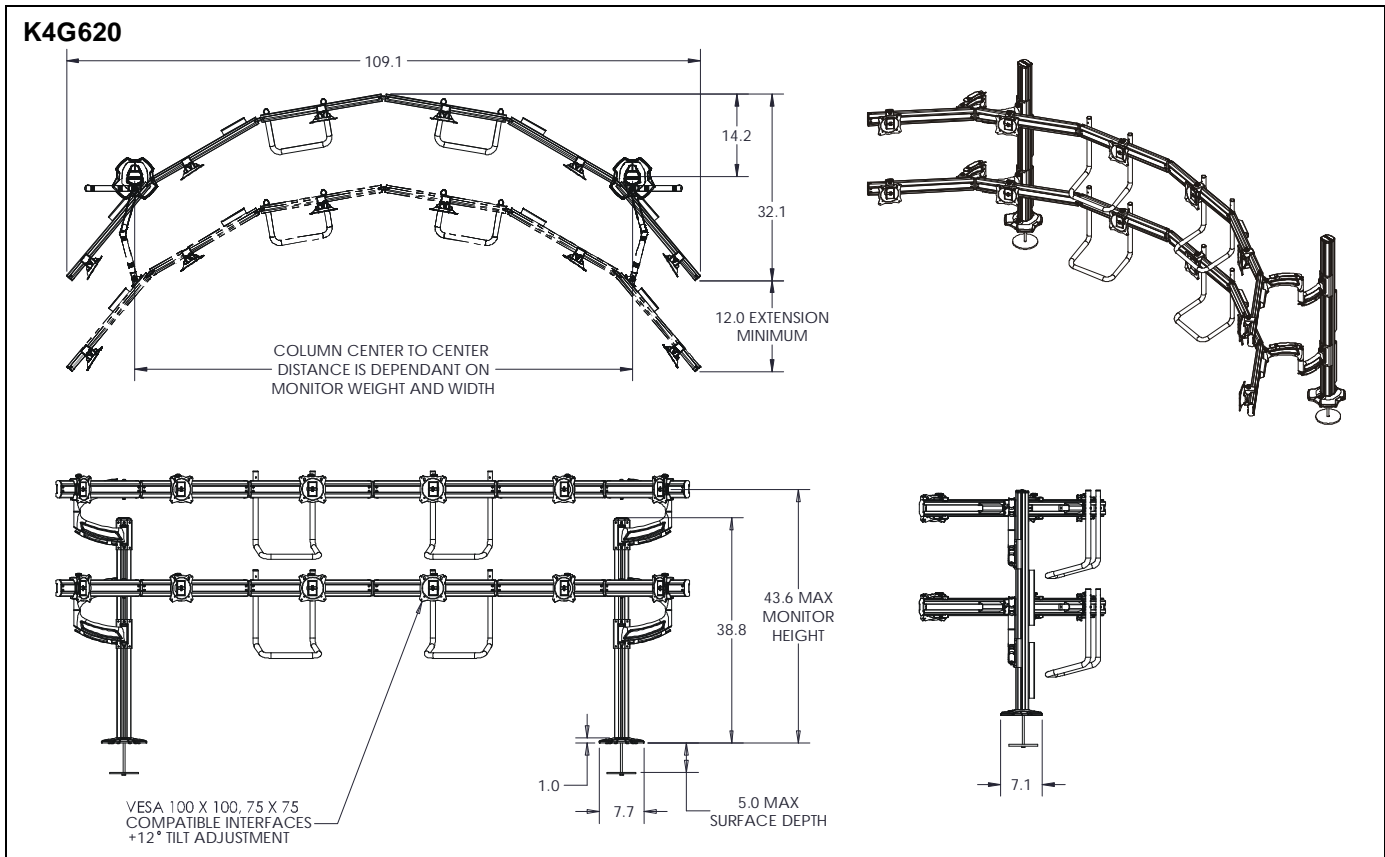
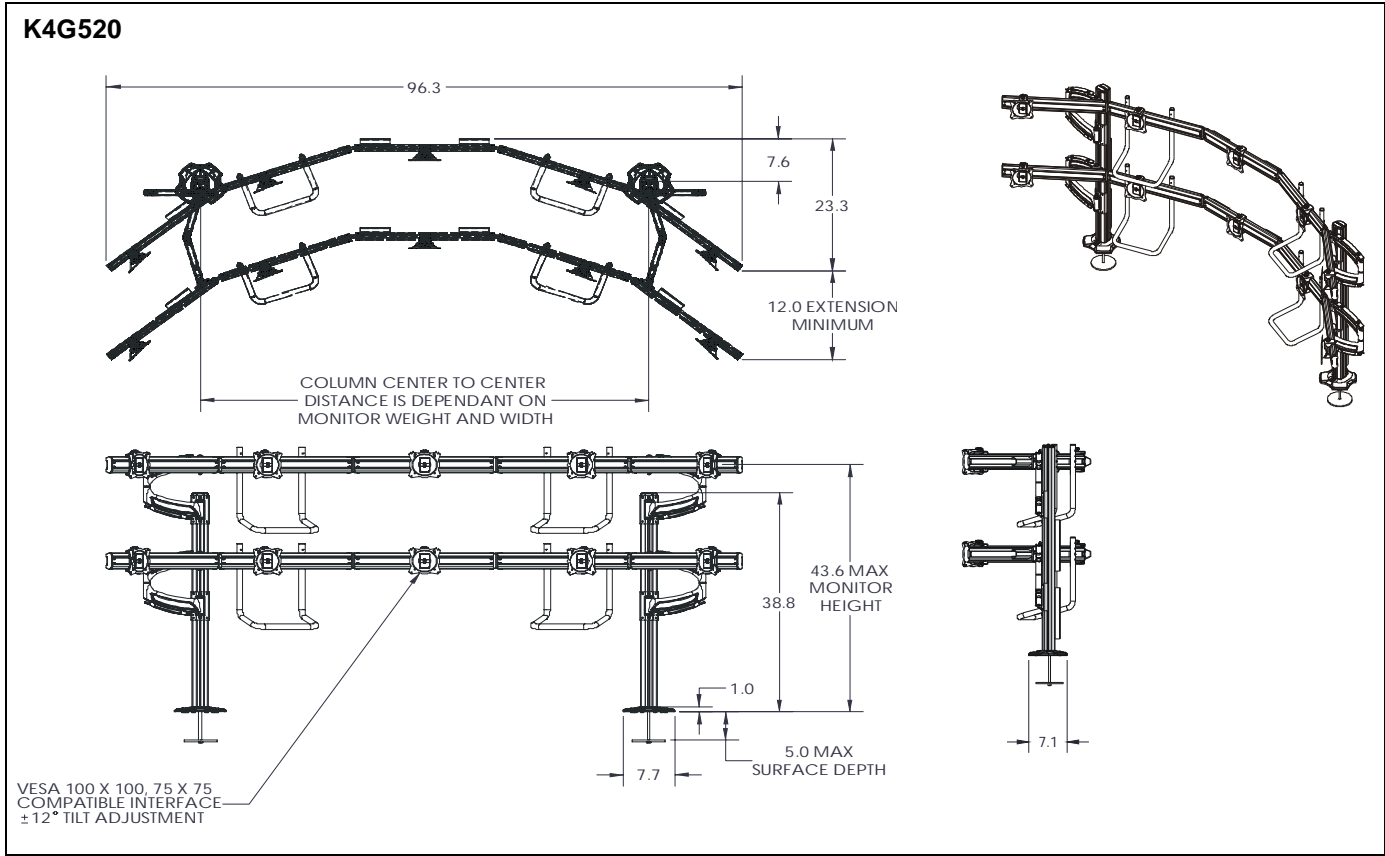



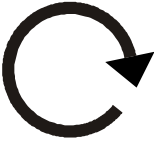

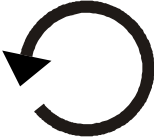
**DIMENSIONS (CONTINUED)**



**DIMENSIONS (CONTINUED)**



**LEGEND**

	<p><b>Tighten Fastener</b></p> <p>Apretar elemento de fijación</p> <p>Befestigungsteil festziehen</p> <p>Apertar fixador</p> <p>Serrare il fissaggio</p> <p>Bevestiging vastdraaien</p> <p>Serrez les fixations</p>		<p><b>Pencil Mark</b></p> <p>Marcar con lápiz</p> <p>Stiftmarkierung</p> <p>Marcar com lápis</p> <p>Segno a matita</p> <p>Potloodmerkteken</p> <p>Marquage au crayon</p>
	<p><b>Loosen Fastener</b></p> <p>Aflojar elemento de fijación</p> <p>Befestigungsteil lösen</p> <p>Desapertar fixador</p> <p>Allentare il fissaggio</p> <p>Bevestiging losdraaien</p> <p>Desserrez les fixations</p>		<p><b>Drill Hole</b></p> <p>Perforar</p> <p>Bohrloch</p> <p>Fazer furo</p> <p>Praticare un foro</p> <p>Gat boren</p> <p>Percez un trou</p>
	<p><b>Phillips Screwdriver</b></p> <p>Destornillador Phillips</p> <p>Kreuzschlitzschraubendreher</p> <p>Chave de fendas Phillips</p> <p>Cacciavite a stella</p> <p>Kruiskopschroevendraaier</p> <p>Tournevis à pointe cruciforme</p>		<p><b>Adjust</b></p> <p>Ajustar</p> <p>Einstellen</p> <p>Ajustar</p> <p>Regolare</p> <p>Afstellen</p> <p>Ajuster</p>
	<p><b>Open-Ended Wrench</b></p> <p>Llave de boca</p> <p>Gabelschlüssel</p> <p>Chave de bocas</p> <p>Chiave a punte aperte</p> <p>Steeksleutel</p> <p>Clé à fourche</p>		<p><b>Remove</b></p> <p>Quitar</p> <p>Entfernen</p> <p>Remover</p> <p>Rimuovere</p> <p>Verwijderen</p> <p>Retirez</p>
	<p><b>By Hand</b></p> <p>A mano</p> <p>Von Hand</p> <p>Com a mão</p> <p>A mano</p> <p>Met de hand</p> <p>À la main</p>		<p><b>Optional</b></p> <p>Opcional</p> <p>Optional</p> <p>Opcional</p> <p>Opzionale</p> <p>Optie</p> <p>En option</p>
	<p><b>Hex-Head Wrench</b></p> <p>Llave de cabeza hexagonal</p> <p>Sechskantschlüssel</p> <p>Chave de cabeça sextavada</p> <p>Chiave esagonale</p> <p>Zeskantsleutel</p> <p>Clé à tête hexagonale</p>		<p><b>Security Wrench</b></p> <p>Llave de seguridad</p> <p>Sicherheitsschlüssel</p> <p>Chave de segurança</p> <p>Chiave di sicurezza</p> <p>Veiligheidsleutel</p> <p>Clé de sécurité</p>

**TOOLS REQUIRED FOR INSTALLATION**

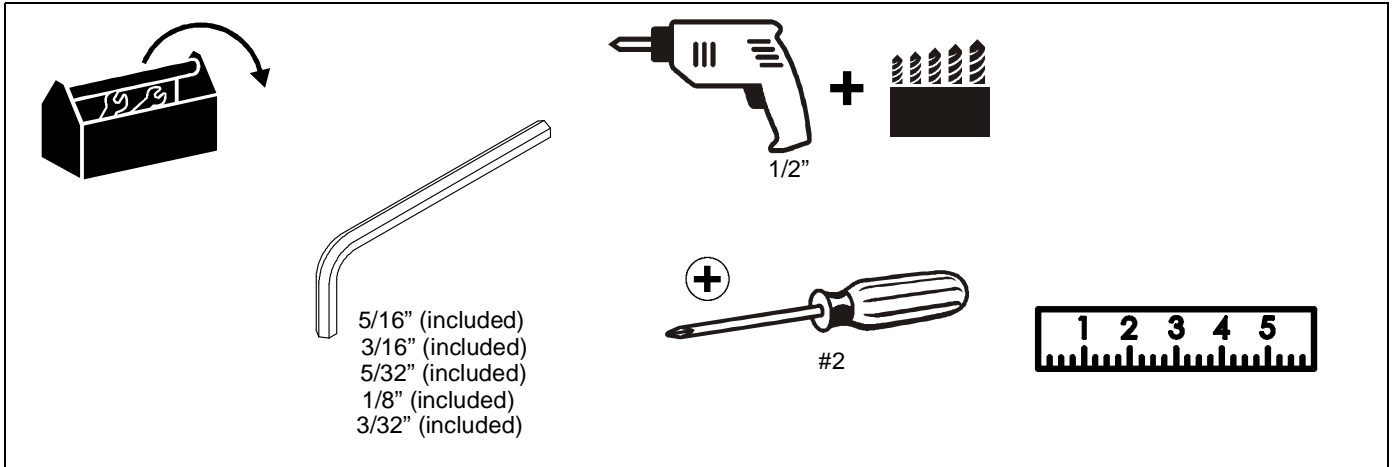

**PARTS**

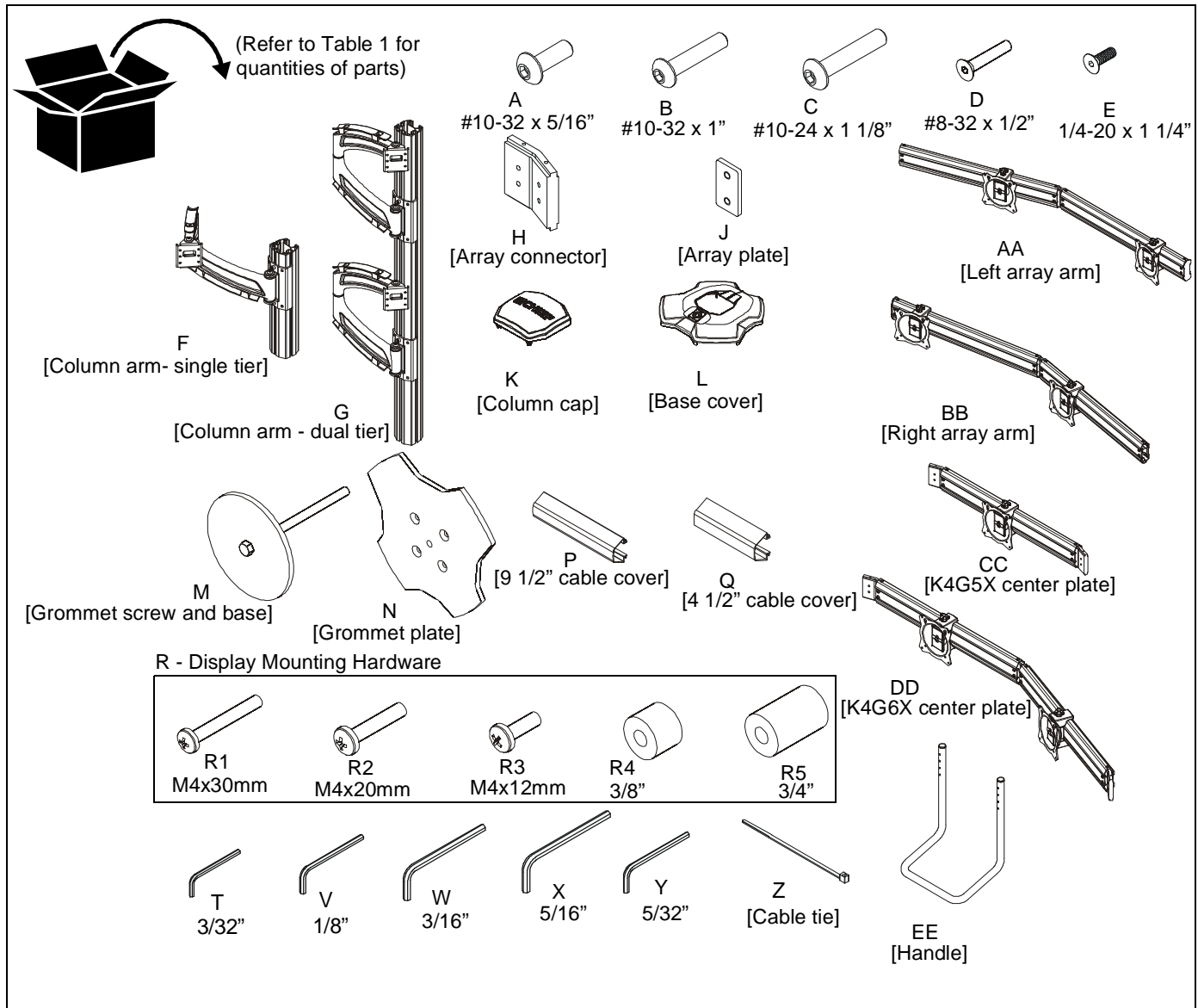

**Table 1: Parts**

ITEM	DESCRIPTION	K4G410	K4G510	K4G610	K4G420	K4G520	K4G620
A	Screw, Button Head Cap, #10-32 x 5/16"	4	4	4	8	8	8
B	Screw, Button Head Cap, #10-32 x 1"	4	4	4	8	8	8
C	Screw, Button Head Cap, #10-24 x 1 1/8"	4	4	4	8	8	8
D	Screw, Flat Head Cap, #8-32 x 1/2"	4	4	4	8	8	8
E	Screw, Flat Head Cap, 1/4-20 x 1 1/4"	8	8	8	8	8	8
F	Column Arm - Single Tier Models	2	2	2	-	-	-
G	Column Arm - Dual Tier Models	-	-	-	2	2	2
H	Array Connector	1	-	-	1	-	-
J	Array Plate	2	2	2	4	4	4
K	Column Cap	2	2	2	2	2	2
L	Base Cover	2	2	2	2	2	2
M	Grommet Screw and Base	2	2	2	2	2	2
N	Grommet Plate	2	2	2	2	2	2
P	Cable Management Cover, 9 1/2"	-	-	-	4	4	4
Q	Cable Management Cover, 4 1/2"	6	5	6	8	10	8
R	Kit, Array/Centris Faceplate Hardware (includes M1-M5)	4	5	6	8	10	12
R1	Screw, Phillips Pan Head, M4 x 30mm	16	20	24	32	40	48
R2	Screw, Phillips Pan Head, M4 x 20mm	16	20	24	32	40	48
R3	Screw, Phillips Pan Head, M4 x 12mm	16	20	24	32	40	48
R4	Spacer, 3/8"	16	20	24	32	40	48
R5	Spacer, 3/4"	16	20	24	32	40	48
T	Hex Key, 3/32"	1	1	1	1	1	1
V	Hex Key, 1/8"	1	1	1	1	1	1
W	Hex Key, 3/16"	1	1	1	1	1	1
X	Hex Key, 5/16"	1	1	1	1	1	1
Y	Hex Key, 5/32"	1	1	1	1	1	1
Z	Cable Tie	20	20	20	20	20	20
AA	Array Arm, Left	1	1	1	2	2	2
BB	Array Arm, Right	1	1	1	2	2	2
CC	Center Plate, K4G5X Models	-	1	-	-	2	-
DD	Center Plate, K4G6X Models	-	-	1	-	-	2
EE	Handle	2	2	2	4	4	4



### Assembly And Installation

1. Use four 1/4-20 x 1 1/4" flat head cap screws (E) to secure grommet plate (N) to column (F or G). Make sure longer legs of grommet plate are aligned with the front of column. (See Figure 1)

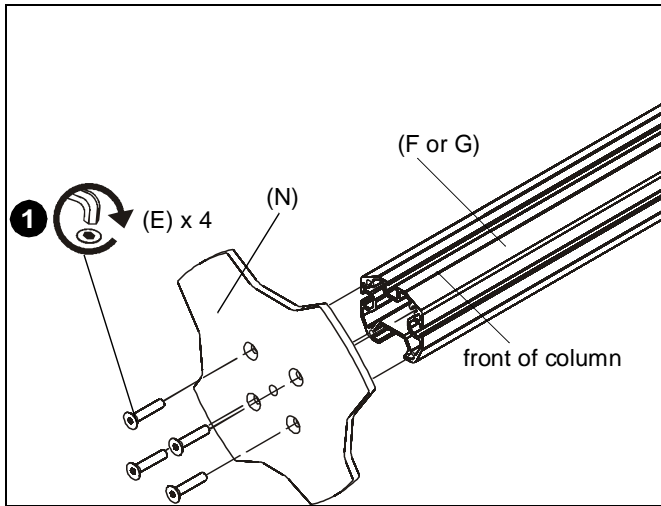

Figure 1

2. Repeat Step 1 for second column.
3. Locate a flat surface (thickness minimum of 1" to maximum of 5") on which to mount the array assembly.

**IMPORTANT ! :** Use the numbers provided in the table as a guide to determine distance between columns (F or G). Exact distances may vary slightly with other monitors in order to achieve a level mount.



**WARNING:** The K4G4X-5X-6X Series mounts were designed to mount displays between 19-23" in width. Do NOT install displays smaller than 19" in width or larger than 23" in width!

**NOTE:** Column 1 shows monitor "width" not diagonal size.

Monitor Width (in.)	Average Weight (lb)	K4G410 (in.)	K4G510 (in.)	K4G610 (in.)
19	7	52.5	68	69.5
20	8	54	68	72.25
21	8	56.25	68	75.5
22	8.5	57.75	68.75	77.5
23	9	59.25	69.75	77.5

**IMPORTANT ! :** Mounts must be installed parallel to each other on the desk. (See Figure 2)

**NOTE:** Table assumes a average display depth of 2.35".

4. If a hole doesn't already exist, drill a hole in desk with a diameter between 1/2" and 3" at desired mounting location. (See Figure 2)
5. Position mount on desk so that center hole of grommet plate (N) is centered over grommet hole. (See Figure 2)
6. Insert grommet screw (M) through grommet hole and thread into center hole of grommet plate (N). (See Figure 2)
7. Tighten grommet screw (M) until grommet base is tightened against underside of desk and mount is securely mounted to desk. (See Figure 2)
8. Repeat Steps 4-7 for to install second column.

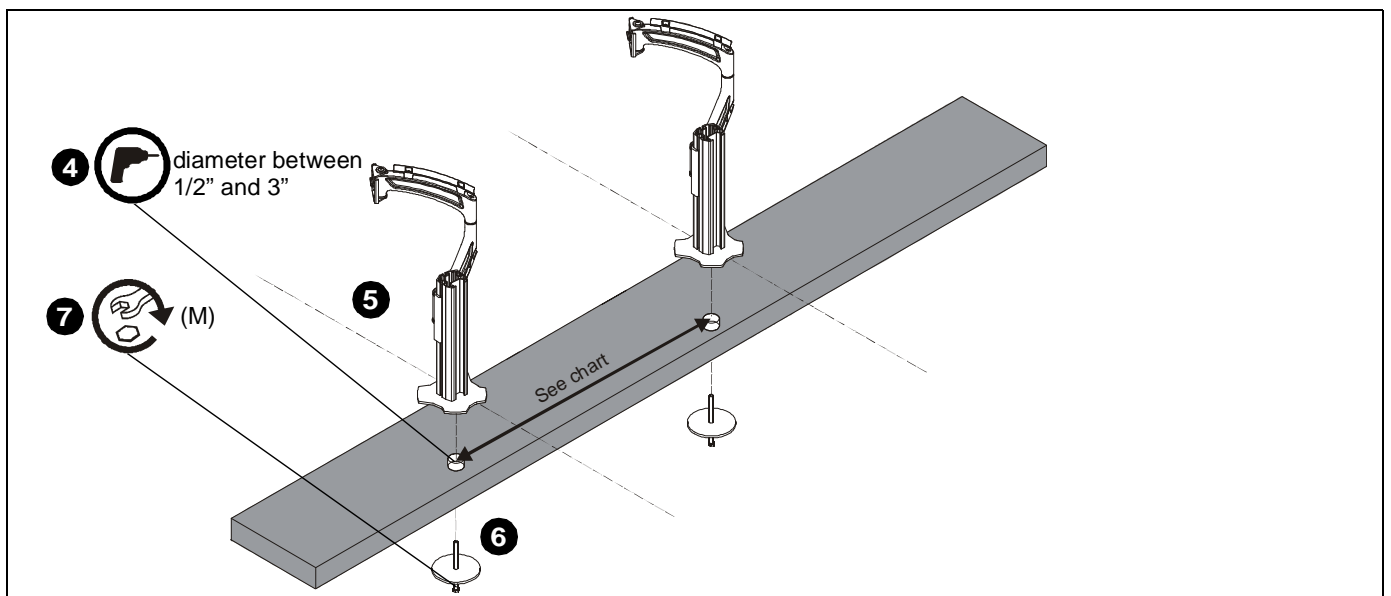

Figure 2

9. Carefully manipulate base cover (L) to create an opening large enough to wrap cover around array column. (See Figure 3)
10. Wrap base cover (L) around column and slide it down until base cover fits securely onto grommet plate (N). (See Figure 3)

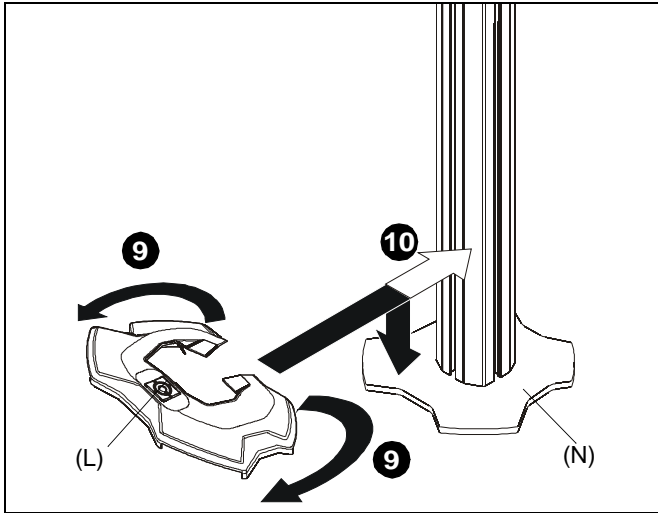

Figure 3

11. Tighten two socket head cap screws to secure column arms (F or G) at desired height. (See Figure 4)
12. Install column cap (K) to column (F or G). (See Figure 4)

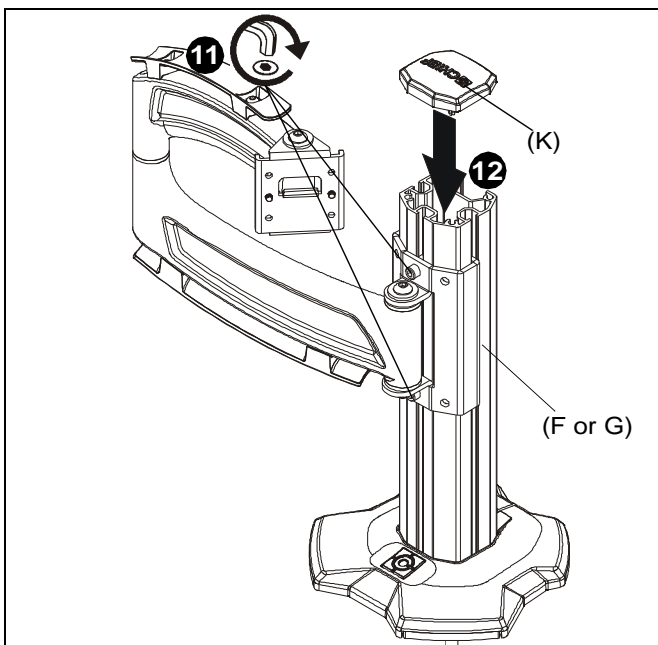

Figure 4

13. Repeat Steps 9-12 for second column.
14. Hang right and left array arms (AA and BB) onto column arm (F or G) faceplates using the mounting tab on the faceplate. (See Figure 5)

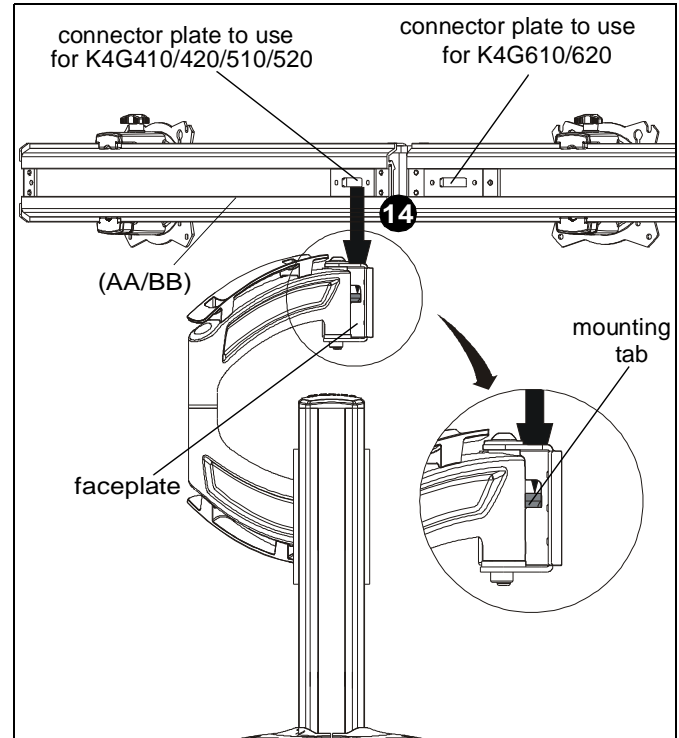

Figure 5

**IMPORTANT !** : Connect faceplates to the outer array arms as shown in Figure 5 when installing K4G410/420/510/520 mounts. Connect faceplates to the inner array arms when installing K4G610/620 mounts. Minor adjustments to the connection location may need to be made in order to compensate for sagging. See Display Leveling Section for details.

15. Use two #10-32 x 5/16" button head cap screws (A) to loosely secure column arms (F or G) to outside arrays (AA and BB). (See Figure 6)

**IMPORTANT !** : Do not tighten screws at this time!

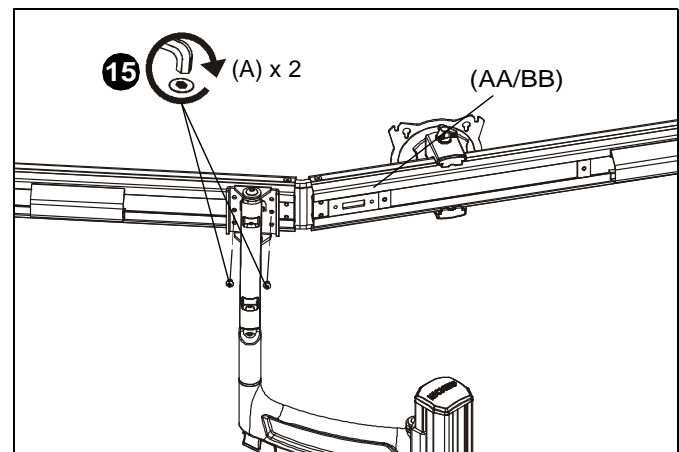

Figure 6

16. Insert array connector (H) [K4G410/420 models] or connectors pre-installed on both end of center plates (CC or DD) into left and right array arm openings. (See Figure 7)
17. Slide array plates (J) into grooves on back of array arms, lining up holes on plates with holes in arms. (See Figure 7)

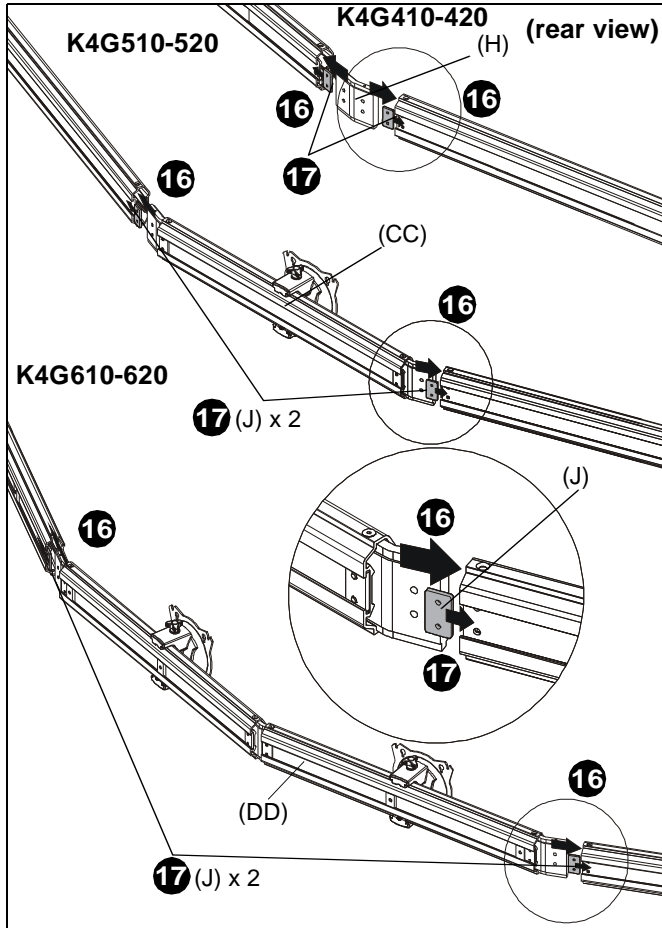

Figure 7

18. Use two #8-32 x 1/2" flat head cap screws (D) to secure each array arm to connector plates. (See Figure 8) and (See Figure 9)
19. Use four #10-24 x 1 1/8" button head cap screws (C) to secure array arms (AA and BB) to connector plates and brackets. (See Figure 8) and (See Figure 9)

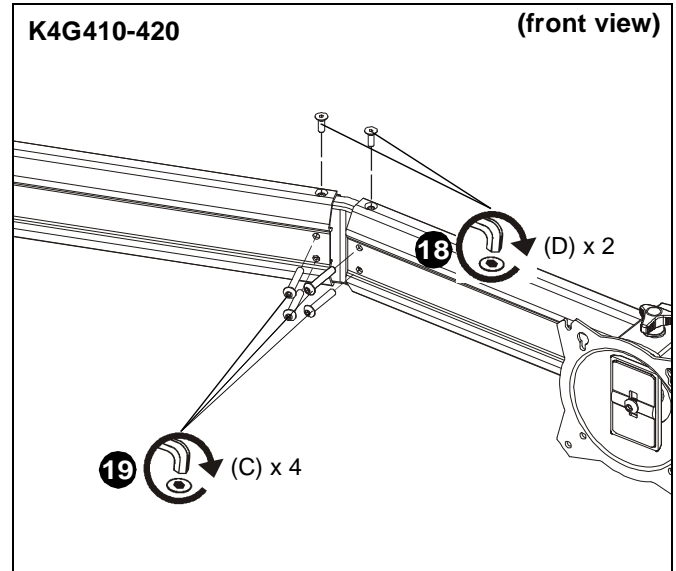

Figure 8

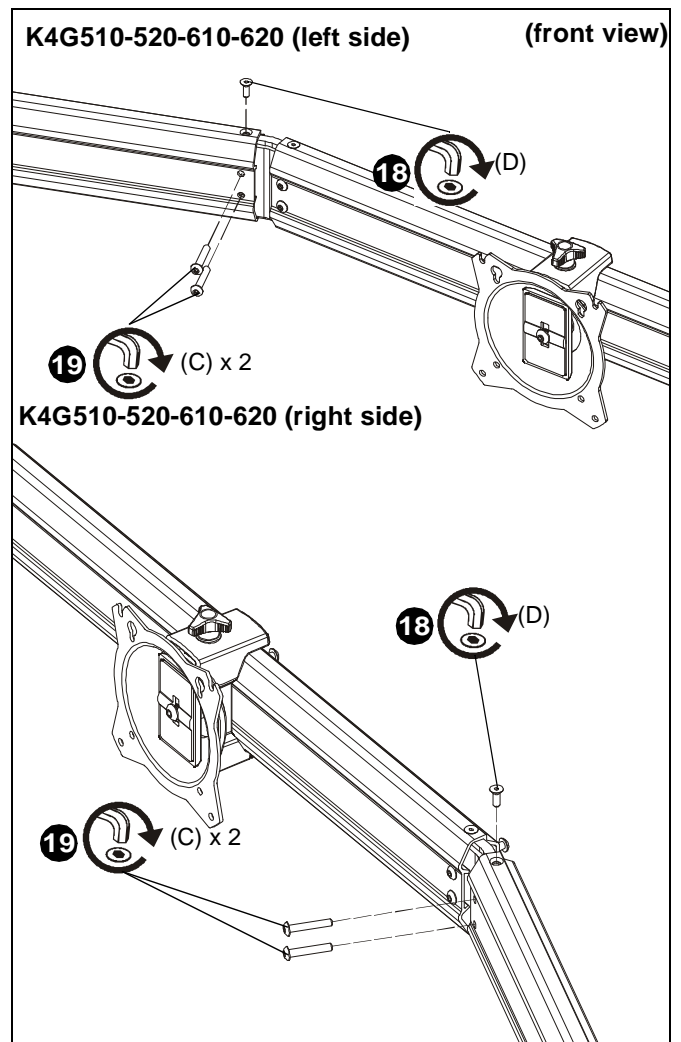

Figure 9

20. Use four #10-32 x 1" button head cap screws (B) to secure two handles (EE) to array arms (AA and BB) or K4G6X center plate (DD). (See Figure 9)

**NOTE:** Handles attach to right and left arrays (AA and BB) for all K4G4 and K4G5 models. Handles attach to K4G6X center plate for K4G6X models.

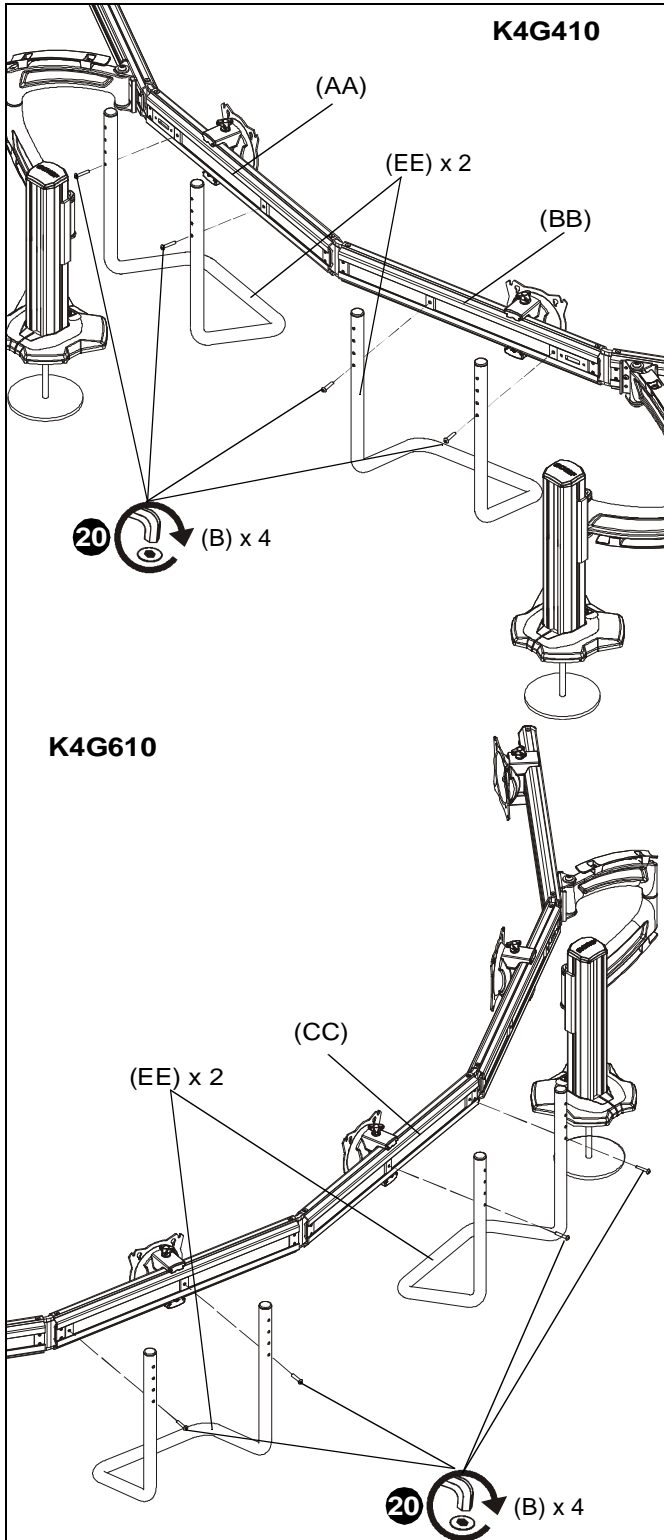

Figure 10

## Display Installation



**WARNING:** Exceeding the weight capacity can result in serious personal injury or damage to equipment! It is the installer's responsibility to make sure the combined weight of all components located on the K4G4X-5X-6X Series mounts up to (and including) the display does not exceed 15 lbs (6.8 kg) per display.



**CAUTION:** Using screws of improper size may damage your display! Proper screws will easily thread into display mounting holes.

**NOTE:** Supplied screws (R1, R2 and R3) may not fit properly for all displays. See display's operating instructions for details.

### Flush Mounting Holes

1. Position faceplate in desired mounting position. Adjust as required before proceeding. See Height Adjustment Section for details.
2. Using Phillips screwdriver, carefully install two M4 x 12mm Phillips pan machine screws (R3) into the *upper* mounting holes on the display. Thread screws completely into display, then back out 3 complete turns. (See Figure 11)

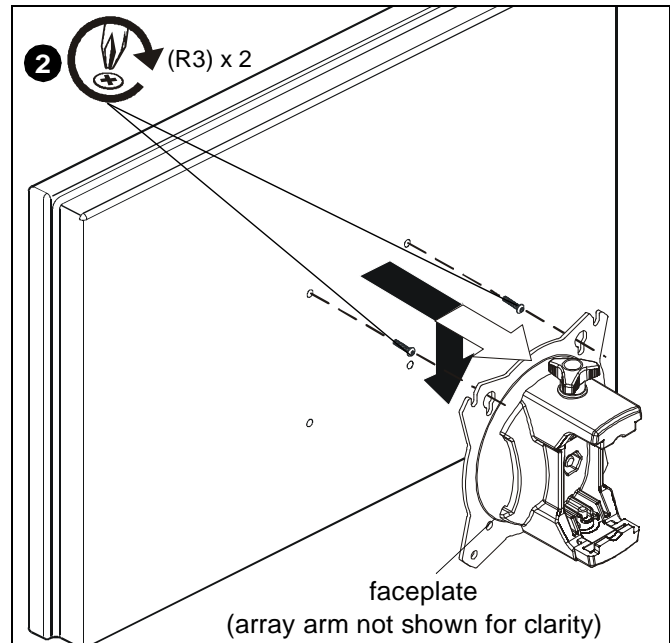

Figure 11

3. Pick up and align display so that screws (R3) (installed on the back of the display in the previous step) fit into the mounting holes on the faceplate. Lower the display firmly into place. (See Figure 11)

- Using Phillips screwdriver, install two M4x12 mm Phillips pan machine screws (R3) through the *lower* mounting holes on faceplate into the display. (See Figure 12)

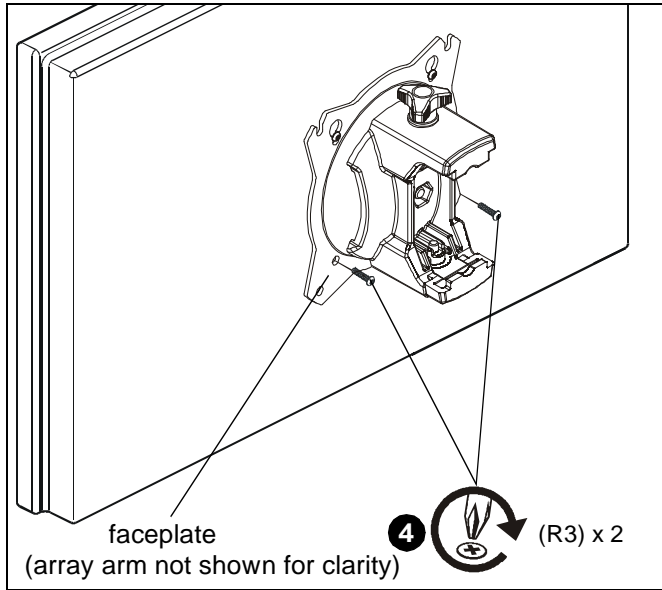

Figure 12

- Tighten all four screws (R3). Do not over-tighten!

**NOTE:** If roll adjustment is desired for center faceplate, do not tighten screws.

- Repeat Steps 1-5 for other displays.
- Proceed to Cable Management Section.

**Recessed Mounting Holes**

**NOTE:** If faceplate does not fit into recessed area of display, proceed with the steps in this section.

- Determine depth of recessed mounting holes relative to back surface of display (against which faceplate will contact).
- Select proper length spacer and screw from table below:

**NOTE:** All spacers used should be the same length. If the recess depths result in multiple spacer lengths, then select the longer spacer.

IF recess DEPTH is:	THEN use spacer:	AND screw:
3/8" or less	R4 (3/8" long)	R2 (M4 x 20mm)
More than 3/8" up to and including 3/4"	R5 (3/4" long)	R1 (M4 x 30mm)



**CAUTION:** Using screws of improper size may damage your display! Proper screws will easily and completely thread into display mounting holes.

- Using Phillips screwdriver, carefully install two selected screws (R1 or R2) through selected spacers (R4 or R5) into the *upper* mounting holes on the display. Thread screws completely into display, then back out 3 complete turns. (See Figure 13)

- Pick up and align display so that screws (R1 or R2) (installed on the back of the display in the previous step) fit into the mounting holes on the faceplate. Lower the display firmly into place. (See Figure 13)

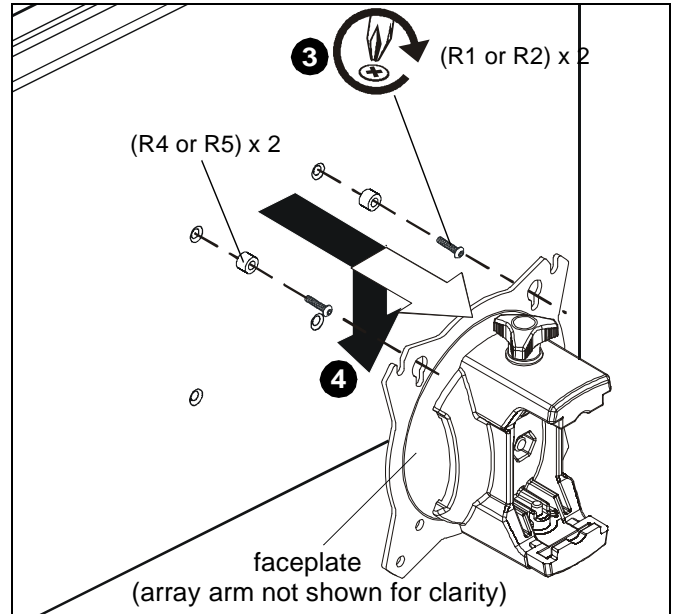

Figure 13

- Slide two remaining selected spacers (R4 or R5) in between faceplate and display, positioning them over the *lower* two mounting holes. (See Figure 14)
- Install two remaining selected screws (R1 or R2) through *lower* two mounting holes on faceplate, selected spacers (R4 or R5) into the *lower* mounting holes on the display. (See Figure 14)

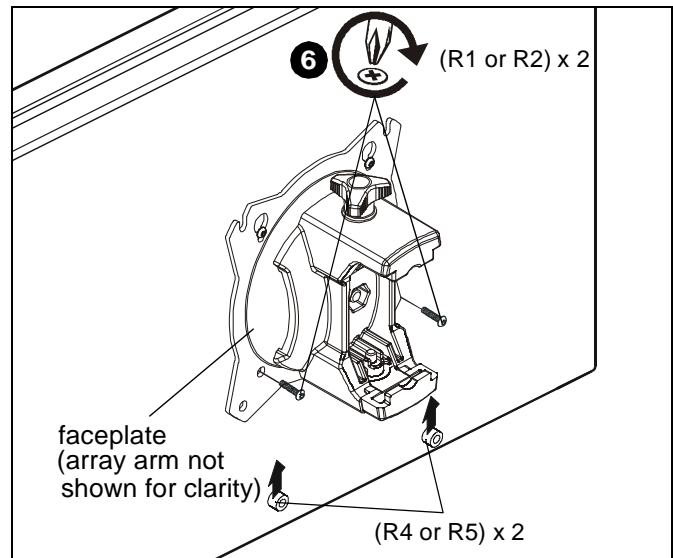

Figure 14

- Tighten all four screws. Do not over-tighten!

## Adjustments

### Pivot Adjustment (Column Arm)

1. Use handles (EE) to extend or collapse column arms as desired. (See Figure 15)
2. (Optional) Loosen or tighten column arm pivot tension screws as desired to increase or decrease pivot tension. (See Figure 15)

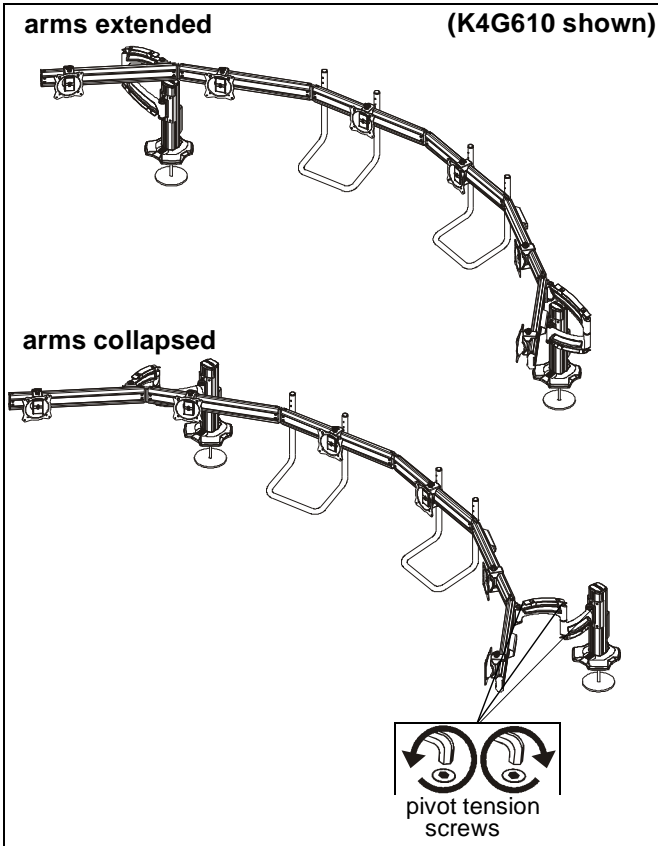

Figure 15

### Height Adjustment

1. Loosen socket head cap screws holding column arm to column. (See Figure 16)
2. Adjust column arm to desired height. (See Figure 16)
3. Tighten socket head cap screws to lock column arm's position. (See Figure 16)

**NOTE:** The height on both columns should be adjusted simultaneously to ensure a level mount.

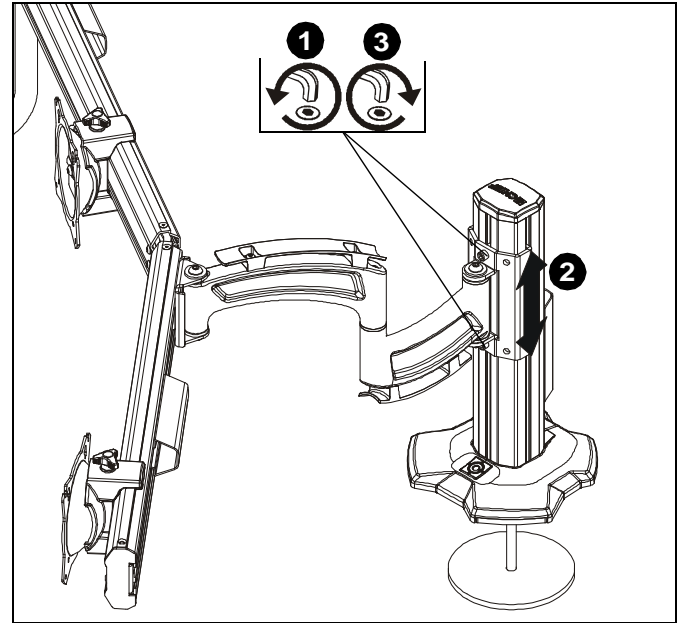

Figure 16

### Faceplate Assembly Removal

1. Remove socket head cap screw from bottom of faceplate assembly. (See Figure 17)
2. Slide out removable plate from bottom of faceplate assembly. (See Figure 17)

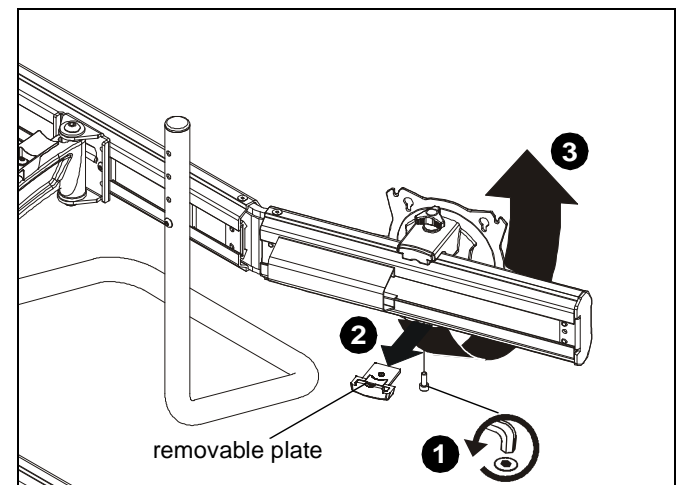
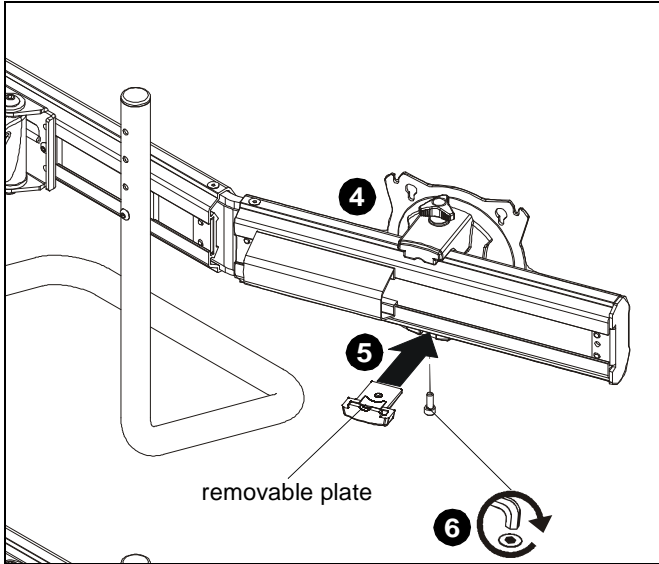

Figure 17

3. Remove faceplate assembly from array arm. (See Figure 17)

**To Reattach Faceplate Assembly**

4. Place faceplate assembly on array arm at desired mounting position. (See Figure 18)
5. Slide removable plate back into slot at bottom of faceplate assembly. (See Figure 18)
6. Reinstall socket head cap screw removed in Step 1 to secure faceplate assembly to array arm. (See Figure 18)



**Figure 18**

**Lateral Shift**

1. Loosen knob on top of faceplate assembly until faceplate can slide freely along array. (See Figure 19)
2. Adjust lateral position as desired. (See Figure 19)
3. Tighten knob to secure lateral position. (See Figure 19)

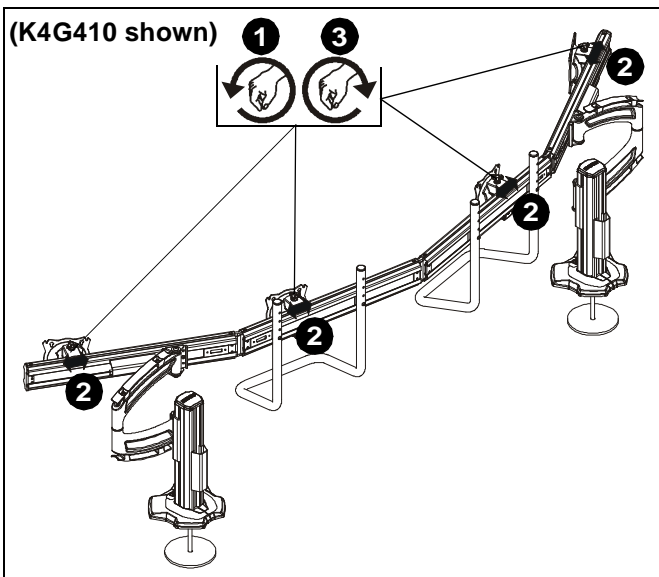

**Figure 19**

**Pitch/Roll/Yaw Adjustment**

1. Loosen knob on top of faceplate assembly. (See Figure 20)
2. Adjust pitch, roll and/or yaw as desired. (See Figure 20)
3. Tighten knob to secure desired faceplate position. (See Figure 20)

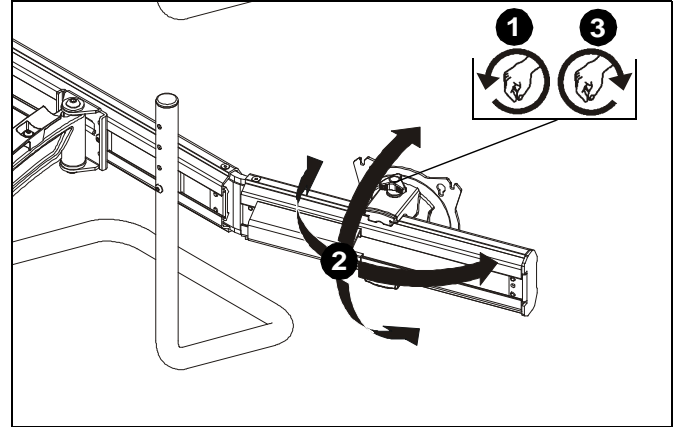

**Figure 20**

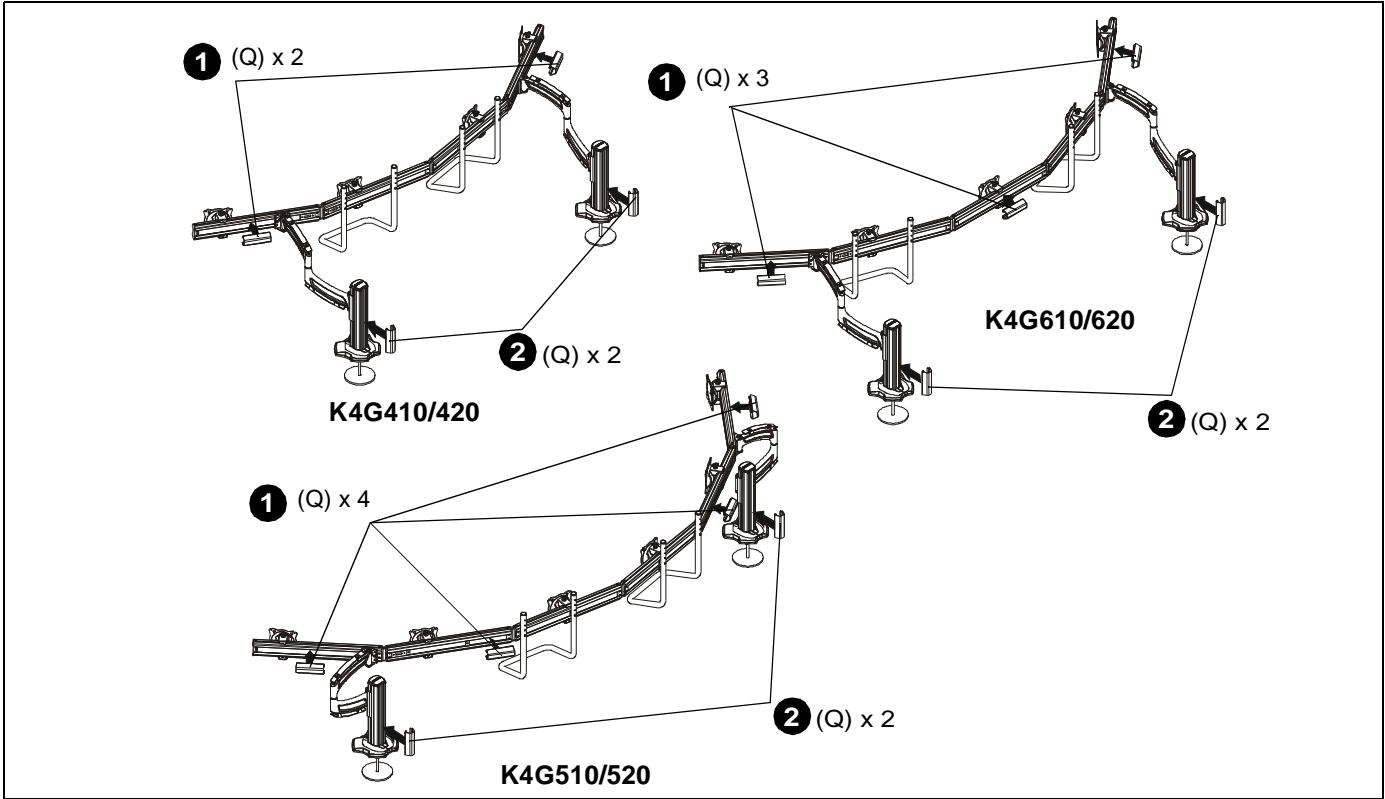

Figure 21

**Cable Management**

1. Install 4 1/2" cable covers (Q) to array arms. (See Figure 21)
2. Install two 4 1/2" cable covers (Q) to single tier column arms (F) or four 9 1/2" cable covers (P) to dual tier column arms (G). (See Figure 21) or (See Figure 22)

3. Route cables from display through cable management covers (Q) on array arms as desired. (See Figure 23)
4. Route cables along swing arms, using cable ties (Z) to secure cables to arms. (See Figure 23)
5. Route cables through cable management covers (P or Q) on columns as desired. (See Figure 23)

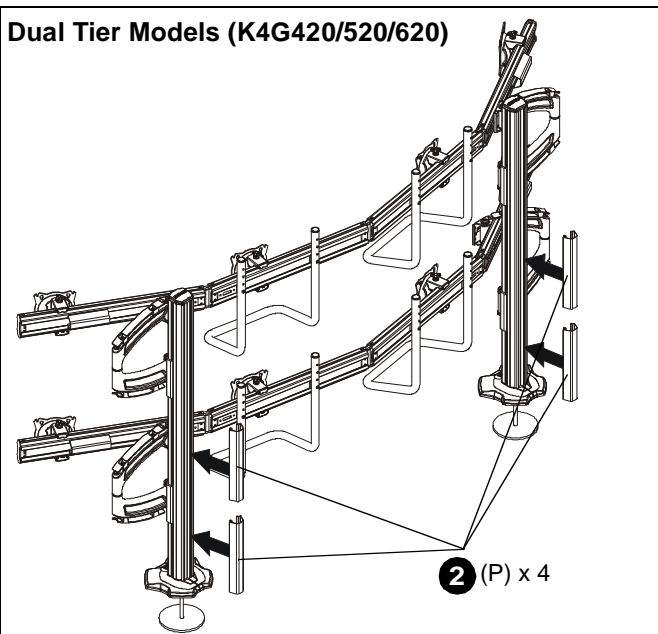

Figure 22

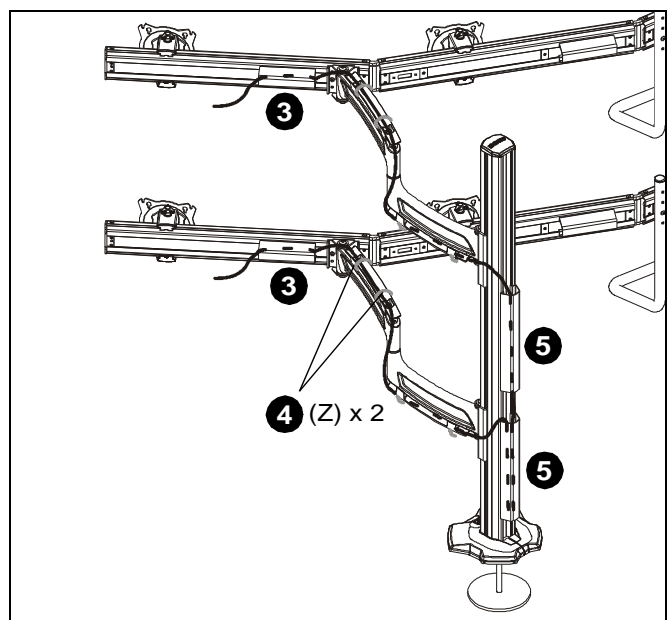

Figure 23



### Display Leveling

If the array sags after attaching displays, adjust the connection point to the arms until an even mount is achieved. Refer to the appropriate section depending on whether the array sags to the inside or the outside. (See Figure 24)

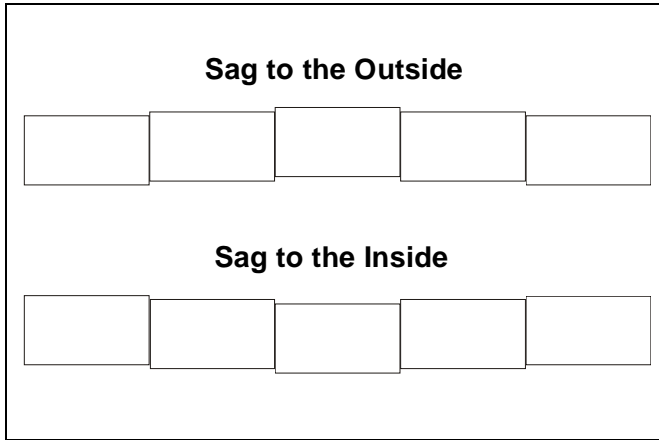

Figure 24

### For Sag to the Outside

1. Loosen two screws holding column arms to outer array arms. (See Figure 25)
2. Lift up on array arm slightly and slide connection plate towards the outside of the array until an even mount is achieved. (See Figure 25)
3. Tighten two screws holding column arms to outer array arms. (See Figure 25)

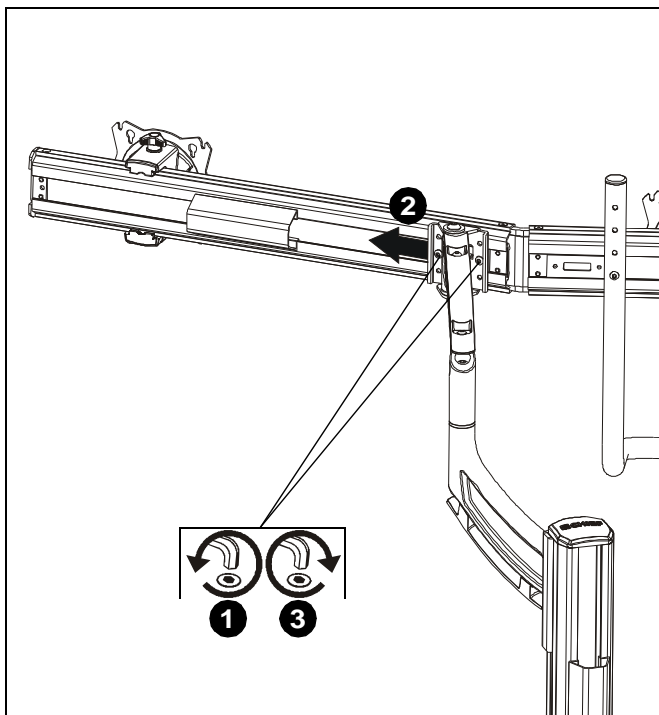

Figure 25

### For Sag to the Inside

4. Loosen two screws holding column arms to outer array arms. (See Figure 26)
5. Lift up on array arm slightly and slide connection plate towards the inside of the array until an even mount is achieved. (See Figure 26)
6. Tighten two screws holding column arms to outer array arms. (See Figure 26)

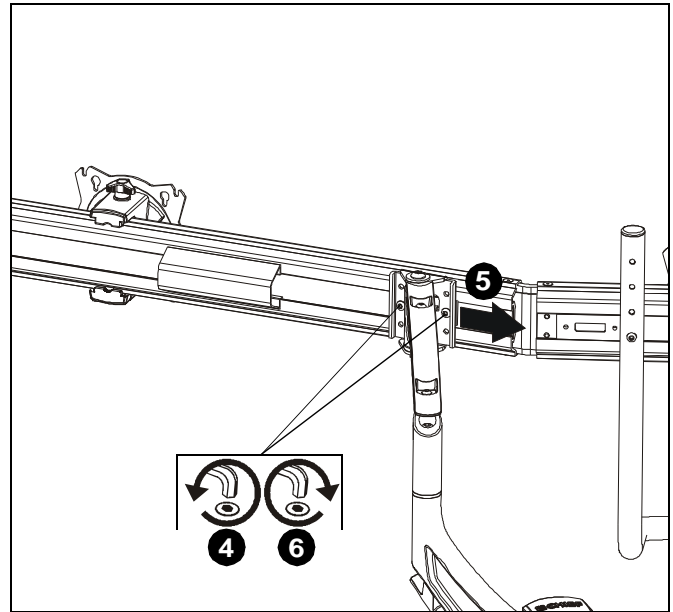

Figure 26

**NOTE:** If the mount still sags, it may be necessary to move one or both of the connection points to the other bar of the array.

**IMPORTANT ! :** Remove all displays from array prior to moving the faceplate connection from one array bar to the other.







Our Mounts. **Your Vision.**

Chief, a products division of  
Milestone AV Technologies

8800-002432 Rev00  
©2014 Milestone AV Technologies  
[www.chiefmfg.com](http://www.chiefmfg.com)  
04/14

<b>USA/International</b>	<b>A</b> 6436 City West Parkway, Eden Prairie, MN 55344 <b>P</b> 800.582.6480 / 952.225.6000 <b>F</b> 877.894.6918 / 952.894.6918
<b>Europe</b>	<b>A</b> Franklinstraat 14, 6003 DK Weert, Netherlands <b>P</b> +31 (0) 495 580 852 <b>F</b> +31 (0) 495 580 845
<b>Asia Pacific</b>	<b>A</b> Office No. 918 on 9/F, Shatin Galleria 18-24 Shan Mei Street Fotan, Shatin, Hong Kong <b>P</b> 852 2145 4099 <b>F</b> 852 2145 4477

