

---

# INSTALLATION INSTRUCTIONS

---

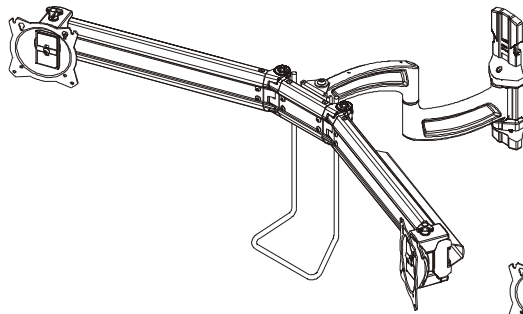

K4W210

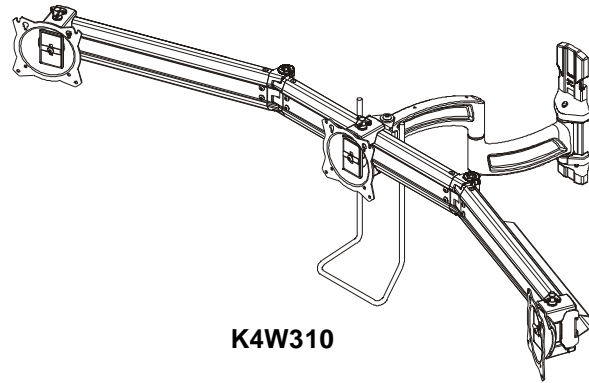

K4W310

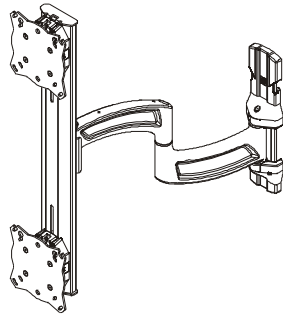

K4W120

---

## Kontour™ Articulating Array Arm Wall Series

---

## DISCLAIMER

Milestone AV Technologies and its affiliated corporations and subsidiaries (collectively "Milestone"), intend to make this manual accurate and complete. However, Milestone makes no claim that the information contained herein covers all details, conditions or variations, nor does it provide for every possible contingency in connection with the installation or use of this product. The information contained in this document is subject to change without notice or obligation of any kind. Milestone makes no representation of warranty, expressed or implied, regarding the information contained herein. Milestone assumes no responsibility for accuracy, completeness or sufficiency of the information contained in this document.

Chief® is a registered trademark of Milestone AV Technologies. All rights reserved.

## IMPORTANT SAFETY INSTRUCTIONS

 **WARNING:** A WARNING alerts you to the possibility of serious injury or death if you do not follow the instructions.

 **CAUTION:** A CAUTION alerts you to the possibility of damage or destruction of equipment if you do not follow the corresponding instructions.

 **WARNING:** Failure to read, thoroughly understand, and follow all instructions can result in serious personal injury, damage to equipment, or voiding of factory warranty! It is the installer's responsibility to make sure all components are properly assembled and installed using the instructions provided.

 **WARNING:** Failure to provide adequate structural strength for this component can result in serious personal injury or damage to equipment! It is the installer's responsibility to make sure the structure to which this component is attached can support five times the combined weight of all equipment. Reinforce the structure as required before installing the component.

 **WARNING:** Exceeding the weight capacity can result in serious personal injury or damage to equipment! It is the installer's responsibility to make sure the combined weight of all components located on the K4W Series mount up to (and including) the display does not exceed 15 lbs (6.8 kg) per display.

 **WARNING:** Use this mounting system only for its intended use as described in these instructions. Do not use attachments not recommended by the manufacturer.

 **WARNING:** Never operate this mounting system if it is damaged. Return the mounting system to a service center for examination and repair.

 **WARNING:** The wall to which the mount is being attached may have a maximum drywall thickness of 5/8" (1.6cm). Do not install drywall anchors into the seam between drywall pieces.

**IMPORTANT ! :** The K4W Series mounts are designed to be mounted to an 8" concrete, 8"x 8"x 16" concrete block or 2" x 4" wood studs.

 **WARNING:** Do not use this product outdoors.

**--SAVE THESE INSTRUCTIONS--**

**DIMENSIONS**

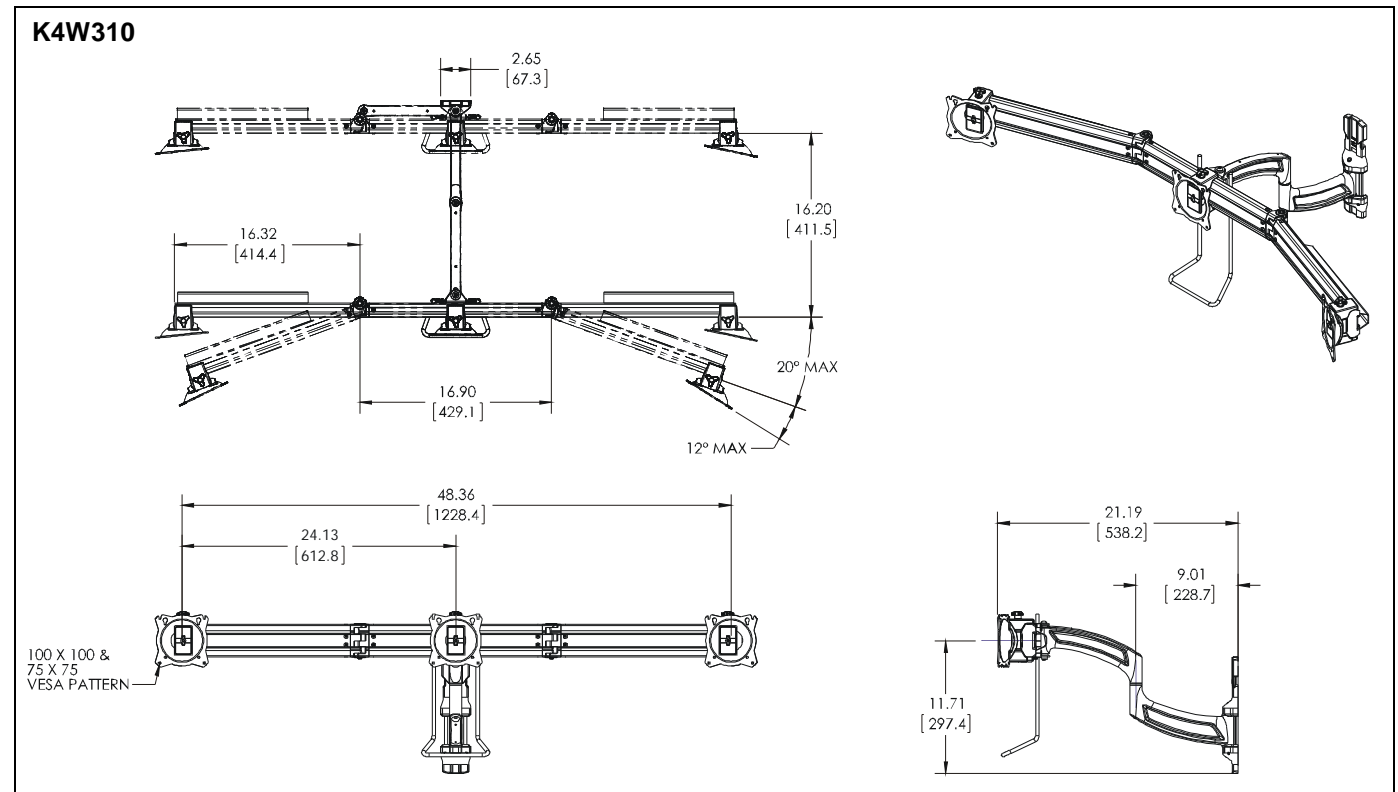
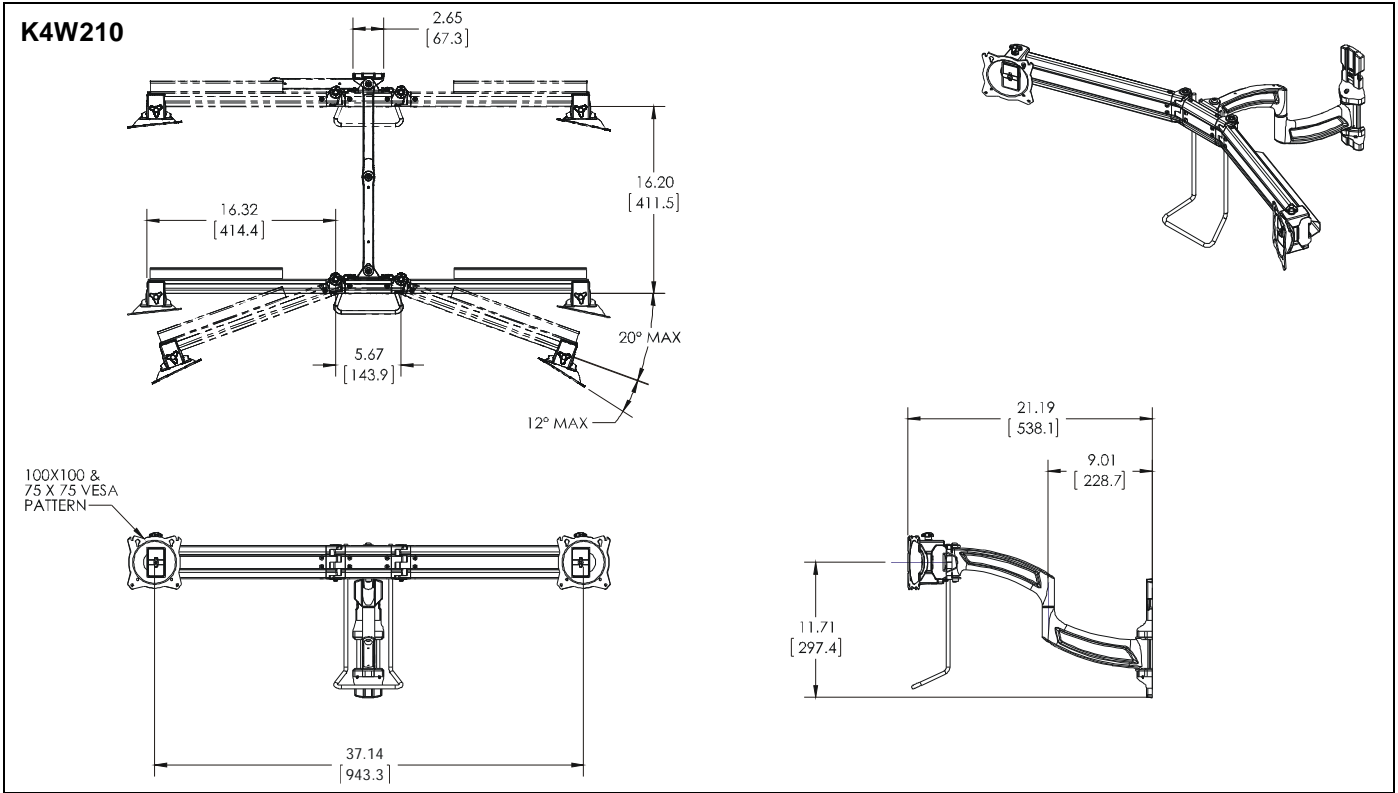

**DIMENSIONS (CONTINUED)**

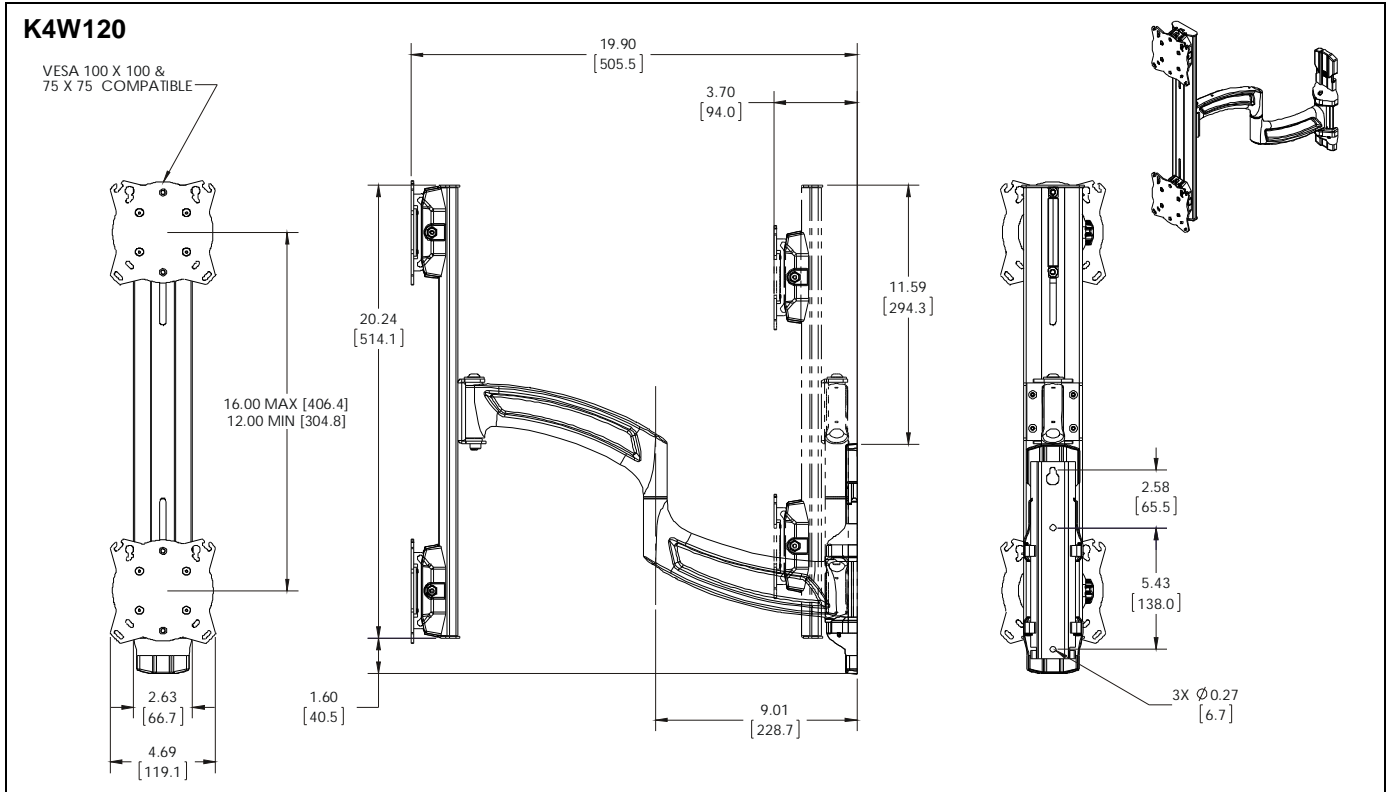

**LEGEND**

	<p><b>Tighten Fastener</b></p> <p>Apretar elemento de fijación</p> <p>Befestigungsteil festziehen</p> <p>Apertar fixador</p> <p>Serrare il fissaggio</p> <p>Bevestiging vastdraaien</p> <p>Serrez les fixations</p>		<p><b>Pencil Mark</b></p> <p>Marcar con lápiz</p> <p>Stiftmarkierung</p> <p>Marcar com lápis</p> <p>Segno a matita</p> <p>Potloodmerkten</p> <p>Marquage au crayon</p>
	<p><b>Loosen Fastener</b></p> <p>Aflojar elemento de fijación</p> <p>Befestigungsteil lösen</p> <p>Desapertar fixador</p> <p>Allentare il fissaggio</p> <p>Bevestiging losdraaien</p> <p>Desserrez les fixations</p>		<p><b>Drill Hole</b></p> <p>Perforar</p> <p>Bohrloch</p> <p>Fazer furo</p> <p>Praticare un foro</p> <p>Gat boren</p> <p>Percez un trou</p>
	<p><b>Phillips Screwdriver</b></p> <p>Destornillador Phillips</p> <p>Kreuzschlitzschraubendreher</p> <p>Chave de fendas Phillips</p> <p>Cacciavite a stella</p> <p>Kruiskopschroevendraaier</p> <p>Tournevis à pointe cruciforme</p>		<p><b>Adjust</b></p> <p>Ajustar</p> <p>Einstellen</p> <p>Ajustar</p> <p>Regolare</p> <p>Afstellen</p> <p>Ajuster</p>
	<p><b>Open-Ended Wrench</b></p> <p>Llave de boca</p> <p>Gabelschlüssel</p> <p>Chave de bocas</p> <p>Chiave a punte aperte</p> <p>Steeksleutel</p> <p>Clé à fourche</p>		<p><b>Remove</b></p> <p>Quitar</p> <p>Entfernen</p> <p>Remover</p> <p>Rimuovere</p> <p>Verwijderen</p> <p>Retirez</p>
	<p><b>By Hand</b></p> <p>A mano</p> <p>Von Hand</p> <p>Com a mão</p> <p>A mano</p> <p>Met de hand</p> <p>À la main</p>		<p><b>Optional</b></p> <p>Opcional</p> <p>Optional</p> <p>Opcional</p> <p>Opzionale</p> <p>Optie</p> <p>En option</p>
	<p><b>Hex-Head Wrench</b></p> <p>Llave de cabeza hexagonal</p> <p>Sechskantschlüssel</p> <p>Chave de cabeça sextavada</p> <p>Chiave esagonale</p> <p>Zeskantsleutel</p> <p>Clé à tête hexagonale</p>		<p><b>Security Wrench</b></p> <p>Llave de seguridad</p> <p>Sicherheitsschlüssel</p> <p>Chave de segurança</p> <p>Chiave di sicurezza</p> <p>Veiligheidsleutel</p> <p>Clé de sécurité</p>

**TOOLS REQUIRED FOR INSTALLATION**

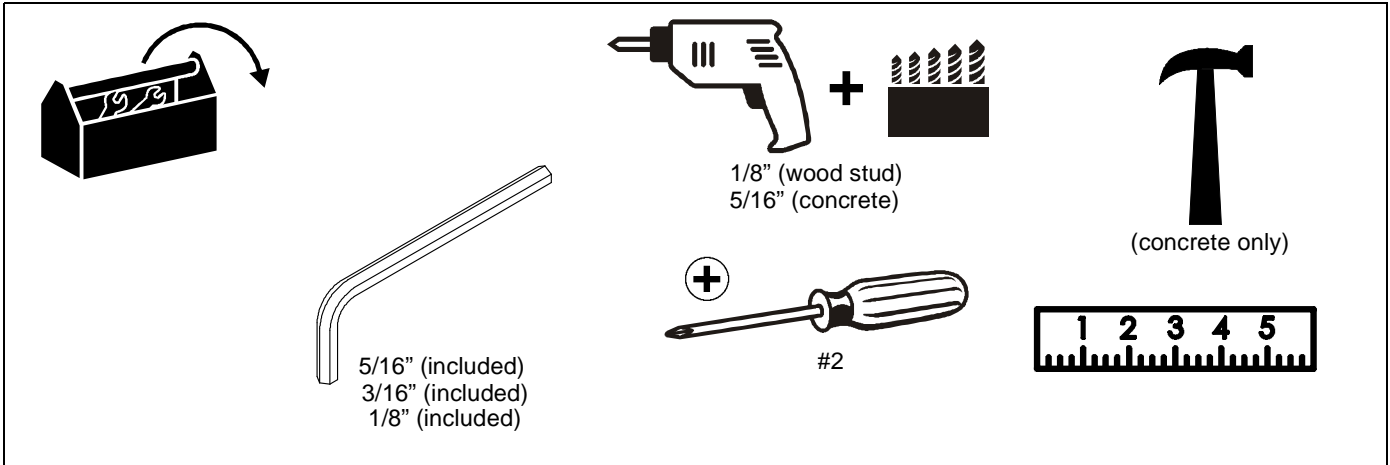

**PARTS**

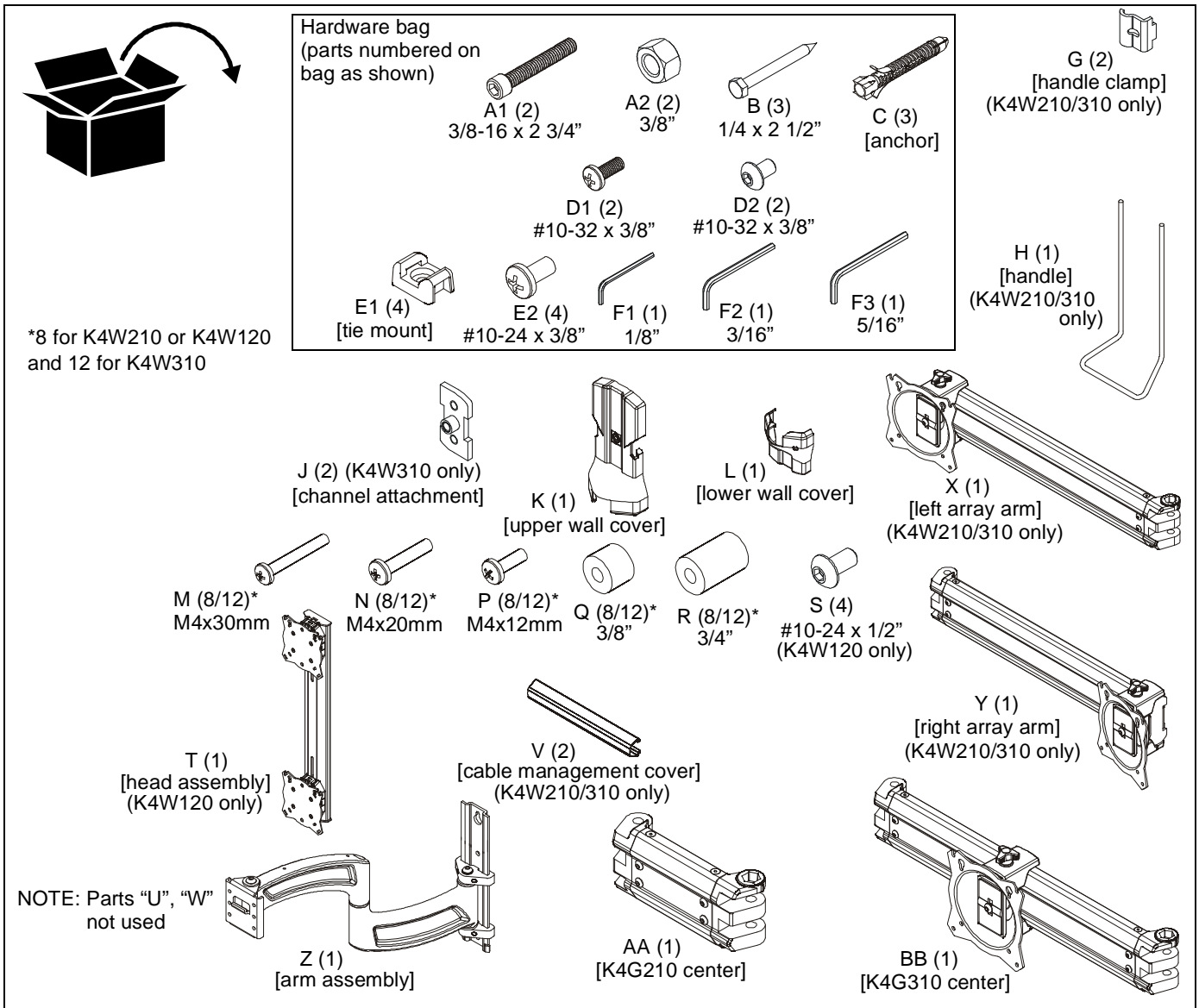

## Assembly And Installation

### Install to Wall

#### Install Arm Assembly to Wall - Wood Studs



**WARNING:** Failure to provide adequate structural strength for this component can result in serious personal injury or damage to equipment! It is the installer's responsibility to make sure the structure to which this component is attached can support five times the combined weight of all equipment. Reinforce the structure as required before installing the component. The wall to which the mount is being attached may have a maximum drywall thickness of 5/8" (1.6cm).

1. Determine mounting location.
2. Measure 1" above desired center line of display and mark a hole at desired mounting location on the center of wood stud. (See Figure 1)

**IMPORTANT ! :** Use a level to make sure arm assembly (Z) is level when mounted to the wall!

**IMPORTANT ! :** The K4W Series mounts are designed to be mounted to a 2" x 4" wood stud wall.

3. Drill one 1/8" diameter hole at location marked in Step 2 with a depth of 1 3/4". (See Figure 1)

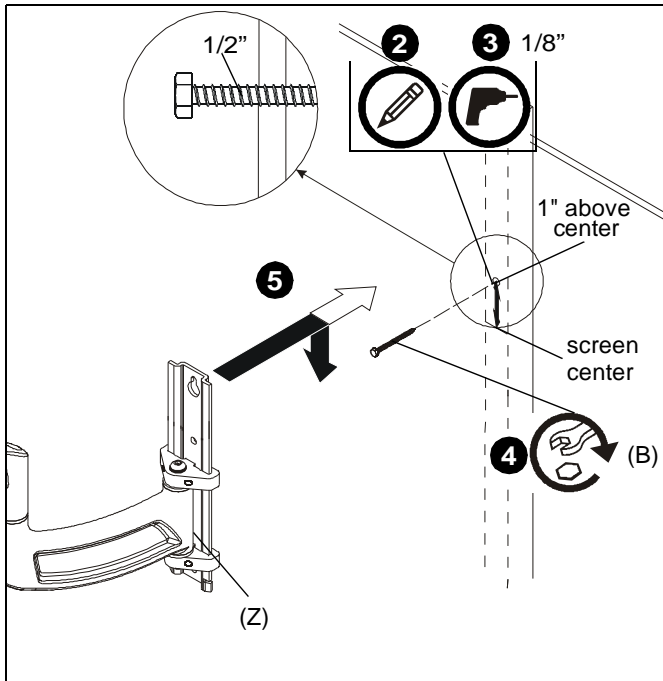

Figure 1

4. Install one 1/4 x 2 1/2" lag bolt (B) into hole, leaving screw hanging out 1/2" from the wall. (See Figure 1)
5. Hang arm assembly (Z) onto lag bolt (B) by latching key-shaped hole over top of bolt. (See Figure 1)
6. Mark two holes at lower mounting hole locations. (See Figure 2)
7. Remove arm assembly (Z) from wall.

8. Drill two 1/8" holes at locations marked in Step 6. (See Figure 2)
9. Hang arm assembly (Z) back onto wall.
10. Install two 1/4 x 2 1/2" lag bolts (B) into holes drilled in Step 8 to secure mount to wall. (See Figure 2)
11. Tighten all three lag bolts (B) to fully secure mount to wall.

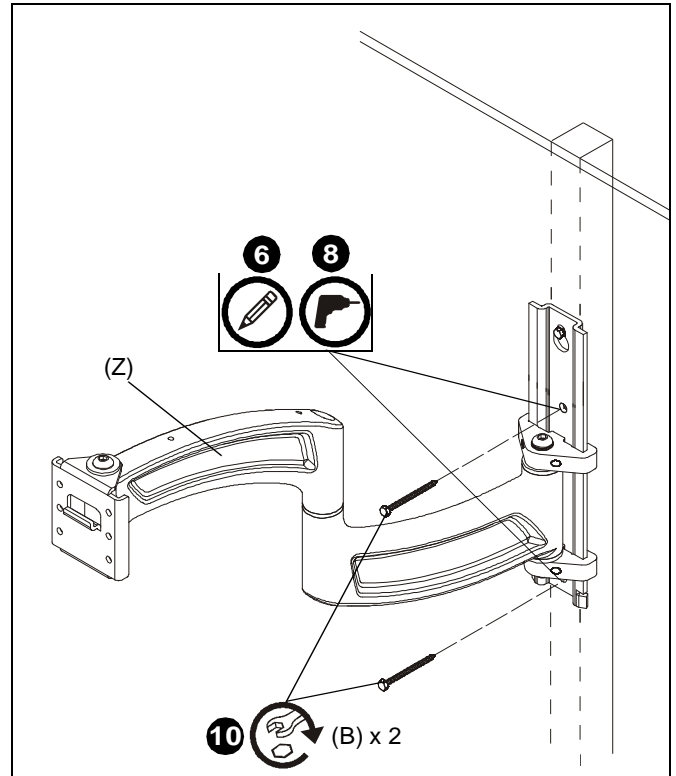

Figure 2

12. Proceed ahead to corresponding Installation to Arm Section.

### Install Arm Assembly to Wall - Hollow Concrete Block or Poured Concrete

**WARNING:** Failure to provide adequate structural strength for this component can result in serious personal injury or damage to equipment! It is the installer's responsibility to make sure the structure to which this component is attached can support five times the combined weight of all equipment. Reinforce the structure as required before installing the component.

**WARNING:** The wall to which the mount is being attached may have a maximum drywall thickness of 5/8" (1.6cm). Do not install drywall anchors into the seam between drywall pieces.

**WARNING:** INSTALLING A K4W SERIES MOUNT INTO UNDERRATED OR DAMAGED CONCRETE CAN LEAD TO SERIOUS INJURY OR DAMAGE TO PRODUCT! Never install a K4W Series mount into cracked, chipped or flaking concrete.

1. Determine mounting location.
2. Measure 1" above desired center line and mark a hole at desired mounting location. (See Figure 3)

**IMPORTANT ! :** Use a level to make sure arm assembly (Z) is level when mounted to the wall!

**IMPORTANT ! :** The K4W Series mounts are designed to be mounted to an 8" concrete or 8"x 8"x 16" concrete block wall.

3. Drill one 5/16" diameter hole at location marked in Step 2 with a depth of 3 1/4". (See Figure 3)

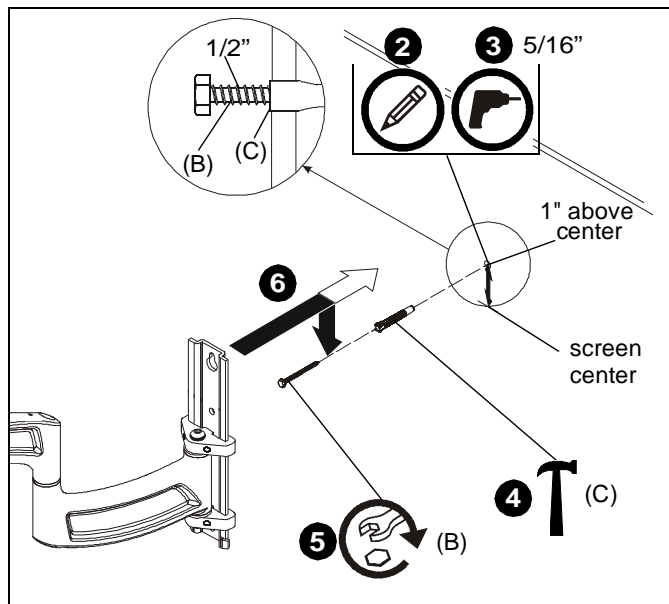

Figure 3

5. Install one 1/4 x 2 1/2" lag bolt (B) into concrete anchor (C), leaving bolt hanging out 1/2" from the wall. (See Figure 3)
6. Hang arm assembly (Z) onto lag bolt (B) by latching key-shaped hole over top of bolt. (See Figure 3)
7. Mark two holes at lower mounting hole locations. (See Figure 4)
8. Remove arm assembly (Z) from wall.
9. Drill two 5/16" holes at marked locations. (See Figure 4)
10. Install two concrete anchors (C) into holes. (See Figure 4)
11. Hang arm assembly (Z) back onto wall.
12. Install two 1/4 x 2 1/2" lag bolts (B) into concrete anchors (C) to secure mount to wall. (See Figure 4)
13. Tighten all lag bolts (B) to fully secure mount to wall.

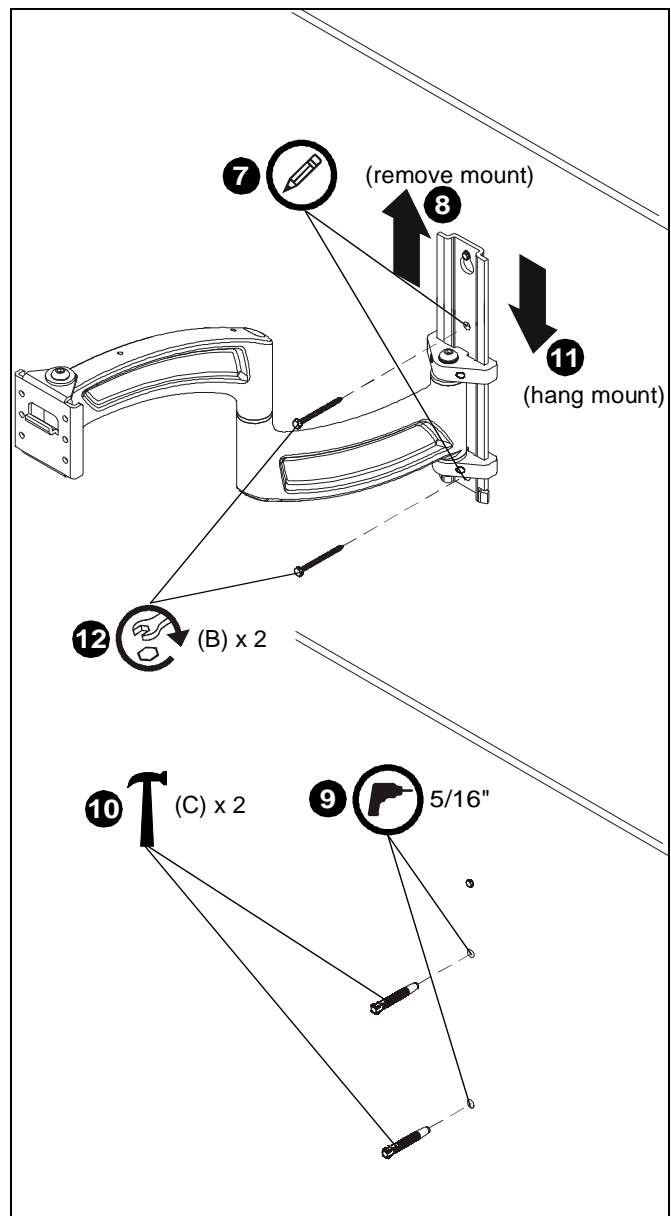

Figure 4

4. Install one concrete anchor (C) into drilled hole. (See Figure 3)



**K4W210/310 Installation to Arm**

1. Use two 3/8-16 x 2 3/4" socket head carriage screws (A1) and two 3/8" lock nuts (A2) to secure left array arm (X) and right array arm (Y) to array center (AA or BB). (See Figure 5)

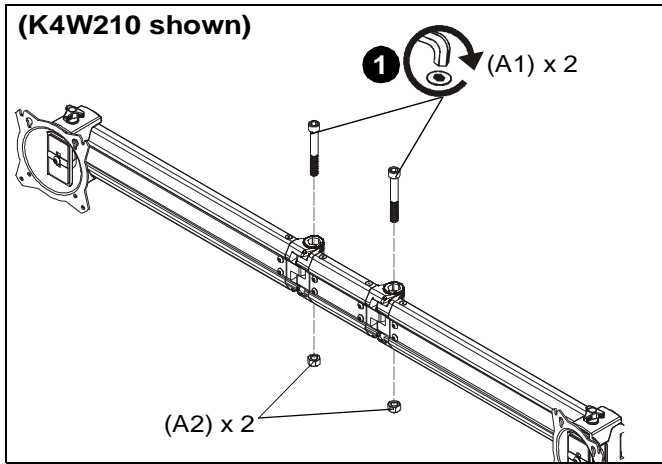

**Figure 5**

2. Hang array center (AA or BB) onto mounting tab on arm assembly (Z) faceplate. (See Figure 6)

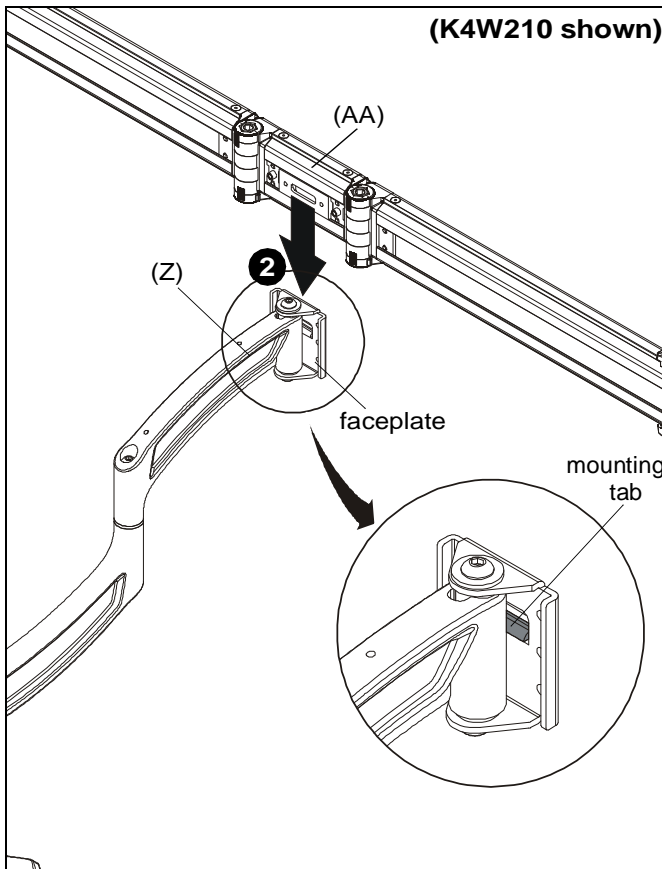

**Figure 6**

3. Use two #10-32 x 3/8" button head cap screws (D2) to secure arm assembly (Z) to array center (AA or BB). (See Figure 7)

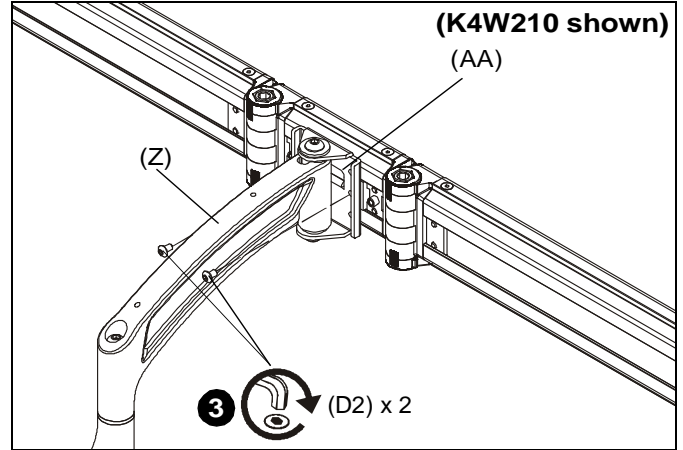

**Figure 7**

4. (K4W310 only) Insert two channel attachments (J) into back of array center (BB). Attachments must be turned horizontally in order to fit into channel. (See Figure 8)

**NOTE:** Channel attachments are already pre-installed on K4W210. Proceed ahead to step 7 if installing K4W210.

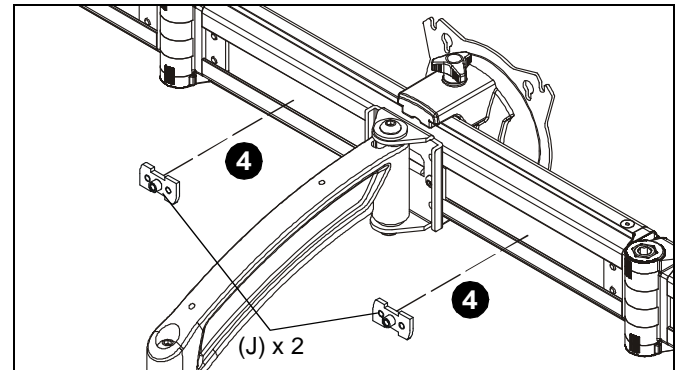

**Figure 8**

5. (K4W310 only) Rotate channel attachments (J) 90° clockwise. (See Figure 9)
6. (K4W310 only) Slide channel attachments (J) toward arm assembly (Z) to prepare for handle installation. (See Figure 9)

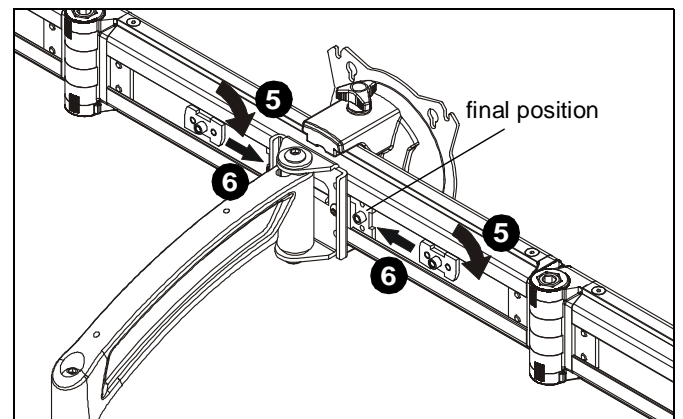

**Figure 9**

- Use two #10-32 x 3/8" Phillips pan machine screws (D1) and two handle clamps (G) to secure handle (H) to array center (AA or BB). (See Figure 10)

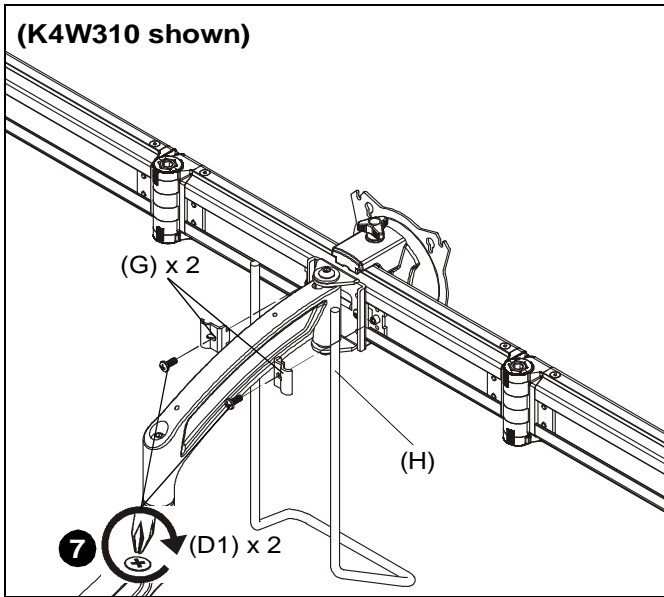

Figure 10

**K4W120 Installation to Arm**

- Use four #10-24 x 1/2" button head cap screws (S) to secure K4W120 head assembly (T) to arm assembly (Z). (See Figure 11)

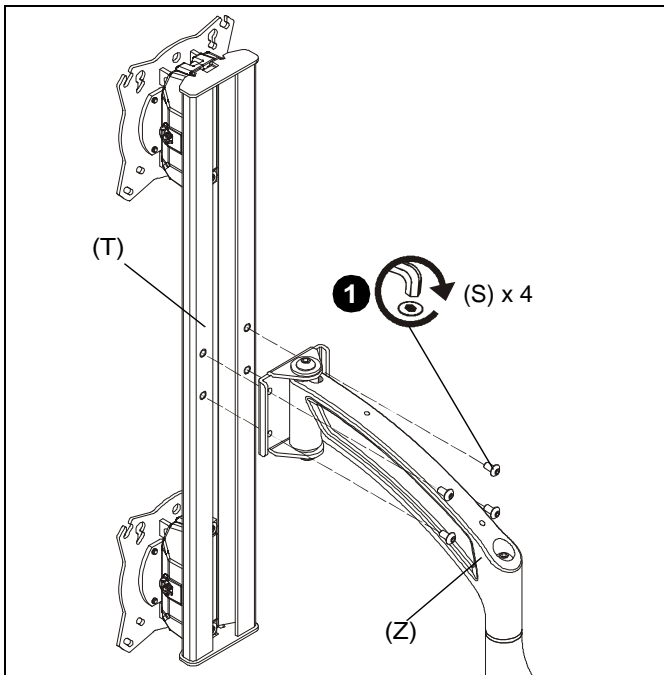

Figure 11

**Display Installation**

**Faceplate Positioning (K4W120 only)**

**IMPORTANT !** : Faceplates should be positioned prior to attaching displays for the K4W120 as the height cannot be adjusted with the displays attached to the faceplates.

- Loosen height adjustment screws for each faceplate to adjust height. (See Figure 12)
- Adjust display to desired height. (See Figure 12)

**IMPORTANT !** : In order to install displays with no gap in between displays, distance between faceplates must equal the height of each display. (See Figure 13)

Faceplates may be positioned a minimum of 12" apart and a maximum of 16" apart. (See Figure 13)

- Tighten height adjustment screws to lock display's position. (See Figure 12)

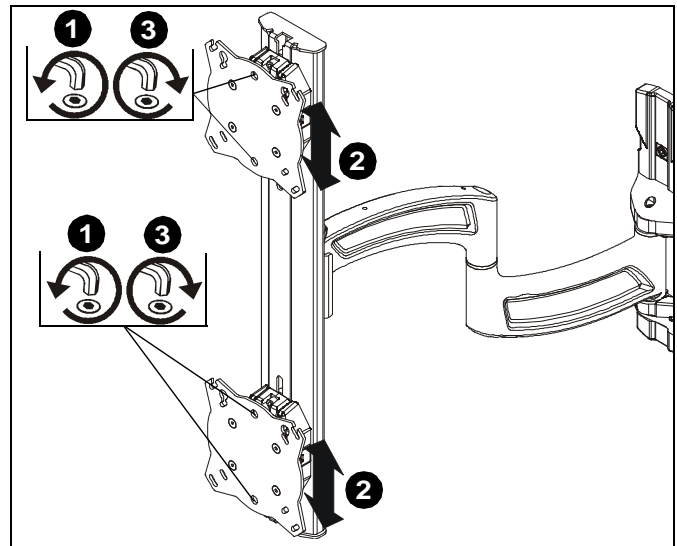

Figure 12

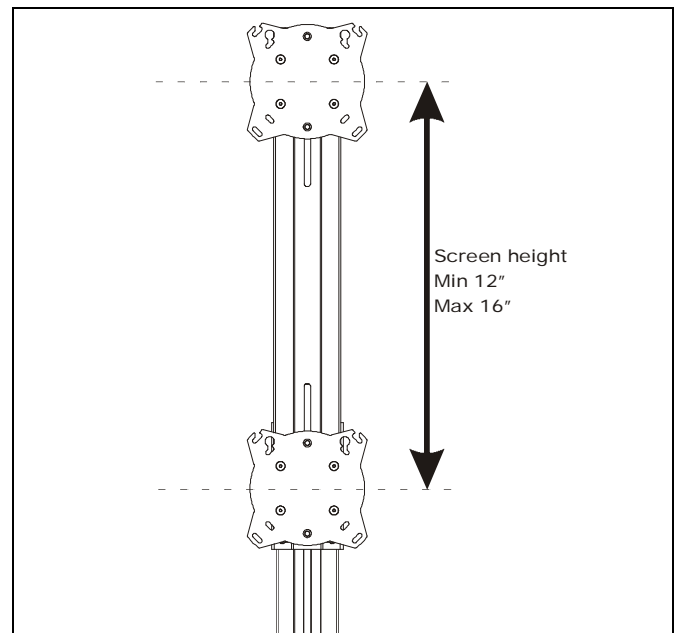

Figure 13

**⚠ WARNING:** Exceeding the weight capacity can result in serious personal injury or damage to equipment! It is the installer's responsibility to make sure the combined weight of all components located on the K4W Series mount up to (and including) the display does not exceed 15 lbs (6.8 kg) per display.

**⚠ CAUTION:** Using screws of improper size may damage your display! Proper screws will easily thread into display mounting holes.

**NOTE:** Supplied screws (M, N and P) may not fit properly for all displays. See display's operating instructions for details.

**Flush Mounting Holes**

**IMPORTANT ! :** For the K4W120, lower display must be installed before installing upper display!

- Using Phillips screwdriver, carefully install two M4 x 12mm Phillips pan machine screws (P) into the *upper* mounting holes on the display. Thread screws completely into display, then back out 3 complete turns. (See Figure 14)

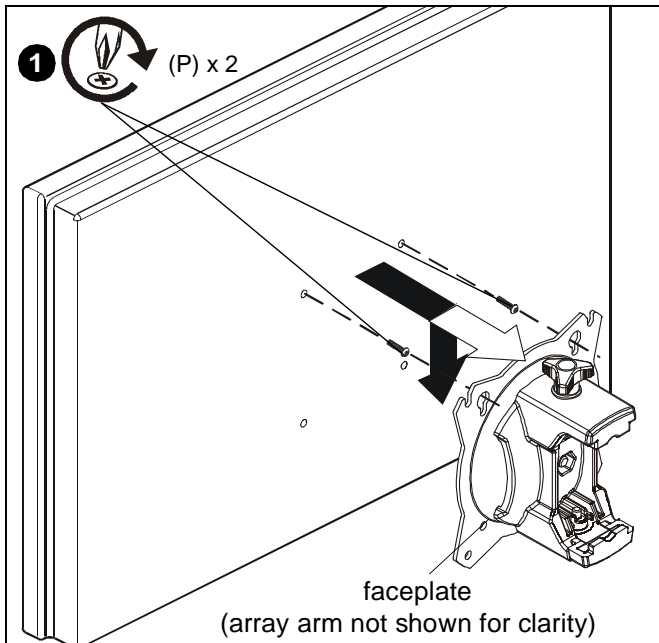

**Figure 14**

- Pick up and align display so that screws (P) (installed on the back of the display in the previous step) fit into the mounting holes on the faceplate. Lower the display firmly into place. (See Figure 14)
- Using Phillips screwdriver, install two M4x12 mm Phillips pan machine screws (P) through the *lower* mounting holes on faceplate into the display. (See Figure 15)

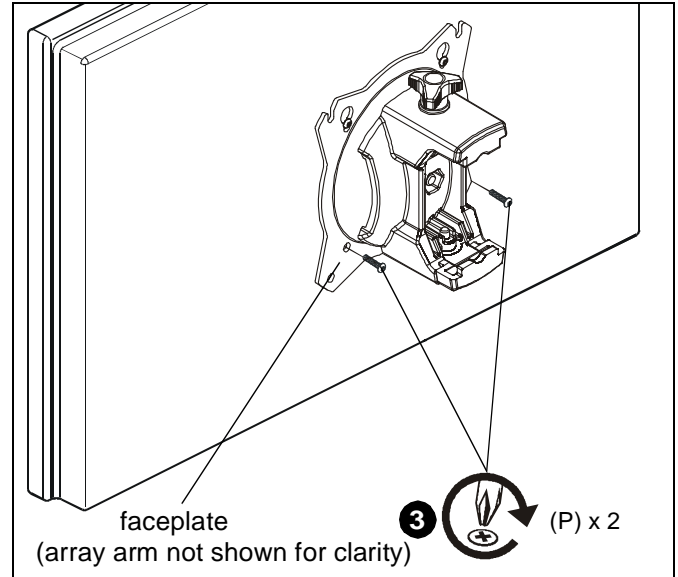

**Figure 15**

- Tighten all four screws (P). Do not over-tighten!

**NOTE:** If roll adjustment is desired for center faceplate, do not tighten screws.

- Repeat Steps 1-4 for other displays.
- Proceed to Wall Cover Installation Section.

**Recessed Mounting Holes**

**IMPORTANT ! :** For the K4W120, lower display must be installed before installing upper display!

**NOTE:** If faceplate does not fit into recessed area of display, proceed with the steps in this section.

- Determine depth of recessed mounting holes relative to back surface of display (against which faceplate will contact).
- Select proper length spacer and screw from table below:

**NOTE:** All spacers used should be the same length. If the recess depths result in multiple spacer lengths, then select the longer spacer.

IF recess DEPTH is:	THEN use spacer:	AND screw:
3/8" or less	Q (3/8" long)	N (M4 x 20mm)
More than 3/8" up to and including 3/4"	R (3/4" long)	M (M4 x 30mm)

**⚠ CAUTION:** Using screws of improper size may damage your display! Proper screws will easily and completely thread into display mounting holes.

- Using Phillips screwdriver, carefully install two selected screws (N or M) through selected spacers (Q or R) into the *upper* mounting holes on the display. Thread screws completely into display, then back out 3 complete turns. (See Figure 16)

- Pick up and align display so that screws (N or M) (installed on the back of the display in the previous step) fit into the mounting holes on the faceplate. Lower the display firmly into place. (See Figure 16)

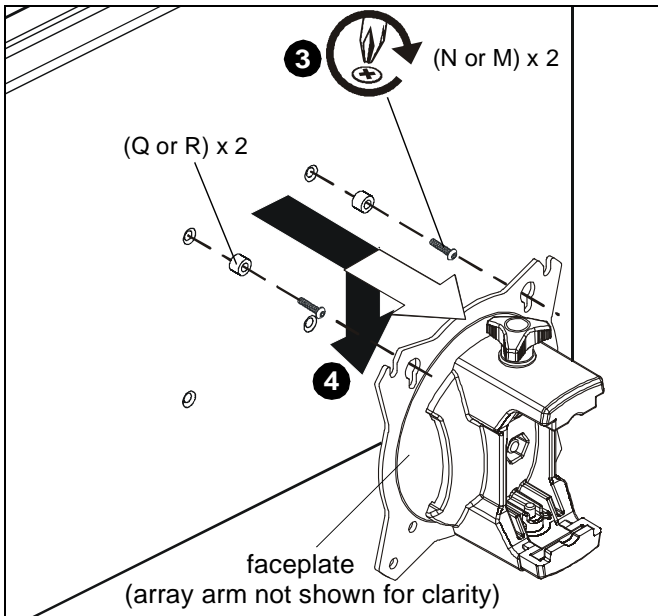

Figure 16

- Slide two remaining selected spacers (Q or R) in between faceplate and display, positioning them over the lower two mounting holes. (See Figure 17)
- Install two remaining selected screws (N or M) through lower two mounting holes on faceplate, selected spacers (Q or R) into the lower mounting holes on the display. (See Figure 17)

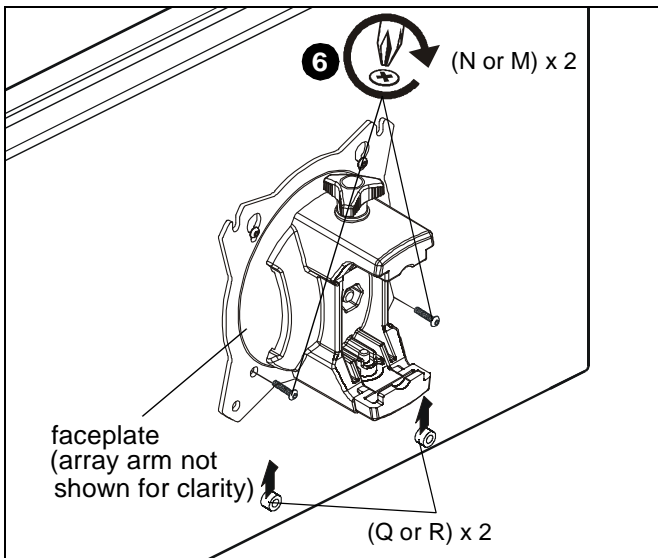

Figure 17

- Tighten all four screws. Do not over-tighten!
- Repeat Steps 3-7 for other displays.

## Wall Cover Installation



**CAUTION:** Wall covers are fragile and may be damaged or broken if installed with excessive force! Use caution when installing and removing wall covers.

- Install top cover (K) onto upper section of wall plate. (See Figure 18)
- Install bottom cover (L) onto lower section of wall plate. (See Figure 18)

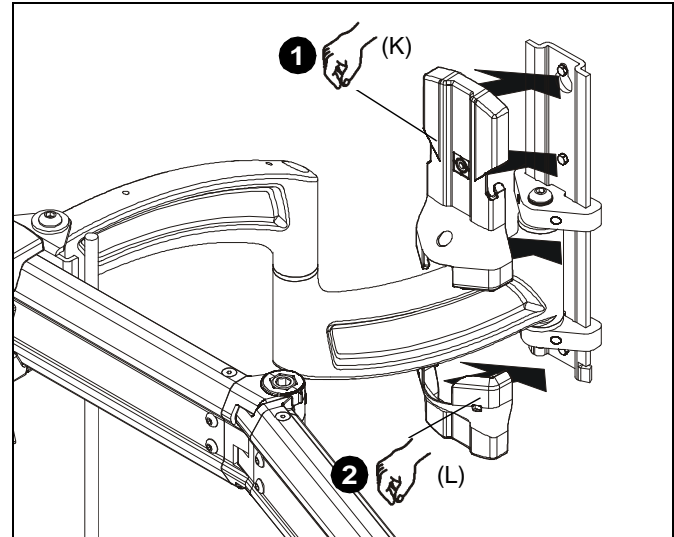

Figure 18

## Adjustments

### Pivot Adjustment (Array Arm) (K4W210/310 only)

- Array arms may pivot toward the front of mount up to 20° per arm. (See Figure 19)
- When arms are at desired pivot position, lock pivot position by tightening 3/8-16 x 2 3/4" socket head carriage screws (A1) using 5/16" hex key (E5). (See Figure 19)

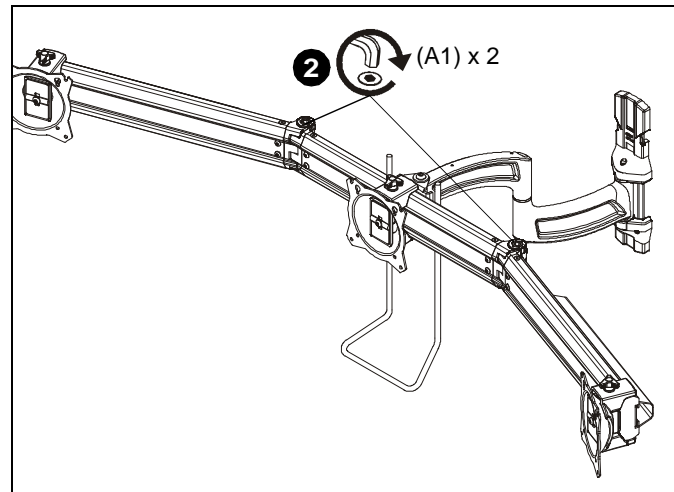

Figure 19

**Pivot Adjustment (Column Arm)**

1. Use handle to extend or collapse column arm (Z) as desired. (See Figure 20)
2. (Optional) Loosen or tighten column arm pivot tension screws as desired to increase or decrease pivot tension. (See Figure 20)

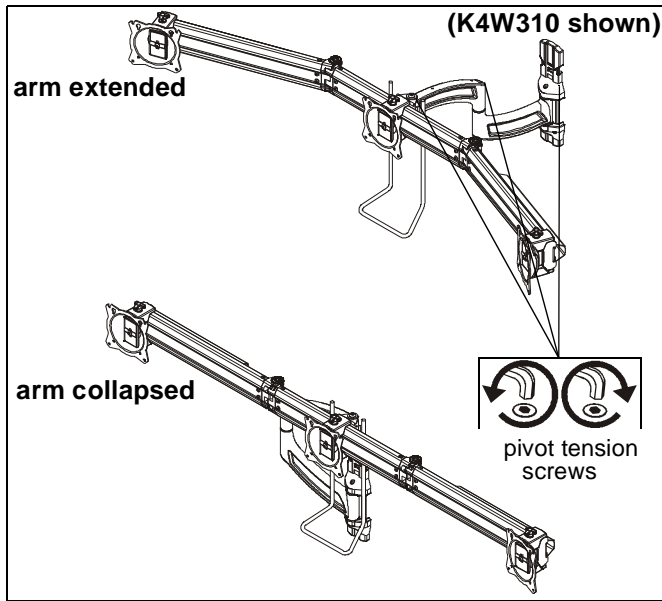

Figure 20

**Mount Height Adjustment**

The TS218SU may be adjusted 1/2" up or down after installation to the wall.

1. Remove display from main assembly.
2. Remove top and bottom covers (K and L) to expose height adjustment screws.
3. Use 1/8" hex key (U) to loosen four height adjustment screws. (See Figure 21)
4. Raise or lower mount until desired height is achieved. (See Figure 21)

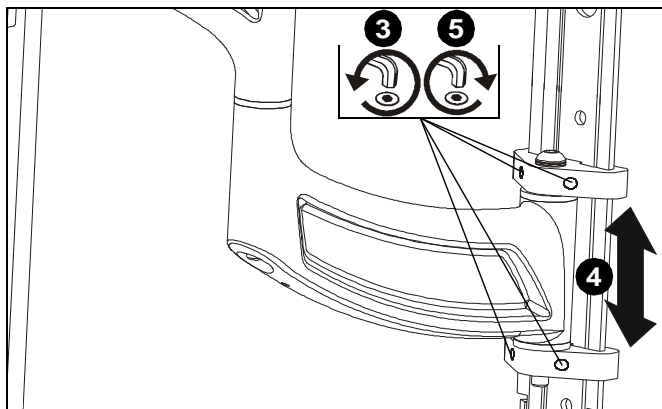

Figure 21

5. Tighten four height adjustment screws. (See Figure 21)
6. Reinstall top and bottom covers (K and L).
7. Reinstall display.

**Display Height Adjustment (K4W120 only)**

**NOTE:** Remove display from faceplate in order to expose height adjustment screws.

1. Loosen height adjustment screws for specific display that will be adjusted. (See Figure 22)
2. Adjust display to desired height. (See Figure 22)
3. Tighten height adjustment screws to lock display's position. (See Figure 22)

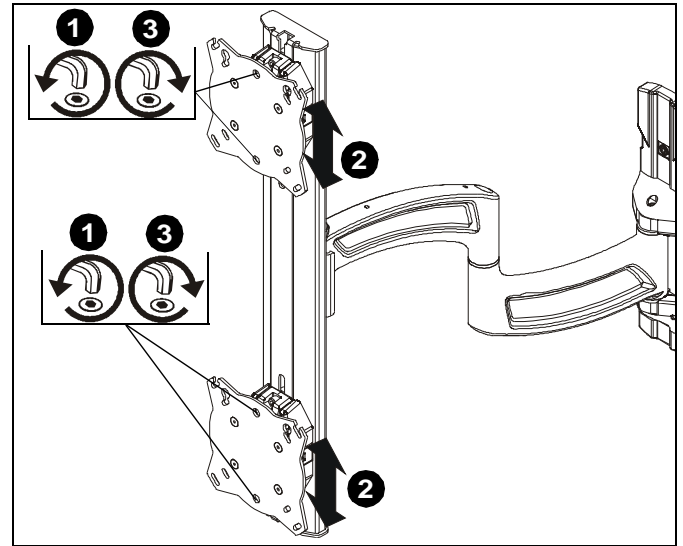

Figure 22

**Faceplate Assembly Removal**

**K4W210/310 Faceplates**

1. Remove hex head bolt from bottom of faceplate assembly. (See Figure 23)
2. Slide out removable plate from bottom of faceplate assembly. (See Figure 23)

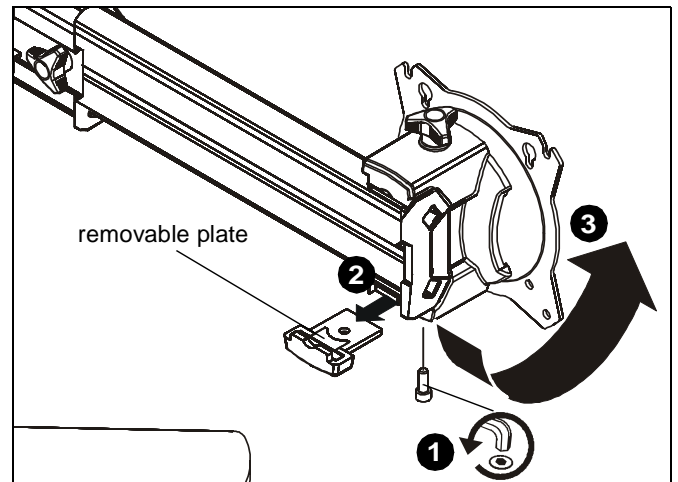

Figure 23

3. Remove faceplate assembly from array arm. (See Figure 23)

**To Reattach Faceplate Assembly**

- Place faceplate assembly on array arm at desired mounting position. (See Figure 24)
- Slide removable plate back into slot at bottom of faceplate assembly. (See Figure 24)
- Reinstall hex head bolt removed in Step 1 to secure faceplate assembly to array arm. (See Figure 24)

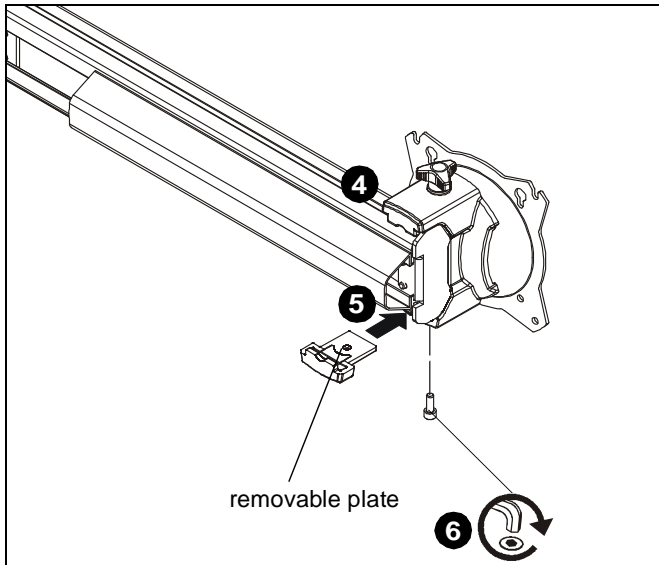

Figure 24

**Pitch/Roll/Yaw Adjustment****K4W210/310 Faceplates**

- Loosen knob on top of faceplate assembly. (See Figure 25)
- Adjust pitch, roll and/or yaw as desired. (See Figure 25)
- Tighten knob to secure desired faceplate position. (See Figure 25)

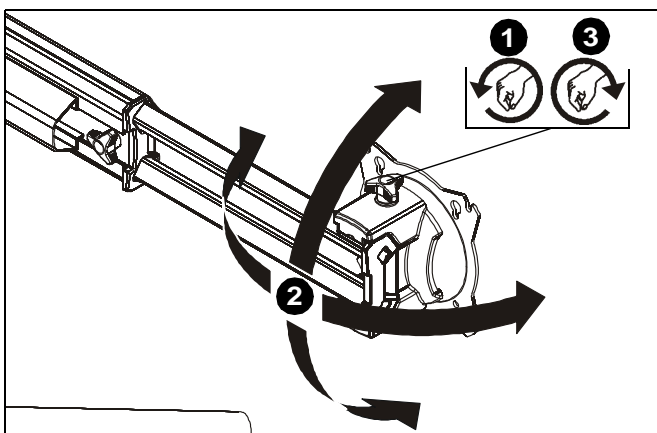

Figure 25

**K4W120 Faceplate(s)****Pitch**

- Loosen knob on side of center faceplate assembly. (See Figure 26)
- Adjust pitch as desired. (See Figure 26)
- Tighten knob to secure desired pitch position. (See Figure 26)

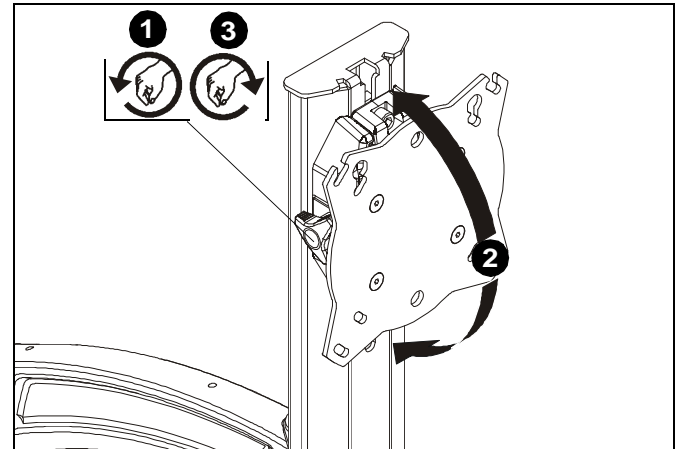

Figure 26

**Roll**

- Loosen screws holding display to faceplate slightly.
- Adjust roll position as the mounting holes on faceplate allow.
- Tighten screws to lock roll position.

**Lateral Shift (K4W210/310 only)**

- Loosen knob on top of faceplate assembly until faceplate can slide freely along array. (See Figure 27)
- Adjust lateral position as desired. (See Figure 27)
- Tighten knob to secure lateral position. (See Figure 27)

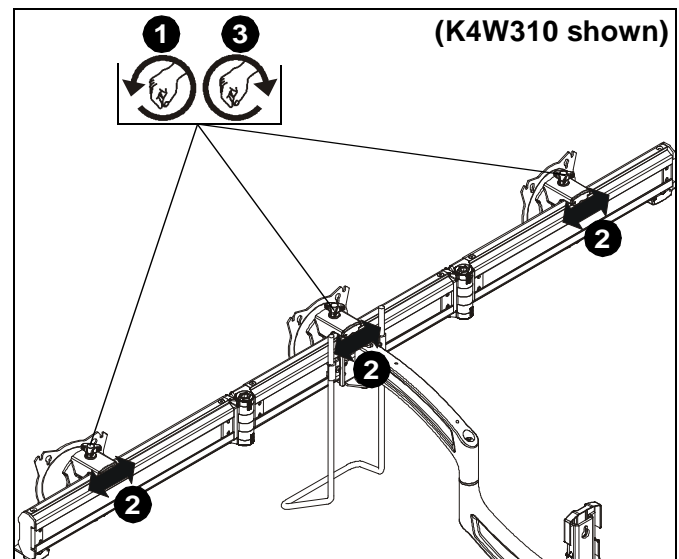

Figure 27

**Cable Management - Covers (K4W210/310 only)**

1. Route cables from display through cable management covers (V) as desired. (See Figure 28)
2. Install cable management covers (V) onto array arms (X and Y). (See Figure 28)

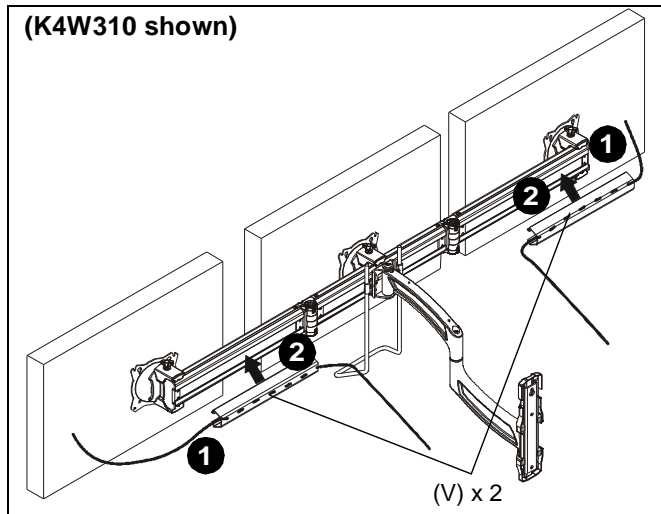

Figure 28

**Cable Management - Clips**

1. Use two #10-24 x 3/8" button head cap screws (E2) to attach two tie mounts (E1) to upper mounting arm. (See Figure 29)
2. Use two #10-24 x 3/8" button head cap screws (E2) to attach two tie mounts (E1) to lower mounting arm. (See Figure 29)

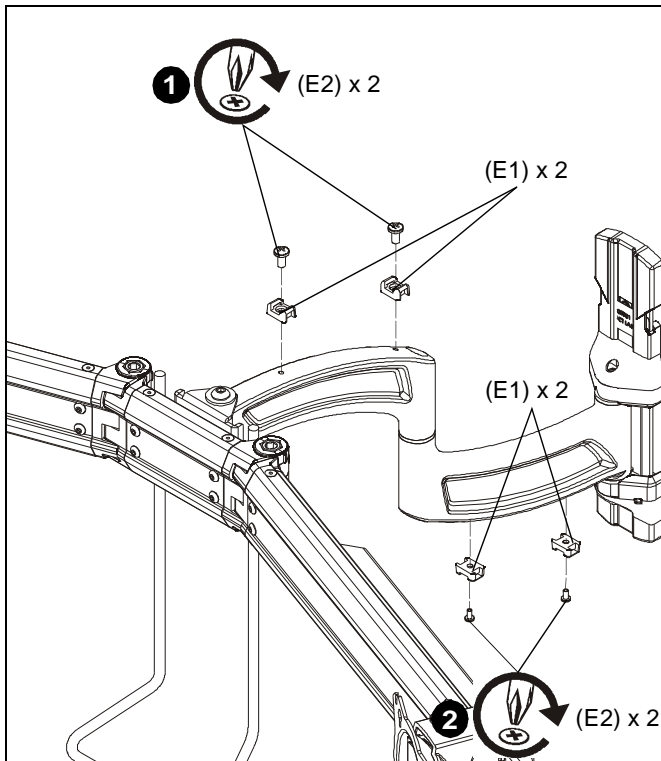

Figure 29

3. Route cables along mounting arms. (See Figure 30)
4. Use cable ties (not included) to secure cables to tie clips (E1). (See Figure 30)

**NOTE:** Leave enough slack in the cables so that arm may still swing without resistance from the cables.

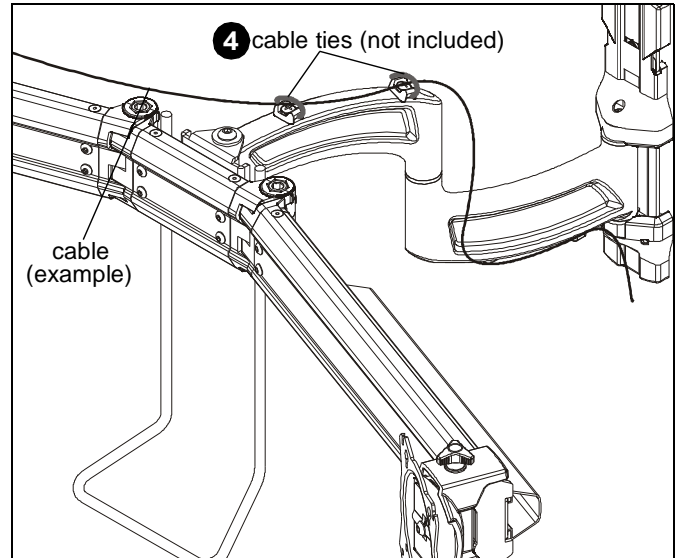

Figure 30



Our Mounts. **Your Vision.**

Chief, a products division of  
Milestone AV Technologies

8800-002326 Rev03  
©2014 Milestone AV Technologies  
[www.chiefmfg.com](http://www.chiefmfg.com)  
04/14

<b>USA/International</b>	<b>A</b> 6436 City West Parkway, Eden Prairie, MN 55344
	<b>P</b> 800.582.6480 / 952.225.6000
	<b>F</b> 877.894.6918 / 952.894.6918
<b>Europe</b>	<b>A</b> Franklinstraat 14, 6003 DK Weert, Netherlands
	<b>P</b> +31 (0) 495 580 852
	<b>F</b> +31 (0) 495 580 845
<b>Asia Pacific</b>	<b>A</b> Office No. 1 on 12/F, Shatin Galleria 18-24 Shan Mei Street Fotan, Shatin, Hong Kong
	<b>P</b> 852 2145 4099
	<b>F</b> 852 2145 4477

