

---

# INSTALLATION INSTRUCTIONS

---

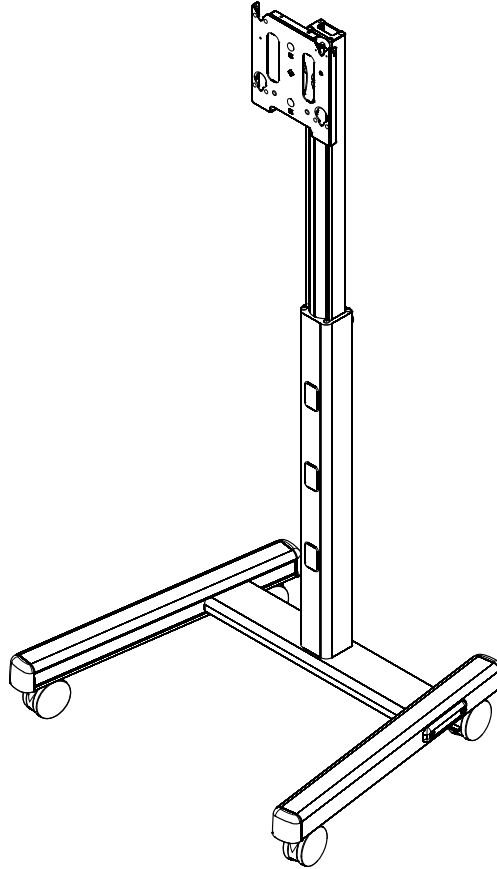

---

**Display Carts**

---

## DISCLAIMER

Milestone AV Technologies and its affiliated corporations and subsidiaries (collectively, "Milestone"), intend to make this manual accurate and complete. However, Milestone makes no claim that the information contained herein covers all details, conditions or variations, nor does it provide for every possible contingency in connection with the installation or use of this product. The information contained in this document is subject to change without notice or obligation of any kind. Milestone makes no representation of warranty, expressed or implied, regarding the information contained herein. Milestone assumes no responsibility for accuracy, completeness or sufficiency of the information contained in this document.

Chief® and ClickConnect™ are registered trademarks of Milestone AV Technologies. All rights reserved.

## IMPORTANT SAFETY INSTRUCTIONS

 **WARNING:** A WARNING alerts you to the possibility of serious injury or death if you do not follow the instructions.

 **CAUTION:** A CAUTION alerts you to the possibility of damage or destruction of equipment if you do not follow the corresponding instructions.

 **WARNING:** Failure to read, thoroughly understand, and follow all instructions can result in serious personal injury, damage to equipment, or voiding of factory warranty! It is the installer's responsibility to make sure all components are properly assembled and installed using the instructions provided.

 **WARNING:** Failure to provide adequate structural strength for this component can result in serious personal injury or damage to equipment! It is the installer's responsibility to make sure the structure to which this component is attached can support five times the combined weight of all equipment. Reinforce the structure as required before installing the component.

 **WARNING:** Exceeding the weight capacity can result in serious personal injury or damage to equipment! It is the installer's responsibility to make sure the combined weight of all components located between the MFC Series cart up to (and including) the display does not exceed 125 lbs (56.70 kg) for the MFC Series. Use with heavier televisions may result in instability causing tip over resulting in death or serious injury!

 **WARNING:** Use this mounting system only for its intended use as described in these instructions. Do not use attachments not recommended by the manufacturer.

 **WARNING:** Never operate this mounting system if it is damaged. Return the mounting system to a service center for examination and repair.

 **WARNING:** Do not use this product outdoors.

 **WARNING:** RISK OF INJURY TO PERSONS! Do not place video equipment such as televisions or computer monitors on cart legs.

 **WARNING:** RISK OF SERIOUS INJURY OR DEATH! Placing a remote control or toy on the cart may encourage a child to climb onto the cart causing the cart to tip over onto the child. DO NOT place remote controls or toys on the cart!

 **WARNING:** RISK OF SERIOUS INJURY OR DEATH! Relocating audio and/or video equipment to the cart may result in the cart collapsing or overturning onto a child. DO NOT relocate audio and/or video equipment to the cart!

**NOTE:** The MFC Series cart has no user serviceable parts.

**NOTE:** The MFC Series cart can support screen sizes up to a maximum of 55" wide.

**NOTE:** The MFC Series includes:

- Model MFCU which includes the Listed Chief accessory MSBU interface bracket;
- Accessory Model MFC6000 (to be used with Listed Chief accessory MSBU interface bracket--not included)

**--SAVE THESE INSTRUCTIONS--**

**DIMENSIONS**

PRODUCT FEATURES	
WEIGHT CAPACITY	125 LBS
HEIGHT ADJUSTMENT (GROUND TO MIDDLE OF SCREEN)	48" TO 72" IN 2" INCREMENTS
TILT / ROLL / YAW	±15° / ±0° / ±0°

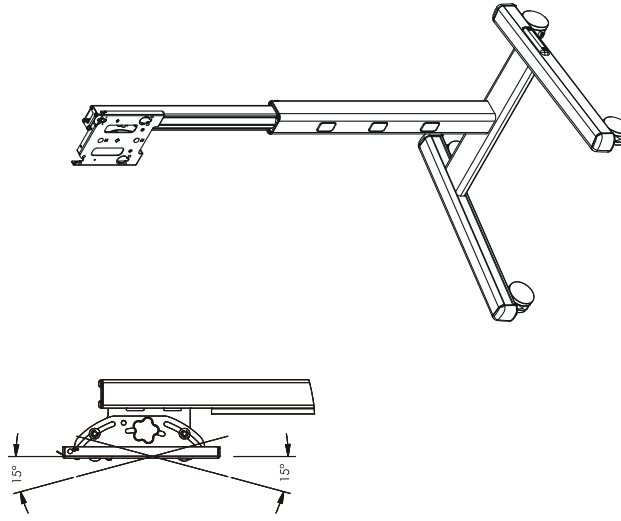



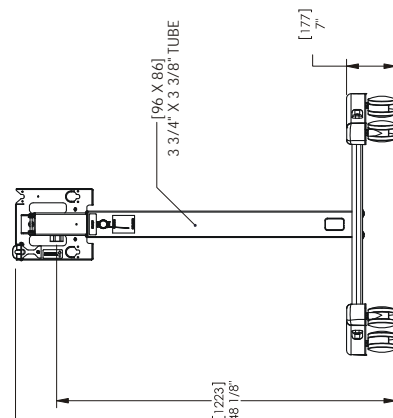
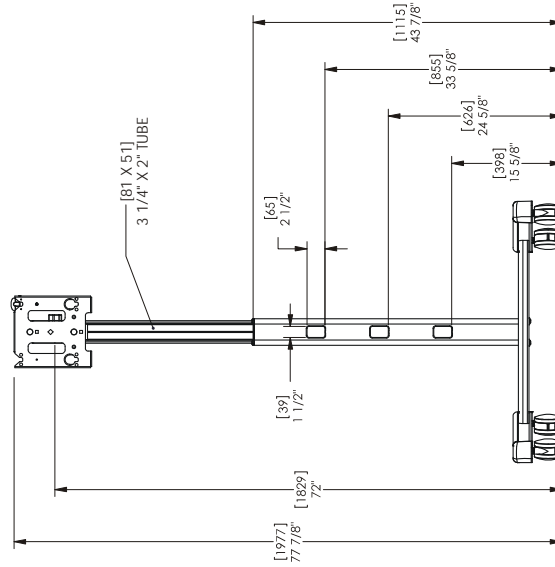
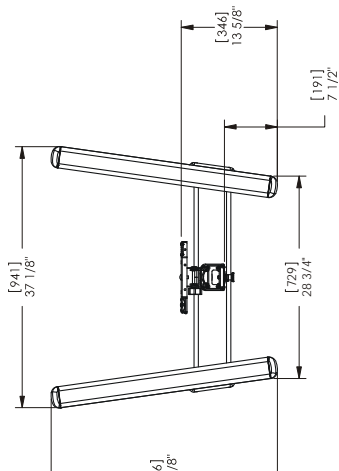





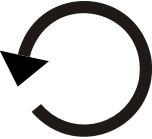

NOTE: CUSTOM INTERFACE BRACKET NOT SHOWN. THE CUSTOM INTERFACE BRACKET NEEDED FOR YOUR DISPLAY WILL ADD BETWEEN 1/2" AND 2" IN DEPTH AND MAY AFFECT LOCATION OF DISPLAY ON THE MOUNT.  
SEE MSBU DRAWING ALSO.

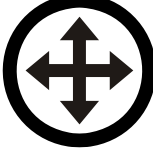

DIMENSIONS: [MILLIMETERS]  
INCHES

**LEGEND**

	<p><b>Tighten Fastener</b></p> <p>Apretar elemento de fijación</p> <p>Befestigungsteil festziehen</p> <p>Apertar fixador</p> <p>Serrare il fissaggio</p> <p>Bevestiging vastdraaien</p> <p>Serrez les fixations</p>		<p><b>Pencil Mark</b></p> <p>Marcar con lápiz</p> <p>Stiftmarkierung</p> <p>Marcar com lápis</p> <p>Segno a matita</p> <p>Potloodmerkteken</p> <p>Marquage au crayon</p>
	<p><b>Loosen Fastener</b></p> <p>Aflojar elemento de fijación</p> <p>Befestigungsteil lösen</p> <p>Desapertar fixador</p> <p>Allentare il fissaggio</p> <p>Bevestiging losdraaien</p> <p>Desserrez les fixations</p>		<p><b>Drill Hole</b></p> <p>Perforar</p> <p>Bohrloch</p> <p>Fazer furo</p> <p>Praticare un foro</p> <p>Gat boren</p> <p>Percez un trou</p>
	<p><b>Phillips Screwdriver</b></p> <p>Destornillador Phillips</p> <p>Kreuzschlitzschraubendreher</p> <p>Chave de fendas Phillips</p> <p>Cacciavite a stella</p> <p>Kruiskopschroevendraaier</p> <p>Tournevis à pointe cruciforme</p>		<p><b>Adjust</b></p> <p>Ajustar</p> <p>Einstellen</p> <p>Ajustar</p> <p>Regolare</p> <p>Afstellen</p> <p>Ajuster</p>
	<p><b>Open-Ended Wrench</b></p> <p>Llave de boca</p> <p>Gabelschlüssel</p> <p>Chave de bocas</p> <p>Chiave a punte aperte</p> <p>Steeksleutel</p> <p>Clé à fourche</p>		<p><b>Remove</b></p> <p>Quitar</p> <p>Entfernen</p> <p>Remover</p> <p>Rimuovere</p> <p>Verwijderen</p> <p>Retirez</p>
	<p><b>By Hand</b></p> <p>A mano</p> <p>Von Hand</p> <p>Com a mão</p> <p>A mano</p> <p>Met de hand</p> <p>À la main</p>		<p><b>Optional</b></p> <p>Opcional</p> <p>Optional</p> <p>Opcional</p> <p>Opzionale</p> <p>Optie</p> <p>En option</p>
	<p><b>Hex-Head Wrench</b></p> <p>Llave de cabeza hexagonal</p> <p>Sechskantschlüssel</p> <p>Chave de cabeça sextavada</p> <p>Chiave esagonale</p> <p>Zeskantsleutel</p> <p>Clé à tête hexagonale</p>		<p><b>Security Wrench</b></p> <p>Llave de seguridad</p> <p>Sicherheitsschlüssel</p> <p>Chave de segurança</p> <p>Chiave di sicurezza</p> <p>Veiligheidsleutel</p> <p>Clé de sécurité</p>

**TOOLS REQUIRED FOR INSTALLATION**

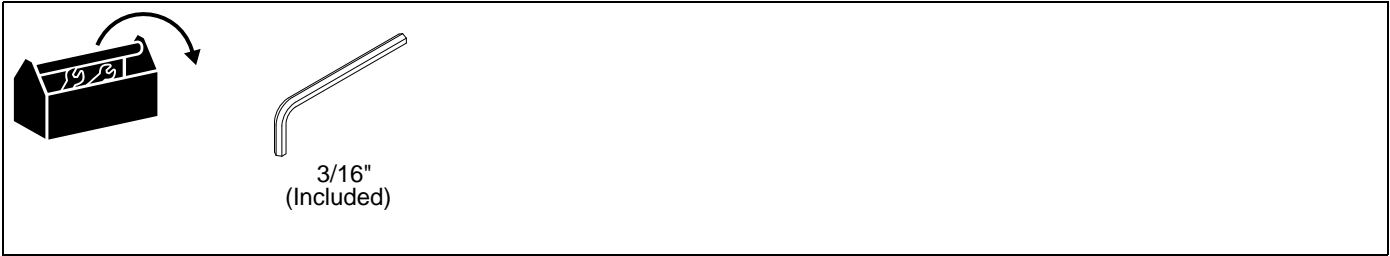

**PARTS**

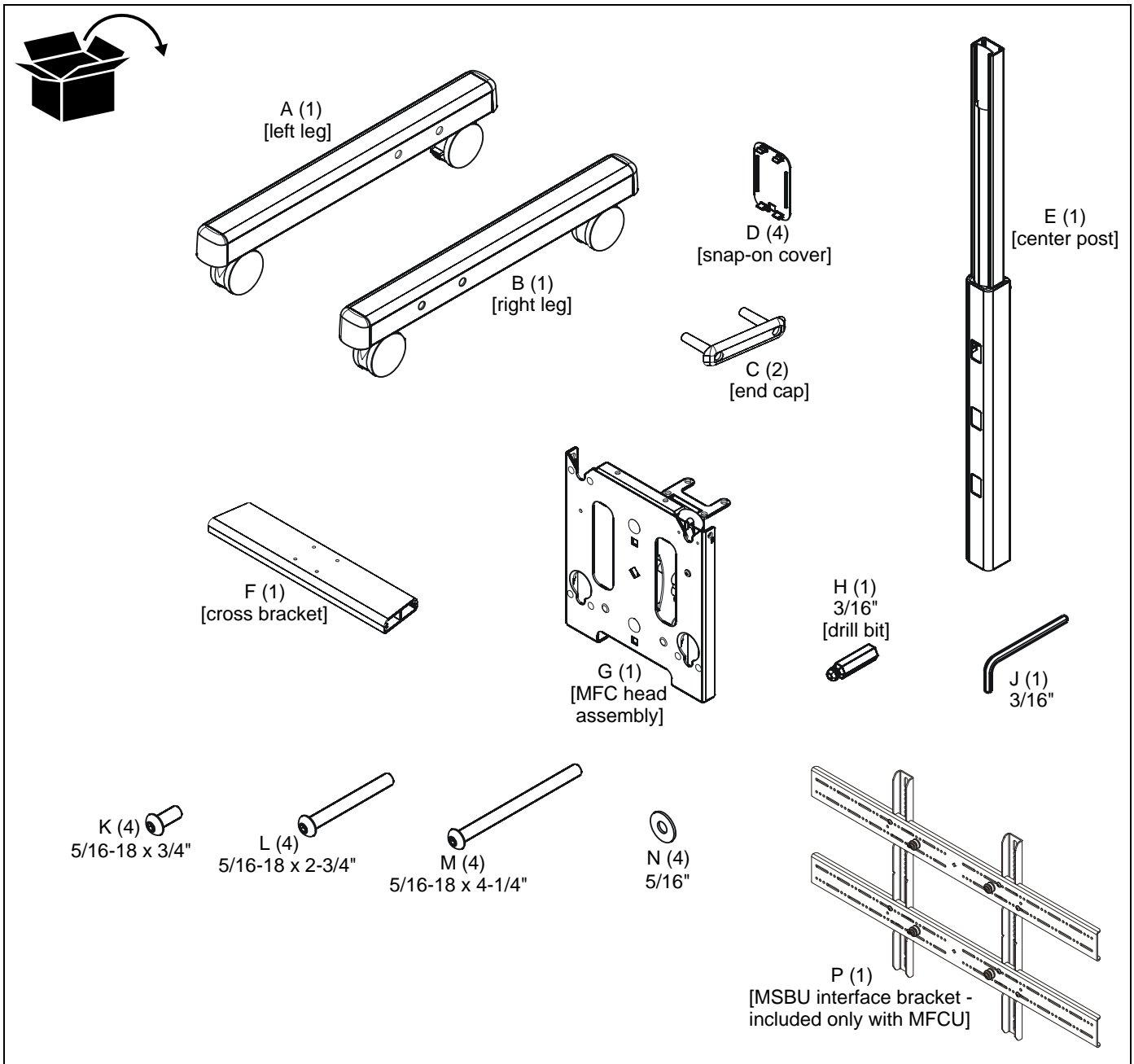

**ASSEMBLY**



**CAUTION:** Attachment holes may be damaged if a power drill is used to insert button head cap screws. Screws should first be inserted and turned **BY HAND** with the hex key or with a hand held screwdriver **BEFORE** using the hex head drill bit (J) and power drill to complete the attachment.

**Assembling Cart**

1. Assemble two legs (A) and (B) to the cart cross bracket (F) using two 5/16-18 x 4-1/4" button head cap screws (M) through one end cap (C) per leg. (See Figure 1)

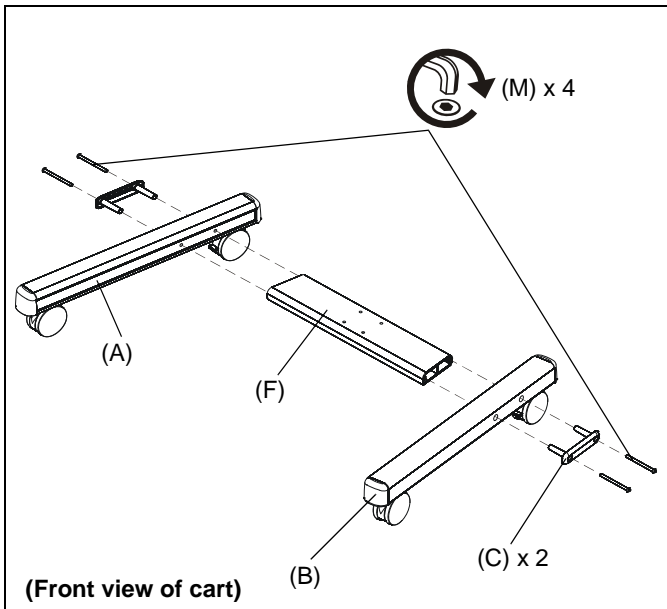

**Figure 1**



**CAUTION:** INNER COLUMN IS SHIPPED DISENGAGED and may pinch hands! Hold both inner and outer posts (columns) while removing from box.

**IMPORTANT ! :** Press cable tie tab to loosen and remove cable tie from around knob post. (See Figure 2)

**NOTE:** Disengage knob on center post **BEFORE** attaching base to the center post.

2. Lift up slightly on the inner column of center post and hold firmly toward top of post. (See Figure 2)
3. Pull out knob on the center post and turn 90° in either direction to disengage the locking mechanism. (See Figure 2)
4. Raise the inner column and turn the knob 90° in either direction to engage the knob and lock the column in place. (See Figure 2)

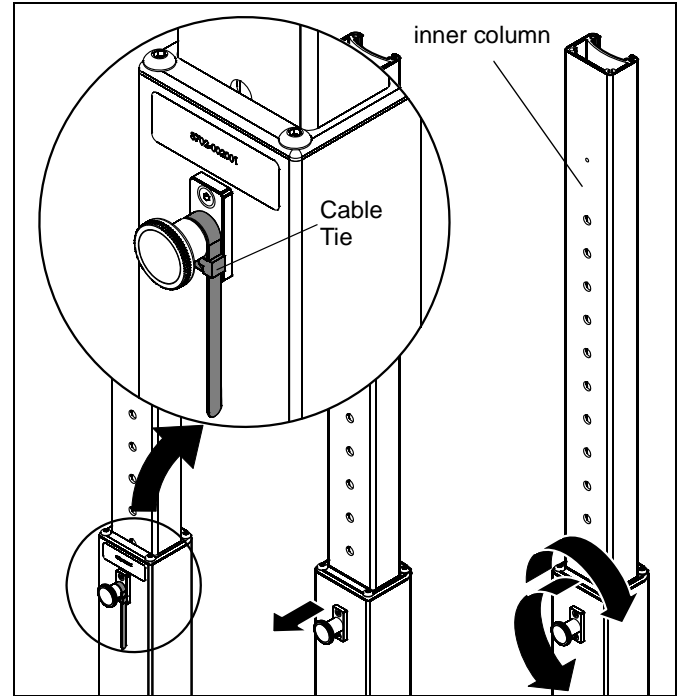

**Figure 2**

**NOTE:** Insert and turn screws in order shown (1, 2, 3, 4) in Figure 3.

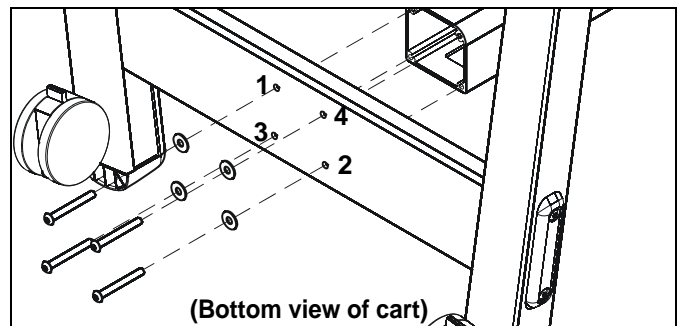

**Figure 3**

5. Attach center post (E) to leg assembly using four 5/16-18 x 2-3/4" button head cap screws (L) and four 5/16" washers (N). (See Figure 3) and (See Figure 4)

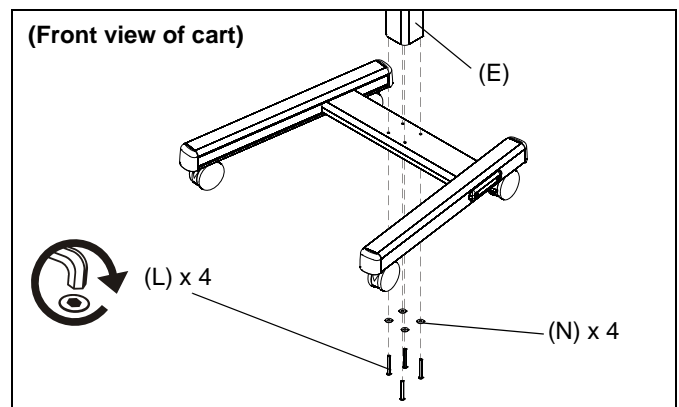

**Figure 4**

**IMPORTANT !** : When attaching head assembly ensure that the ClickConnect lock is at TOP of head assembly, and bracket tabs slide into the stand assembly. (See Figure 5)

1. Slide head assembly (G) into the stand assembly. (See Figure 5)
2. Attach head assembly (G) to the cart assembly using four 5/16-18 x 3/4" button head cap screws (K). (See Figure 5)

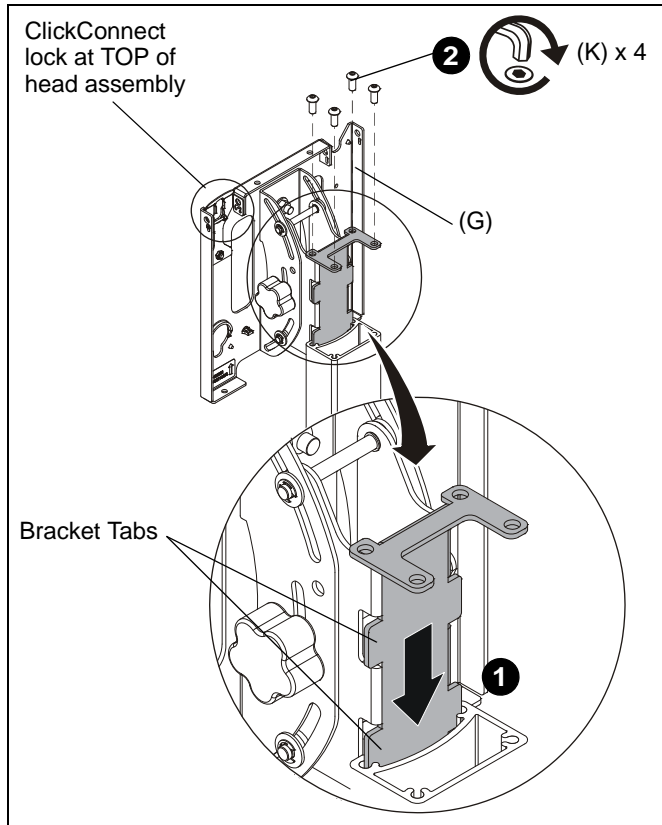

Figure 5

**Adjusting Cart Height**



**CAUTION:** ALWAYS remove the display(s) BEFORE adjusting the height of cart.

1. Firmly grasp head assembly. (See Figure 6)

**IMPORTANT !** : To avoid pinching hands, hold head assembly when adjusting cart height.

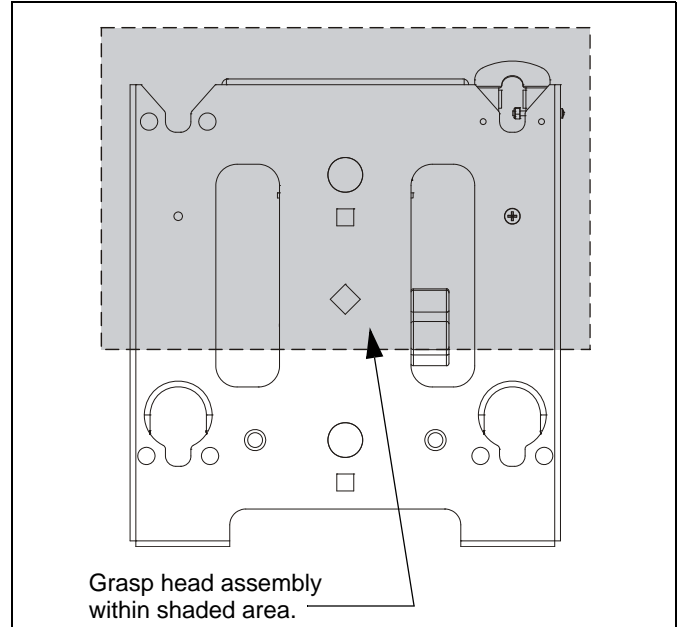

Figure 6

2. Adjust the cart to the desired height by slightly lifting the head assembly, pulling out knob on the center post and turning 90° in either direction to disengage the locking mechanism. (See Figure 7)
3. Raise or lower the center post, then turn the knob 90° either direction to engage the knob and lock the cart at desired height. (See Figure 7)

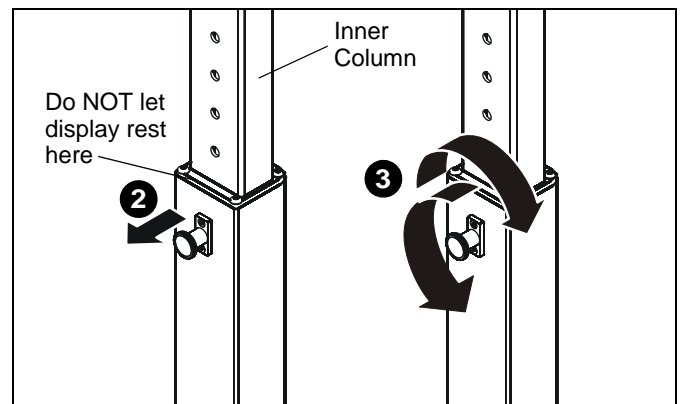

Figure 7

**IMPORTANT !** : Set the height of the cart so the display does NOT rest on the lower part of the center post. (See Figure 7) Always set the height so the knob is engaged in a hole in the center post.

### Attaching Display to Cart



**WARNING:** Exceeding the weight capacity can result in serious personal injury or damage to equipment! It is the installer's responsibility to make sure the combined weight of all components located between the MFC Series cart up to (and including) the display does not exceed 125 lbs (56.70 kg) for the MFC Series. Use with heavier televisions may result in instability causing tip over resulting in death or serious injury!



**CAUTION:** Before attaching display to cart set the brakes on the back wheels by pressing down on the tab. (See Figure 8)

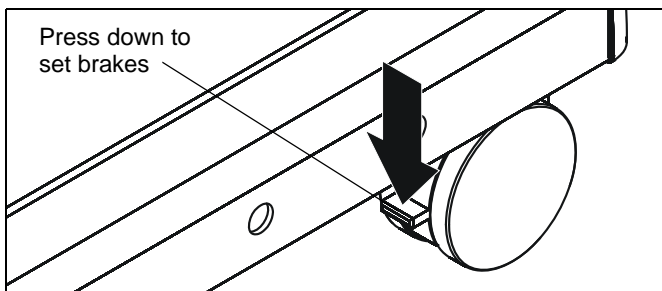

Figure 8

1. Attach MSBU interface bracket to the display following the instructions included with the MSBU interface bracket.
2. While supporting both sides of display, align four mounting buttons on interface bracket with four mounting holes in head assembly. (See Figure 9) and (See Figure 10)

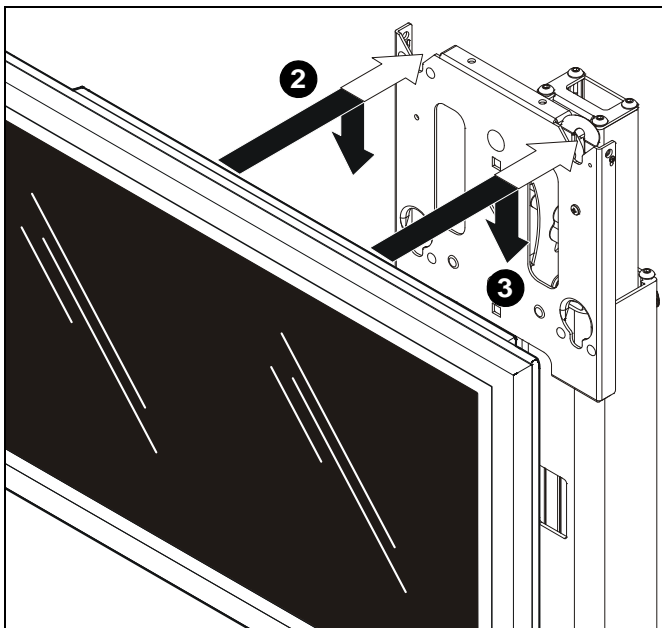

Figure 9



**WARNING:** Display may be very heavy! Ensure display may be safely lifted and maneuvered as required to install on cart. Failure to take adequate precautions may result in serious personal injury or damage to equipment!

3. Lower display into place listening for audible "click" to ensure recessed area of mounting buttons are properly seated in lower area of mounting holes. (See Figure 9) and (See Figure 10)



**WARNING:** IMPROPER INSTALLATION CAN LEAD TO CART OR DISPLAY FALLING CAUSING SERIOUS PERSONAL INJURY OR DAMAGE TO EQUIPMENT! Ensure mounting buttons are completely engaged in mounting holes.

**NOTE:** Holes are provided in the faceplate for use with a padlock or similar locking device, if desired. In addition, the pin and nut may be removed from the upper holes and moved to the lower holes for use as a more permanent locking device. (See Figure 10)

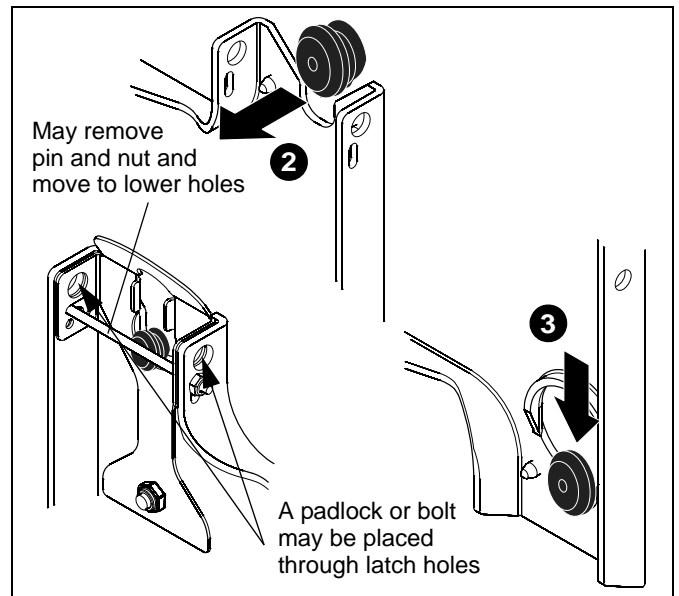

Figure 10



## Tilting Display

The display can be tilted up to 15° either backward or forward from a straight upright position.

1. Turn knob counterclockwise on back of head assembly to loosen the tilt. (See Figure 11)

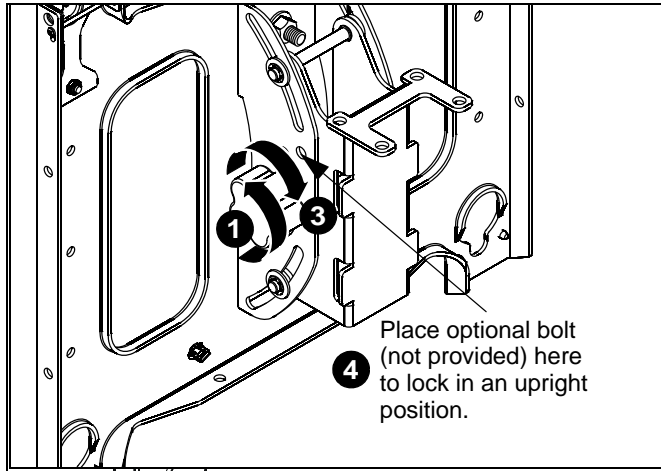

Figure 11

2. Tilt display as desired, to a maximum of 15° either forward or backward.
3. Turn knob clockwise to tighten display on head assembly. (See Figure 11)



**CAUTION:** Tighten knob on back of head assembly to prevent damage when moving the cart and display.

4. If leaving the display in a straight upright position, it is recommended that a bolt (not provided) be placed through the head assembly (See Figure 11) to lock the display into the upright position.

## Cable Management

1. Signal cables can be run down the front flap of the center post and out the front of the post at any of the openings. (See Figure 12)
2. The display power cord can be run through the top and down through the post to exit out the back. (See Figure 12)
3. Any accessory power cords can be run through the front and down through the post to exit out the back. (See Figure 12)
4. Install the snap-on covers (D) to any opening that is not being used. (See Figure 12)
5. To remove the snap-on covers, grip the sides of the cover in the middle and pull off. They can also be removed by inserting a flat-blade screwdriver into the bottom slot and rotating the screwdriver.

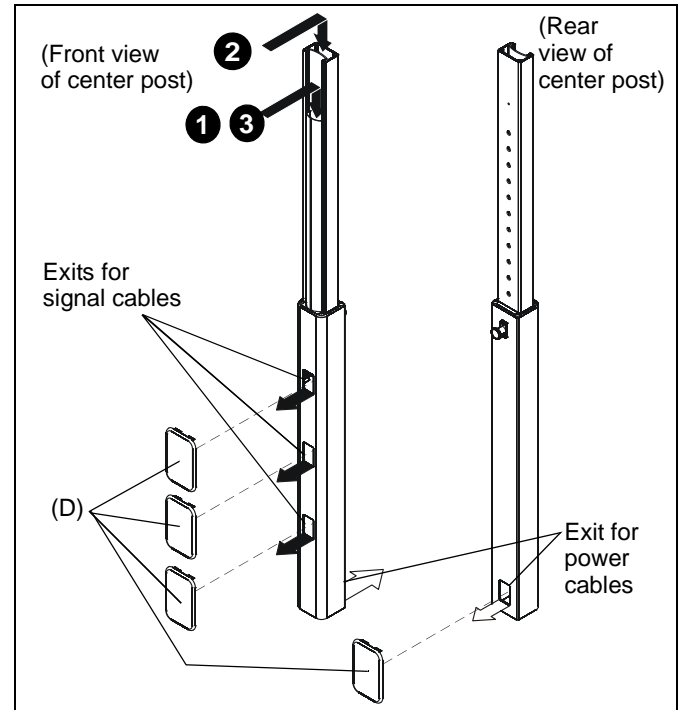

Figure 12

## Cart Use and Maintenance



**WARNING:** Exceeding the weight capacity can result in serious personal injury or damage to equipment! It is the installer's responsibility to make sure the combined weight of all components located between the MFC Series cart up to (and including) the display does not exceed 125 lbs (56.70 kg) for the MFC Series. Use with heavier televisions may result in instability causing tip over resulting in death or serious injury!



**WARNING: RISK OF SERIOUS INJURY OR DEATH!** Placing a remote control or toy on the cart may encourage a child to climb onto the cart causing the cart to tip over onto the child. **DO NOT** place remote controls or toys on the cart!



**WARNING: RISK OF SERIOUS INJURY OR DEATH!** Relocating audio and/or video equipment to the cart may result in the cart collapsing or overturning onto a child. **DO NOT** relocate audio and/or video equipment to the cart!



**WARNING: CART CAN TIP OVER RESULTING IN RISK OF INJURY!** Do not allow children under 16 to move cart. Only adults should move this cart. Move cart slowly. Apply moving force on narrow dimension. Never apply force at top - always push near middle. Push, don't pull cart. (See Figure 13)

**NOTE:** The MFC Series cart has no user serviceable parts.

**NOTE:** The MFC Series cart can support screen sizes up to a maximum of 55" wide.

1. Always place cart on level surface.
2. Always lock the wheels when the cart is not moving.
3. Check and tighten the hex nuts on the casters occasionally. (See Figure 14) These should be checked especially after use on uneven ground.

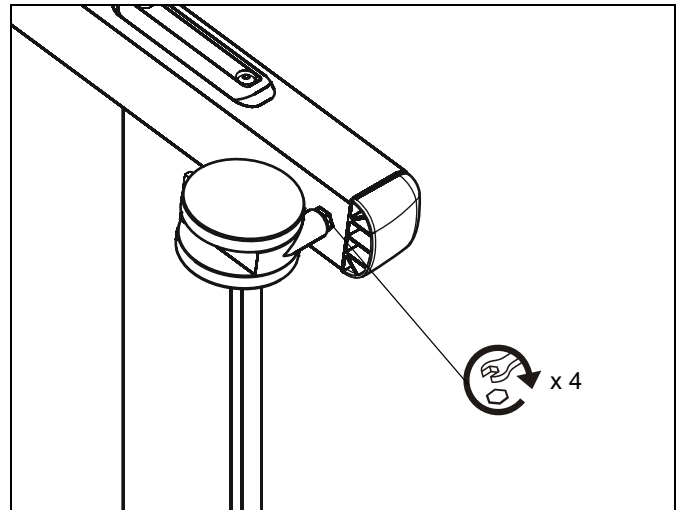

Figure 14

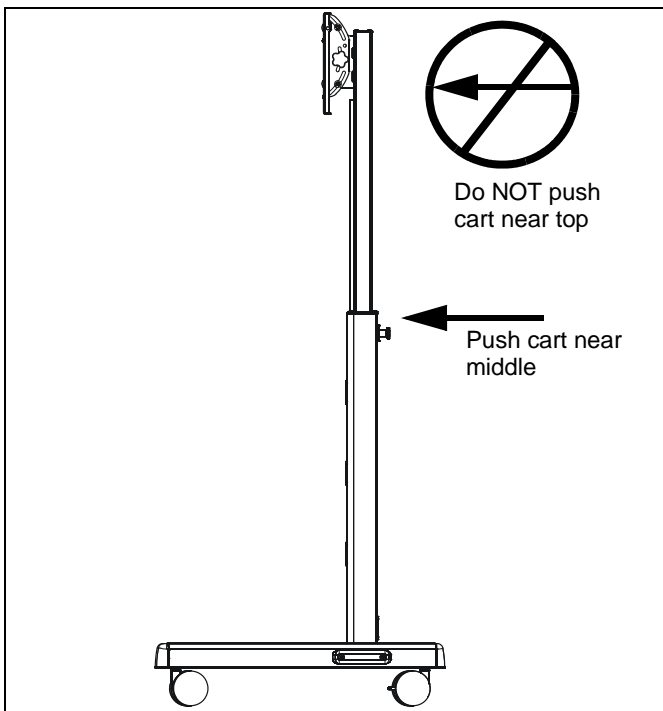

Figure 13

## Removing Display from Cart

1. Remove bolt or padlock from faceplate (if used). (See Figure 15)

**NOTE:** The pin may have been used as a more permanent locking device. If so, remove nut and pin and move from the lower holes to the upper holes.

2. Pull back on flag on upper mounting hole and press pin down into "Open" position. (See Figure 15)



**WARNING:** EACH DISPLAY MAY WEIGH IN EXCESS OF 40 LBS! Always use two people and proper lifting techniques when installing or positioning display on stand.

3. Carefully lift display from cart.
4. Lift up on pin and place flag back against faceplate to return it to "Closed" position. (See Figure 15)

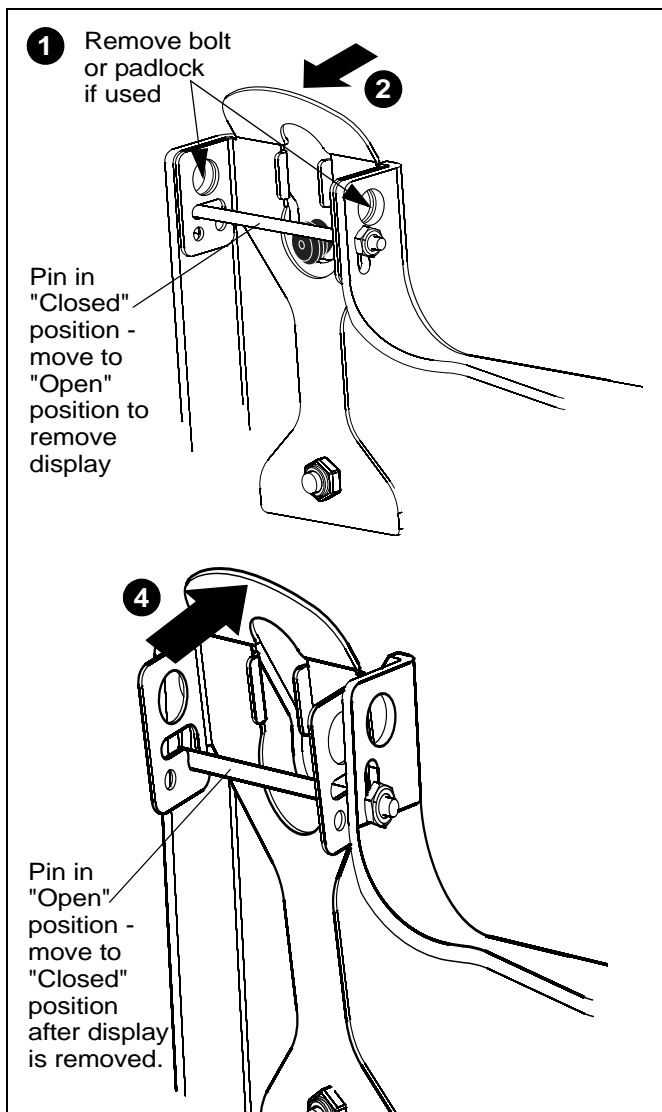

Figure 15



Our Mounts. **Your Vision.**

Chief, a products division of  
Milestone AV Technologies

8800-002572 Rev01

©2015 Milestone AV Technologies

[www.chiefmfg.com](http://www.chiefmfg.com)

10/15

<b>USA/International</b>	<b>A</b> 6436 City West Parkway, Eden Prairie, MN 55344
	<b>P</b> 800.582.6480 / 952.225.6000
	<b>F</b> 877.894.6918 / 952.894.6918
<b>Europe</b>	<b>A</b> Franklinstraat 14, 6003 DK Weert, Netherlands
	<b>P</b> +31 (0) 495 580 852
	<b>F</b> +31 (0) 495 580 845
<b>Asia Pacific</b>	<b>A</b> Office No. 918 on 9/F, Shatin Galleria 18-24 Shan Mei Street Fotan, Shatin, Hong Kong
	<b>P</b> 852 2145 4099
	<b>F</b> 852 2145 4477

