

INSTALLATION INSTRUCTIONS

Lateral Shift Accessory

Model: PAC-125/PAC-126

The PAC-125 Lateral Shift Accessory is for use with Chief Model PSM, PST, PRO, PLP, Large Flat Panel Display wall mounts. It can be installed on either a 16" or 24" on-center stud systems, and includes seven mounting holes at 4" intervals. The PAC-125 is also grooved for drilling at other intervals.

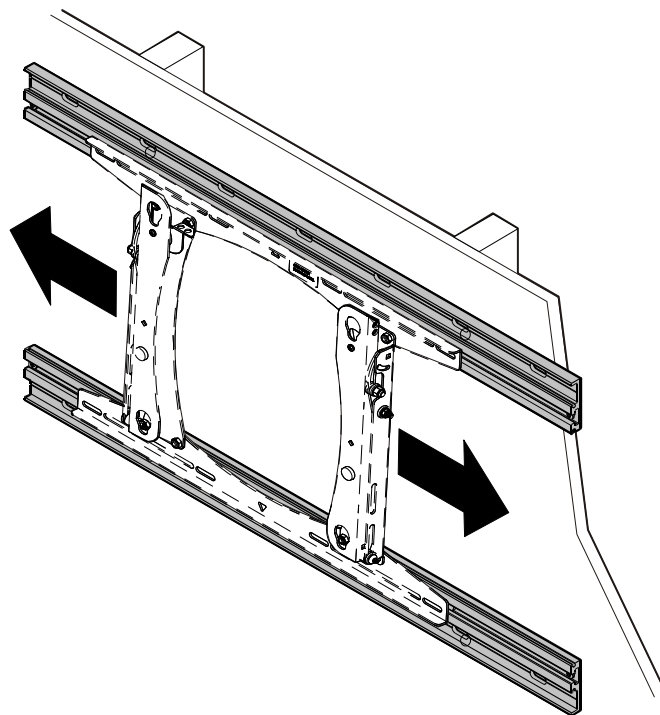

PAC-125 with mount (not included) installed.

BEFORE YOU BEGIN

▲ CAUTION!

The instructions provided in this document outline the installation of the PAC-125 Lateral Shift Accessory to specific Chief mounts. If you have questions regarding the use or installation of this accessory, contact a Chief Customer Service representative at 1-800-582-6480 before proceeding with the installation.

▲ CAUTION!

To prevent damage to the Kit, which could affect or void the Factory warranty, and to the equipment that will be attached to it, thoroughly study all instructions and illustrations before you begin the installation.

! IMPORTANT WARNINGS AND CAUTIONS!

WARNING: A WARNING alerts you to the possibility of serious injury or death if you do not follow the instructions.

CAUTION: A CAUTION alerts you to the possibility of damage or destruction of equipment if you do not follow the corresponding instructions.

! WARNING!

IMPROPER INSTALLATION CAN LEAD TO THE MOUNT FALLING. The structure to which the mount is installed must be capable of supporting 4 times the combined weight of this accessory, the mount and the display. If the structural members can not support this weight, reinforce the structural members before installing the mount.

! WARNING!

IMPROPER INSTALLATION CAN LEAD TO THE MOUNT FALLING. The load placed on the PAC-150 must not exceed 150 lbs (68.03kg) the maximum weight of the PAC-125 accessory.

! CAUTION!

Changes or modifications not approved by Chief Manufacturing could void user's warranty.

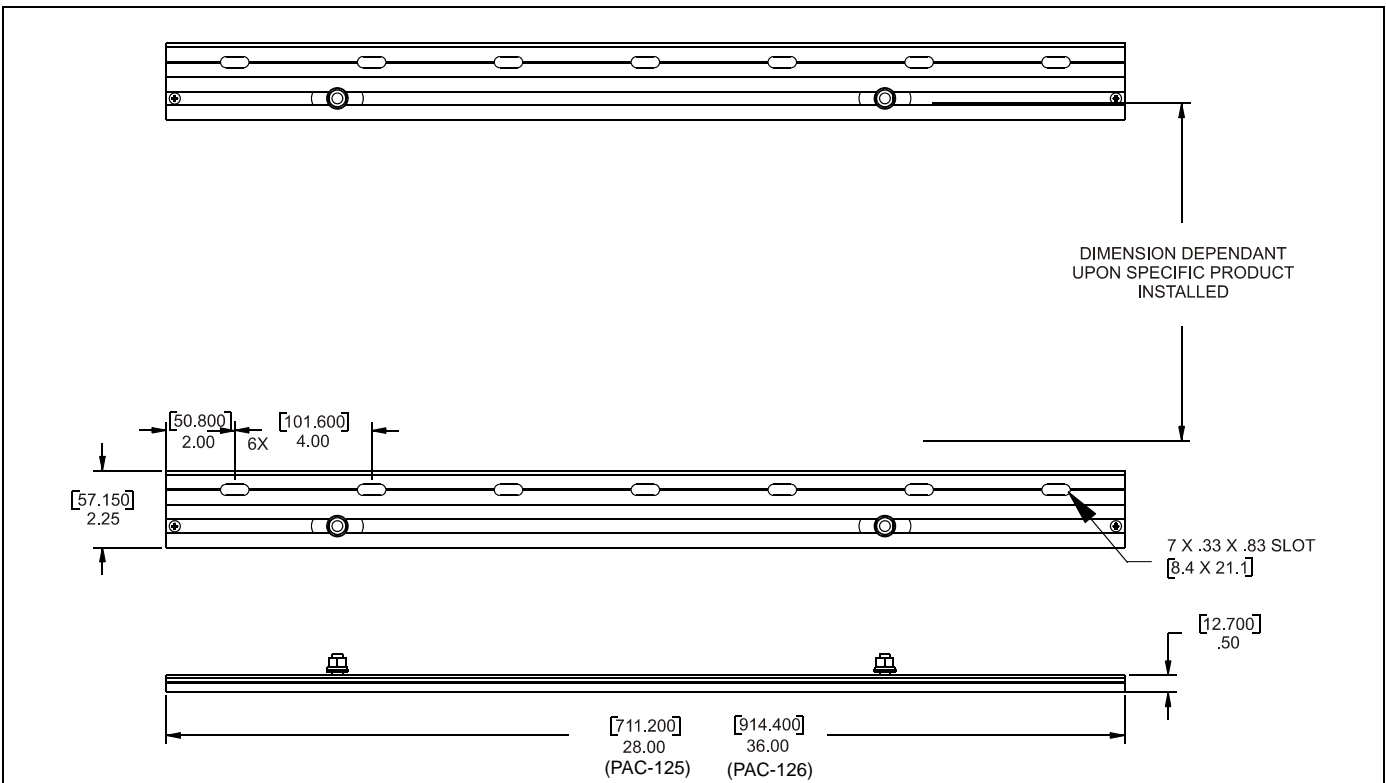

Figure 1: Dimensions

TOOLS REQUIRED FOR INSTALLATION

- Drill and Drill bits
- Phillips Screw Driver

INSPECT MOUNT BEFORE ASSEMBLY

⚠ CAUTION!

Carefully inspect components for shipping damage. If damage is apparent, call your carrier claims agent and do not continue with installation until the carrier has reviewed the damage. (see Figure 2)

Table 1: Parts

ITEM	DESCRIPTION	QTY*
10	BRACKET, Lateral Shift PAC-125 28.00" long/PAC-126 36.00" long	2
20	NUT, T-Slot, 5/16-18	4
30	STUD, Threaded, 5/16-18	4
40	WASHER, Lock, 5/16"	4
50	NUT, Hex, 5/16-18	4
60	SCREW, Panhead, Self Tapping, #8 x 1/4"	4
70	WASHER, Flat, 1/4"	4

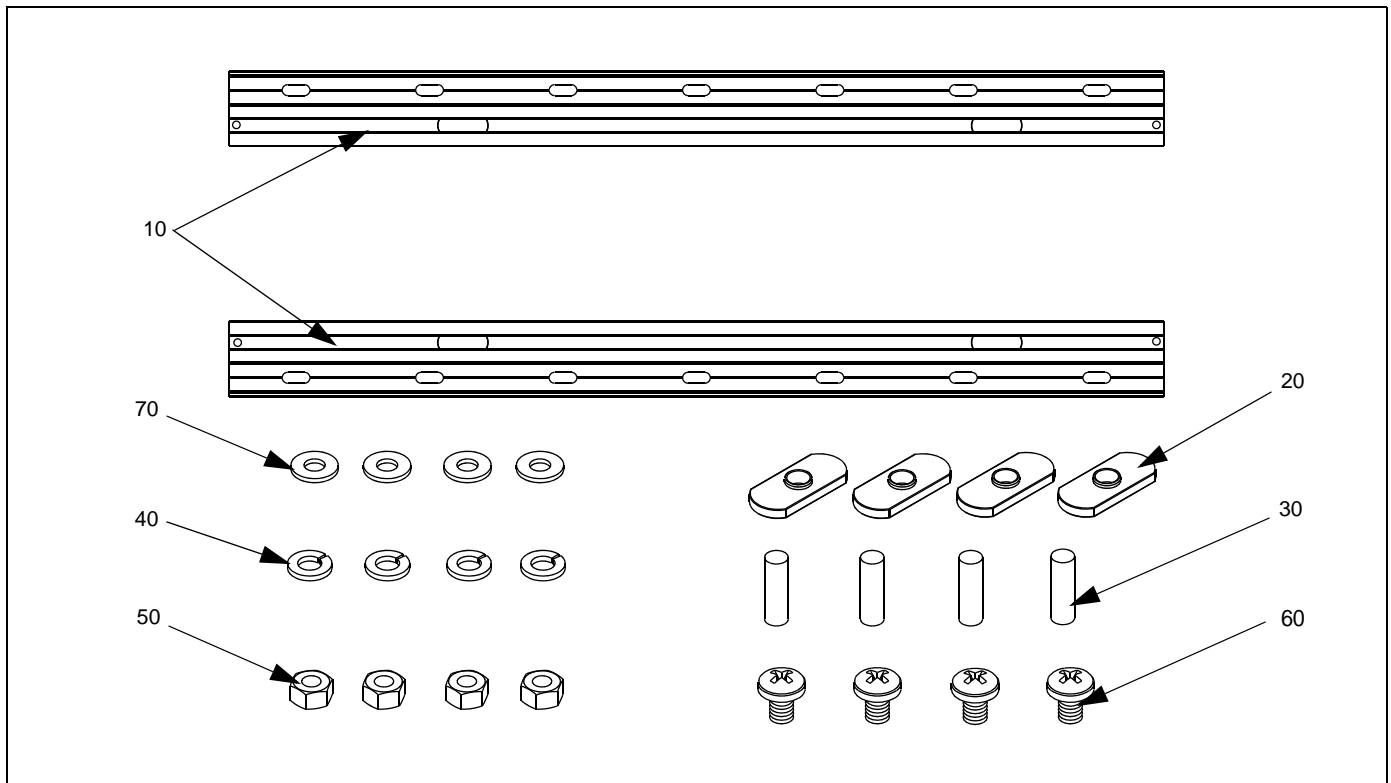

Figure 2: Parts

ASSEMBLY AND INSTALLATION

Lateral Shift Bracket Assembly

1. Assemble four threaded studs (30) to four T-Slot nuts (20).
2. Slide T-Slot nut assembly into bracket (10) channel.
3. Install four self tapping screws (60) into bracket (10) ends. (see Figure 3)

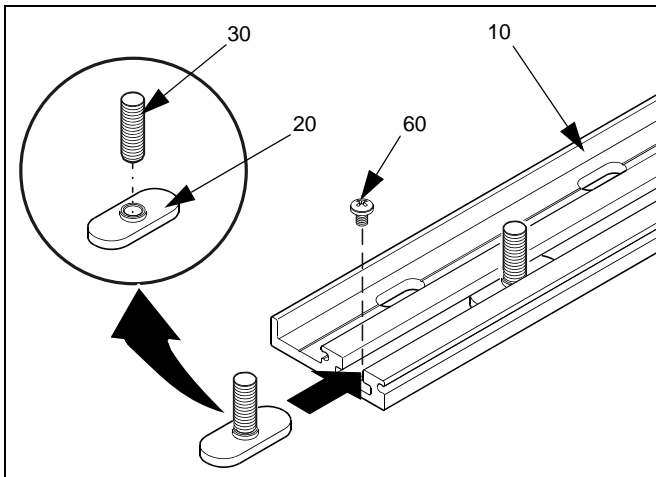

Figure 3: Install T-Slot Nuts on Lateral Shift Bracket

Installation

⚠ WARNING!

IMPROPER INSTALLATION CAN LEAD TO THE MOUNT FALLING. The structure to which the PAC-125 is installed must be capable of supporting 4 times the combined weight of the accessory, the mount and the display.

1. Identify desired mounting location considering:
 - Structural integrity of desired location.
 - Length of PAC-125 mounting brackets
 - Size of display being mounted
2. Determine distance between vertical mounting holes on the mount being installed by referring to the Installation Instructions provided with the mount. (see Figure 4)
3. Add 2 1/8" to the dimension identified during step 1.

⚠ CAUTION!

2 1/8" must be added to the dimension identified during step 1 for proper locating of pilot holes.

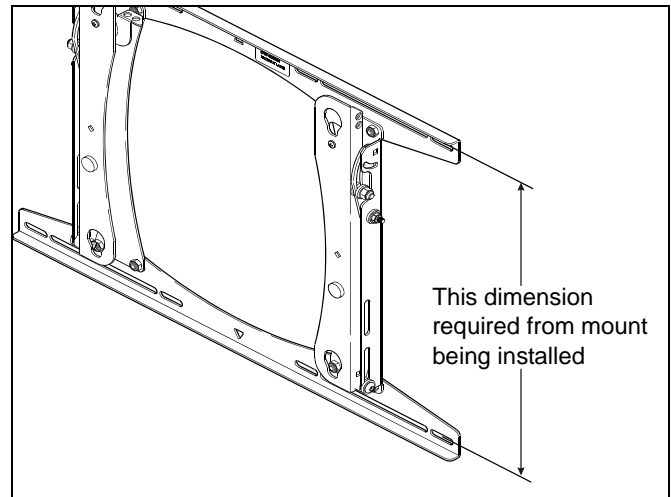

Figure 4: Identify distance between Vertical Mounting Holes on mount

4. Locate and mark four pilot hole locations.
5. Drill four pilot holes using drill size specified in Installation Instructions provided with mount being installed.

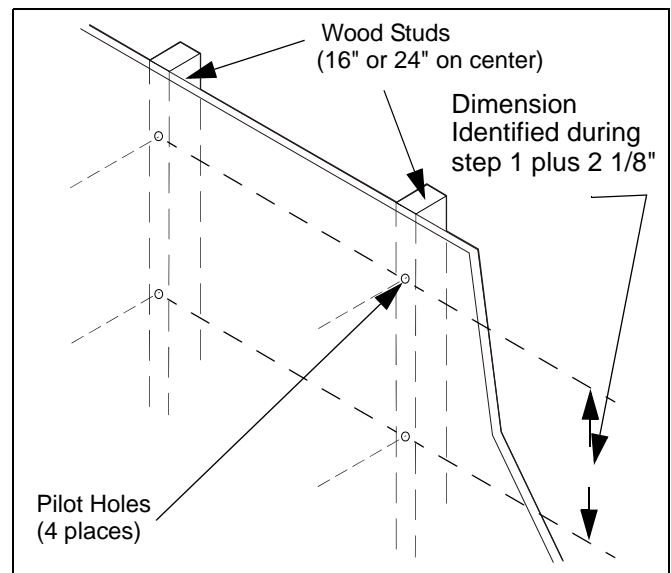

Figure 5: Mark and Drill Pilot Holes

6. Position upper bracket against wall with mounting slots up and align with pilot holes. (see Figure 6)
7. Secure upper bracket to wall using hardware specified in installation instructions provided with mount being installed.
8. Position lower bracket against wall with mounting slots up and align with pilot holes. (see Figure 6)
9. Secure lower bracket to wall using hardware specified in installation instructions provided with mount being installed.

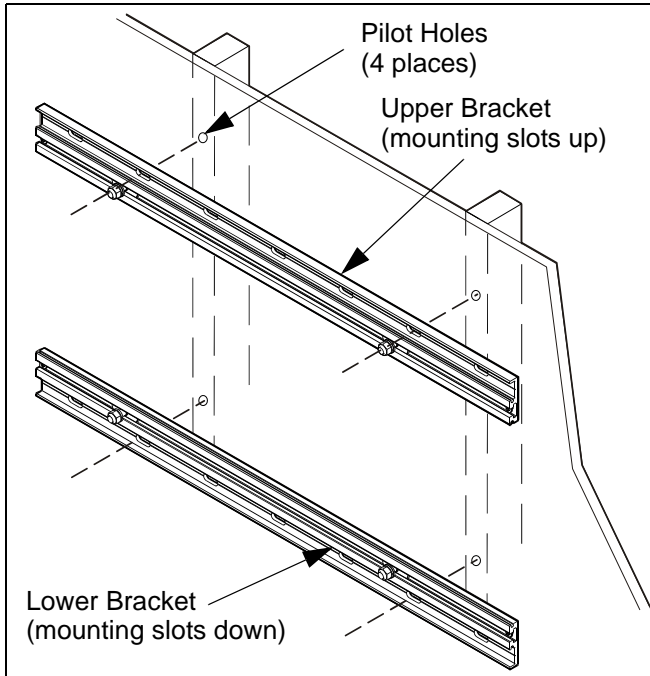

Figure 6: Mount Lateral Shift Brackets on Wall

10. Identify mounting holes in mount being installed using the installation instructions provided with the mount.
11. Position mounting studs in upper and lower lateral shift brackets so that they align with mounting holes in mount being installed.

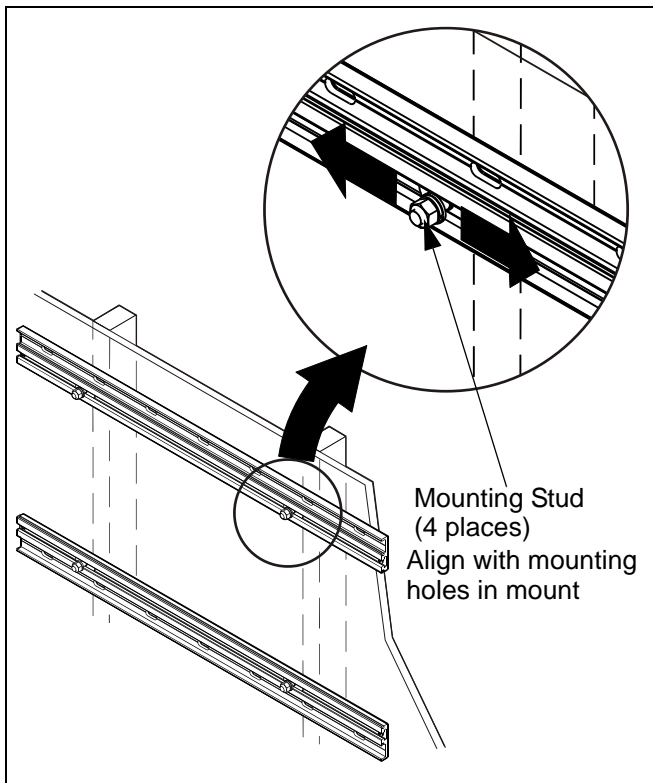

Figure 7: Position Mounting Tabs

12. Place mount onto mounting studs on lateral shift brackets and secure using four Flat washers (70), four lock washers (40), and four hex nuts (50). (see Figure 8)

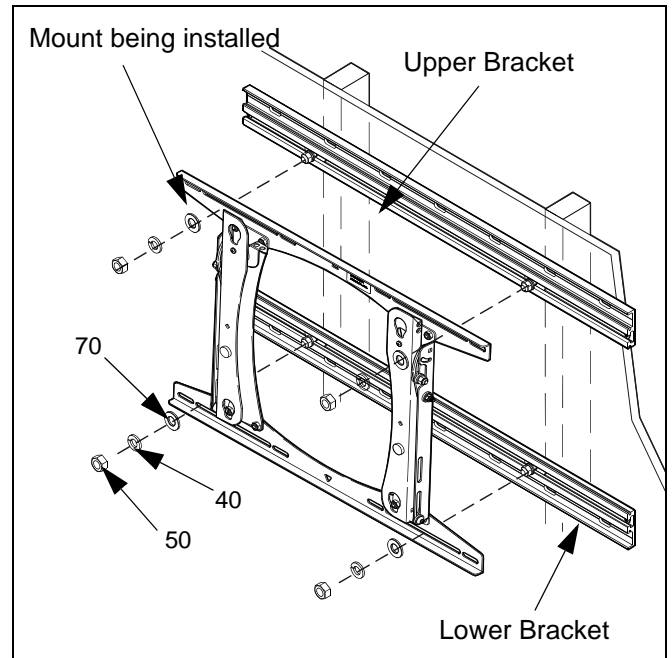

Figure 8: Install Mount to Lateral Shift Brackets

