

INSTALLATION INSTRUCTIONS

Projector Lock (PL-1)

The PL-1 projector lock, constructed with heavy gauge steel, is designed to prevent access to projector mounts. The projector lock protects against disconnecting projectors from their mounts in most high-risk environments, minimizing the probabilities theft.

The design of the PL-1 ensures proper ventilation for your projector while providing excellent security and protection.

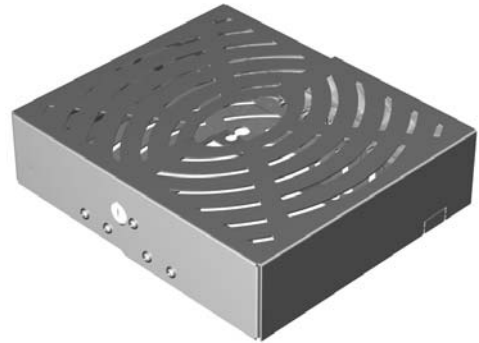

PL-1

BEFORE YOU BEGIN

- **CAUTION: To prevent damage to your display, which could affect or void the Factory warranty, thoroughly study all instructions and illustrations before you begin to install the mount brackets. Pay particular attention to the “Important Warnings and Cautions” on Page 2.**
- If you have any questions about this installation, contact Chief Manufacturing.

Chief® is a registered trademark of Milestone AV Technologies. All rights reserved.



Chief Manufacturing, a division of Milestone AV Technologies
8401 Eagle Creek Parkway, Savage, MN 55378
P: 800.582.6480 / 952.894.6280 F: 877.894.6918 / 952.894.6918

8803-000065 Rev C
©2008 Milestone AV Technologies
05/08

IMPORTANT WARNINGS and CAUTIONS!

- WARNING** A **WARNING** alerts you to the possibility of serious injury or death if you do not follow the instructions.

- CAUTION** A **CAUTION** alerts you to the possibility of damage or destruction of equipment if you do not follow the corresponding instructions.

- **WARNING** **Improper installation can result in serious personal injury! Make sure that the mounting surface can support a redundant weight factor *five times* the total weight of the equipment. If not, reinforce the mounting surface structural members before installing the mount.**

- **WARNING** **Make sure the mount is correctly oriented.**

- **CAUTION** Check the unit for shipping damage before you begin the installation.

DIMENSIONAL DRAWING

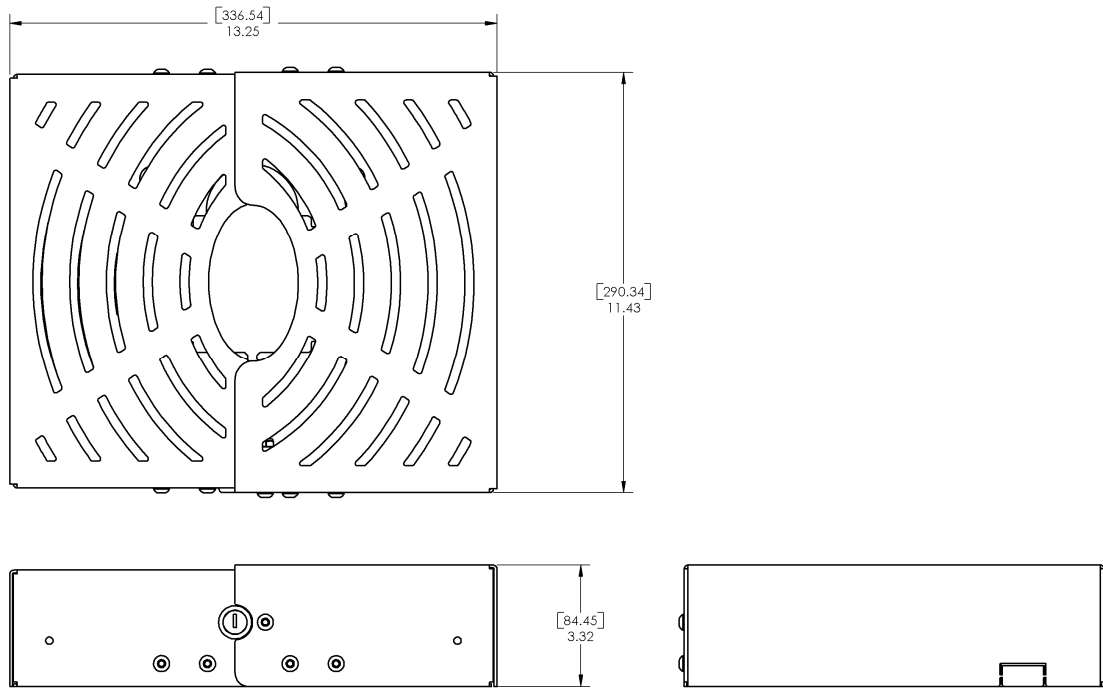

CONTENTS

DIMENSIONAL DRAWING2
 TOOLS REQUIRED FOR INSTALLATION.....3
 PARTS LIST3
 INSPECT INSTALLATION LOCATION.....3
 INSTALLATION.....4

PARTS LIST

Prior to assembly, unpack the carton completely. Verify contents listed in Table 1.

Read installation instructions completely. If you are missing any of the listed parts, contact Customer Service at: 1-800/582-6480.

TOOLS REQUIRED FOR INSTALLATION

- Allen wrench set

NOTE: Other tools may be required depending on your method of installation.

Table 1. Parts List

REF	DESCRIPTION	QTY
10	PL-1 Projector Lock	1
20	Screws	4
30	Spacers	4
PL1A*	Key C346A OR	2
PL1B*	Key C346B OR	2
PL1C*	Key C346C	2

*The PL-1 is shipped with two matching keys: PL1A, or PL1B, or PL1C. To ensure security, the PL-1 is shipped with one of three different keys.

INSPECT INSTALLATION LOCATION

Because of the wide variety of possible mounting situations, Chief Manufacturing only provides general guidelines for the typical pole-mounted installation.

Study the following information carefully, and make adjustments as necessary to fit your specific installation.

WARNING

There is a potential for personal injury or equipment damage if the projector is not adequately mounted. Be aware of the overall weight of the equipment, including weight of projector and all attaching hardware.

INSTALLATION

This manual contains installation procedures that cover pole-mounted applications:

NOTE: Omit Step 1 thru 3 and proceed to Step 4 if the projector is already installed on the 1-1/2" NPT pipe.

1. If projector is mounted, remove projector and SLB.
2. Loosen the thumbnuts and disconnect your projector from the RPA.
3. Install the RPA mount on the 1-1/2" NPT pipe as described in the instructions for your RPA mount.
4. Unlock and open the PL-1.
5. Align set screw of RPA with key lock of cage (see Figure 1).
6. Tilt the lock side of the PL-1 down and route the RPA thru the hole in the PL-1 (see Figure 2).
7. Set PL-1 on RPA (see Figure 3).

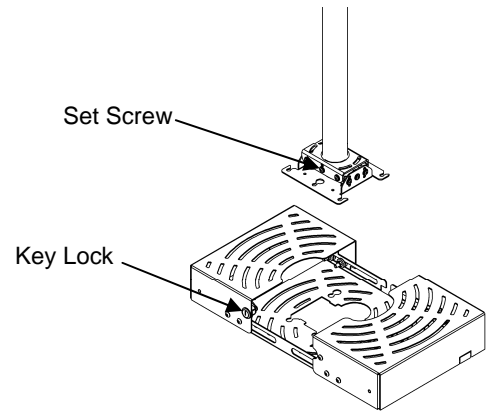

Figure 1. Align Set Screw & Key Lock

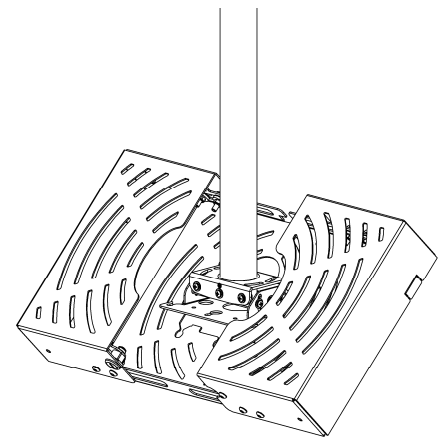

Figure 2. Place PL-1 on RPA

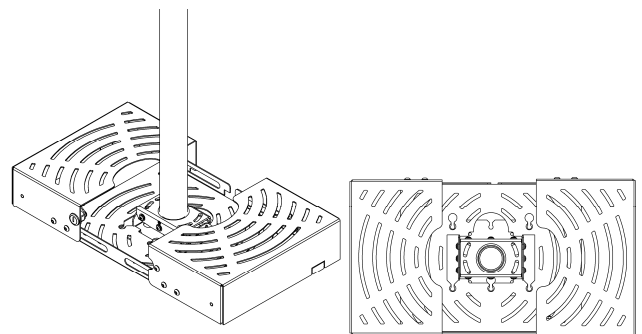
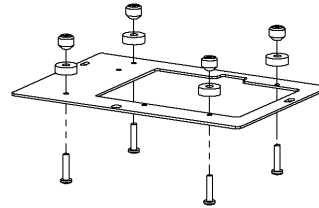
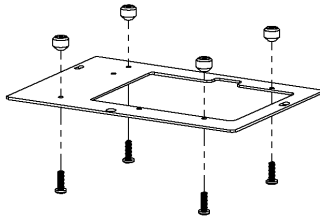
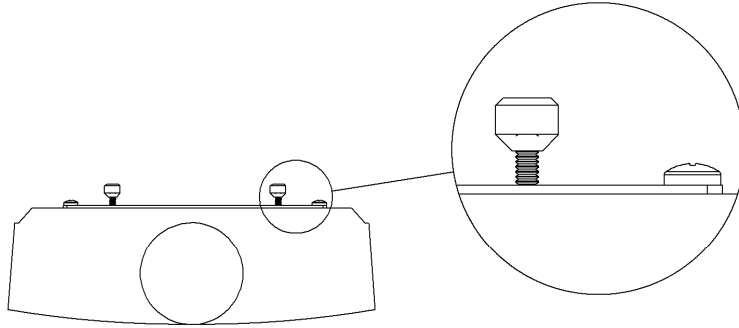

Figure 3. PL-1 on RPA

INSTALLATION (CONT'D)

8. Install the projector (see Figure 4).
9. Tightening the center thumb screw first, make sure all thumb screws are tight.



INSTALLATION (CONT'D)

10. Route the cables (Figure 5).
11. Slide PL-1 halves together (see Figure 6).
12. Insert key.
13. To operate the lock, do the following:
 - a. To lock the PL-1, turn the key (supplied) 90° clockwise.
 - b. To unlock the PL-1, turn the key (supplied) 90° counterclockwise.
14. Remove key.

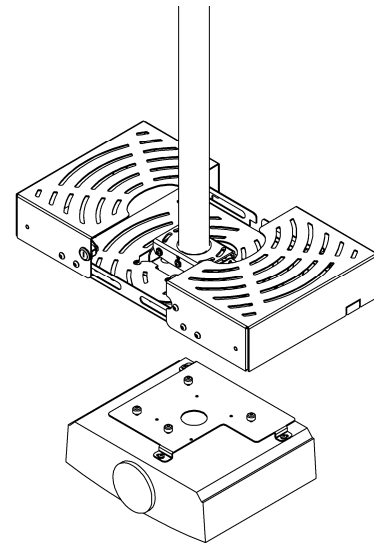

Figure 4. Install Projector

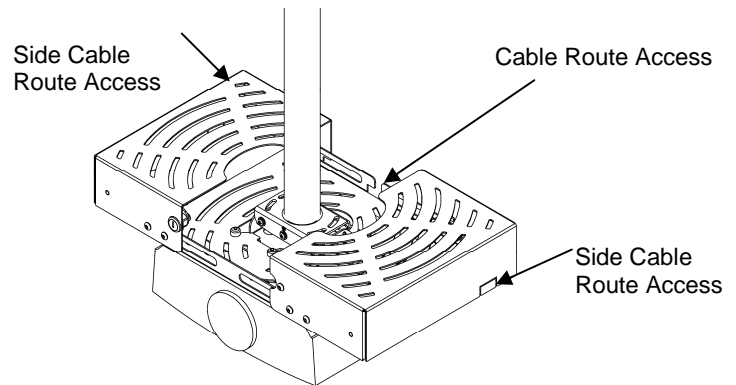

Figure 5. Route Cables

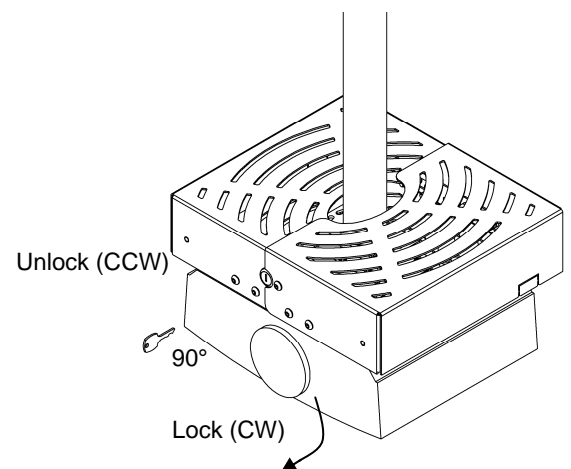

Figure 6. Lock Unit

