

---

# INSTALLATION INSTRUCTIONS

---

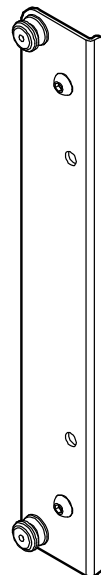
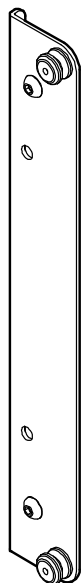

---

## Large Flat Panel Interface Bracket

---

**DISCLAIMER**

Milestone AV Technologies and its affiliated corporations and subsidiaries (collectively "Milestone"), intend to make this manual accurate and complete. However, Milestone makes no claim that the information contained herein covers all details, conditions or variations, nor does it provide for every possible contingency in connection with the installation or use of this product. The information contained in this document is subject to change without notice or obligation of any kind. Milestone makes no representation of warranty, expressed or implied, regarding the information contained herein. Milestone assumes no responsibility for accuracy, completeness or sufficiency of the information contained in this document.

Chief® is a registered trademark of Milestone AV Technologies. All rights reserved.

**! IMPORTANT SAFETY INSTRUCTIONS**

**! WARNING:** A WARNING alerts you to the possibility of serious injury or death if you do not follow the instructions.

**! CAUTION:** A CAUTION alerts you to the possibility of damage or destruction of equipment if you do not follow the corresponding instructions.

**! WARNING:** Failure to read, thoroughly understand, and follow all instructions can result in serious personal injury, damage to equipment, or voiding of factory warranty! It is the installer's responsibility to make sure all components are properly assembled and installed using the instructions provided.

**! WARNING:** Failure to provide adequate structural strength for this component can result in serious personal injury or damage to equipment! It is the installer's responsibility to make sure the structure to which this component is attached can support five times the combined weight of all equipment. Reinforce the structure as required before installing the component. The wall to which the mount is being attached may have a maximum drywall thickness of 5/8" (1.6cm).

**! WARNING:** Exceeding the weight capacity can result in serious personal injury or damage to equipment! It is the installer's responsibility to make sure the maximum weight installed on the interface bracket doesn't exceed 200 lbs (90.7 kg).

**! WARNING:** Use this mounting system only for its intended use as described in these instructions. Do not use attachments not recommended by the manufacturer.

**! WARNING:** Never operate this mounting system if it is damaged. Return the mounting system to a service center for examination and repair.

**! WARNING:** Do not use this product outdoors.

**--SAVE THESE INSTRUCTIONS--**

**DIMENSIONS**

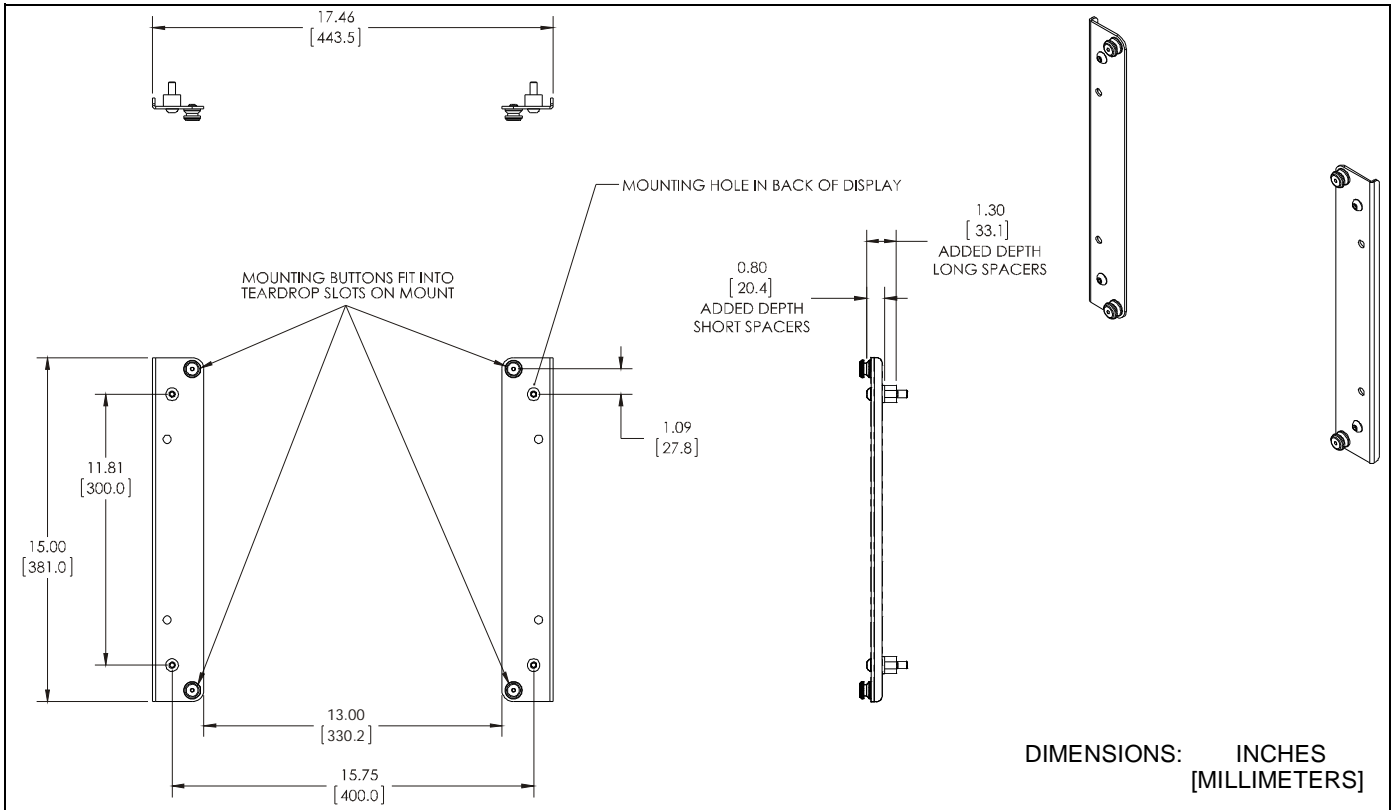

**TOOLS / PARTS FOR INSTALLATION**

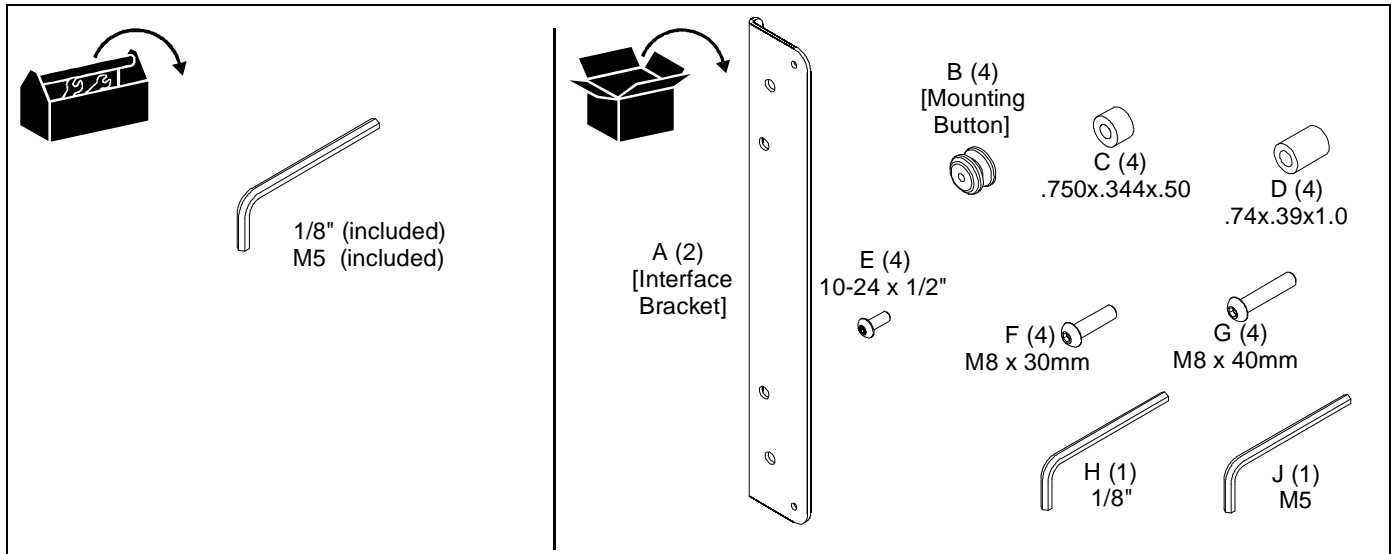

**ASSEMBLY AND INSTALLATION**

1. Attach mounting buttons (B) to interface brackets (A) using four 10-24 x 1/2" button head cap screws (E) and the 1/8" hex key (H). (See Figure 1)

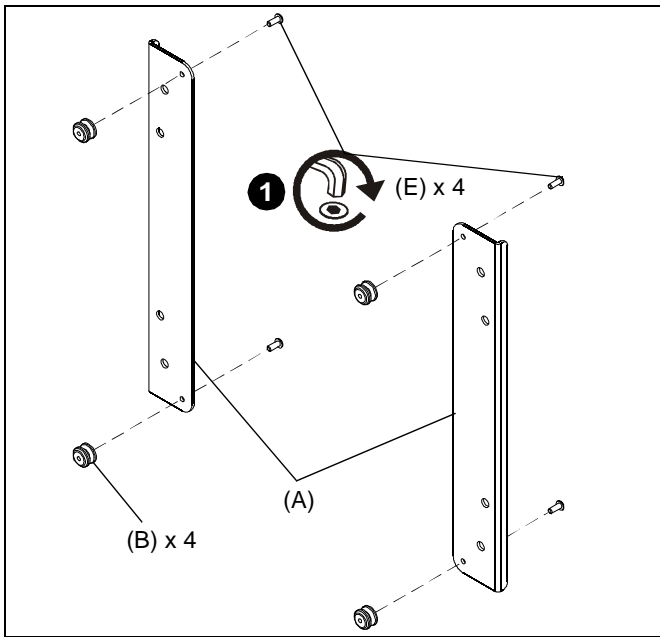

**Figure 1**

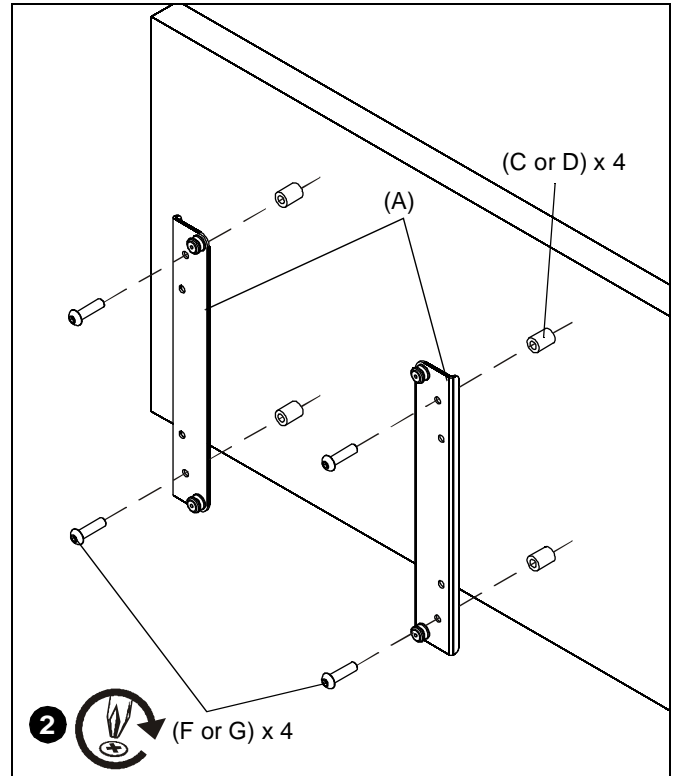

**Figure 2**

**NOTE:** For displays with recessed mounting holes, use M8 x 40mm button head cap screws (G) with spacers (D).

2. Place nylon spacers (C or D) over mounting holes of display and attach brackets to back of display using the M8 x 30mm button head cap screws (F) with spacer (C), **OR** M8 x 40mm button head cap screws with spacer (D). (See Figure 2).

**IMPORTANT ! :** Do not over tighten screws!

3. Complete the installation following the mount installation instructions.



Our Mounts. **Your Vision.**

Chief Manufacturing, a products division  
of Milestone AV Technologies

8800-002146 Rev00  
©2012 Milestone AV Technologies, a  
Duchossois Group Company  
[www.chiefmfg.com](http://www.chiefmfg.com)  
02/12

<b>USA/International</b>	<b>A</b> 8401 Eagle Creek Parkway, Savage, MN 55378 <b>P</b> 800.582.6480 / 952.894.6280 <b>F</b> 877.894.6918 / 952.894.6918
<b>Europe</b>	<b>A</b> Franklinstraat 14, 6003 DK Weert, Netherlands <b>P</b> +31 (0) 495 580 852 <b>F</b> +31 (0) 495 580 845
<b>Asia Pacific</b>	<b>A</b> Office No. 1 on 12/F, Shatin Galleria 18-24 Shan Mei Street Fotan, Shatin, Hong Kong <b>P</b> 852 2145 4099 <b>F</b> 852 2145 4477

