

INSTALLATION INSTRUCTIONS

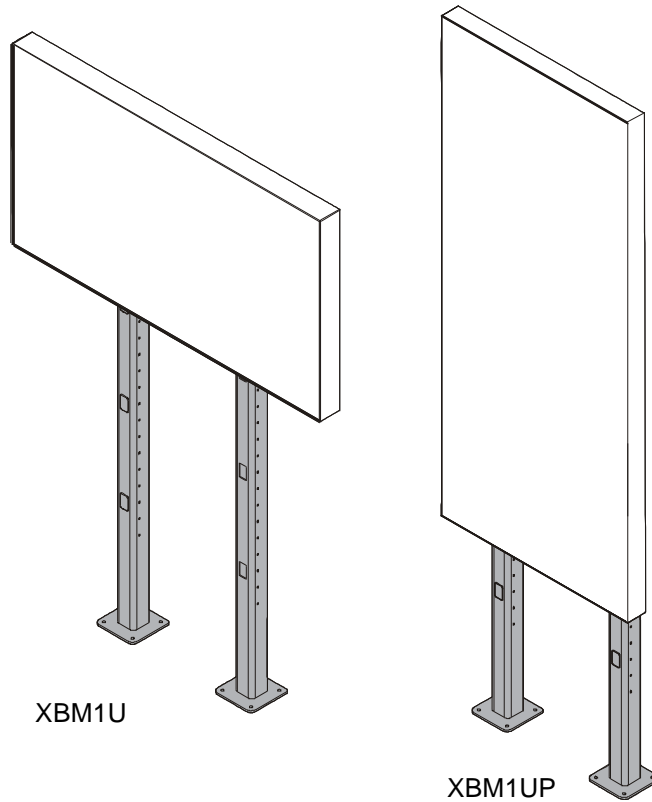

Extra Large Bolt Down Video Wall

DISCLAIMER

Milestone AV Technologies and its affiliated corporations and subsidiaries (collectively "Milestone"), intend to make this manual accurate and complete. However, Milestone makes no claim that the information contained herein covers all details, conditions or variations, nor does it provide for every possible contingency in connection with the installation or use of this product. The information contained in this document is subject to change without notice or obligation of any kind. Milestone makes no representation of warranty, expressed or implied, regarding the information contained herein. Milestone assumes no responsibility for accuracy, completeness or sufficiency of the information contained in this document.

Chief® is a registered trademark of Milestone AV Technologies. All rights reserved.



IMPORTANT SAFETY INSTRUCTIONS



WARNING: A WARNING alerts you to the possibility of serious injury or death if you do not follow the instructions.



CAUTION: A CAUTION alerts you to the possibility of damage or destruction of equipment if you do not follow the corresponding instructions.



WARNING: Failure to read, thoroughly understand, and follow all instructions can result in serious personal injury, damage to equipment, or voiding of factory warranty! It is the installer's responsibility to make sure all components are properly assembled and installed using the instructions provided.



WARNING: Failure to provide adequate structural strength for this component can result in serious personal injury or damage to equipment! It is the installer's responsibility to make sure the structure to which this component is attached can support five times the combined weight of all equipment. Reinforce the structure as required before installing the component.



WARNING: Do NOT stack multiple accessories on the same display wall!



WARNING: Do NOT install XBM1U/XBM1UP mounts to any surface other than concrete! Concrete flooring must be at least 4" in thickness and NOT be covered with any other type of flooring material. Concrete anchors must be installed directly into concrete surface.



WARNING: Exceeding the weight capacity can result in serious personal injury or damage to equipment! It is the installer's responsibility to make sure the combined weight of each display and attached accessories mounted to the XBM1U/XBM1UP mount does not exceed 250 lbs (113.4 kg).

NOTE: The UL Listed XBM1U/XMB1UP video walls may be used with the Listed video wall extension accessory FCABX36 with the FCABX36 being used in place of the existing height extension.



WARNING: Use this mounting system only for its intended use as described in these instructions. Do not use attachments not recommended by the manufacturer.



WARNING: Never operate this mounting system if it is damaged. Return the mounting system to a service center for examination and repair.

NOTE: Refer to UL Listed accessories manuals for installation instructions.

NOTE: The XBM1U/XBM1UP video walls have no user serviceable parts.



WARNING: Do not use this product outdoors.

--SAVE THESE INSTRUCTIONS--

DIMENSIONS

XBM1U

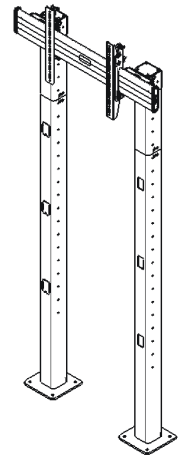
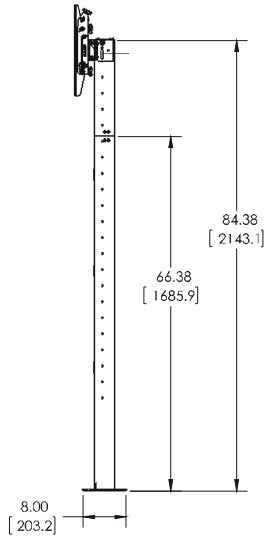
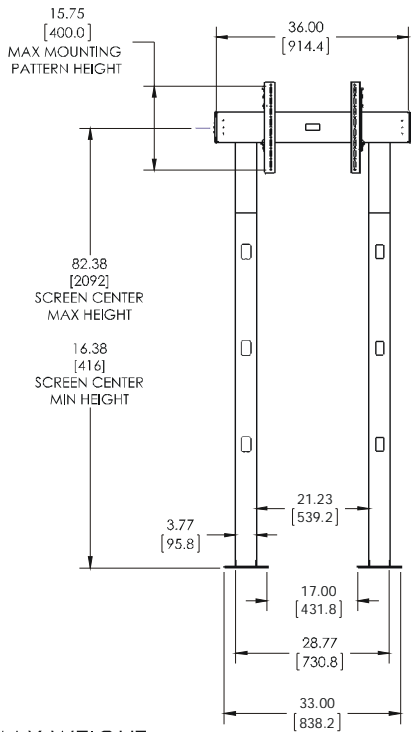

MAX WEIGHT:
250 LBS

XBM1UP

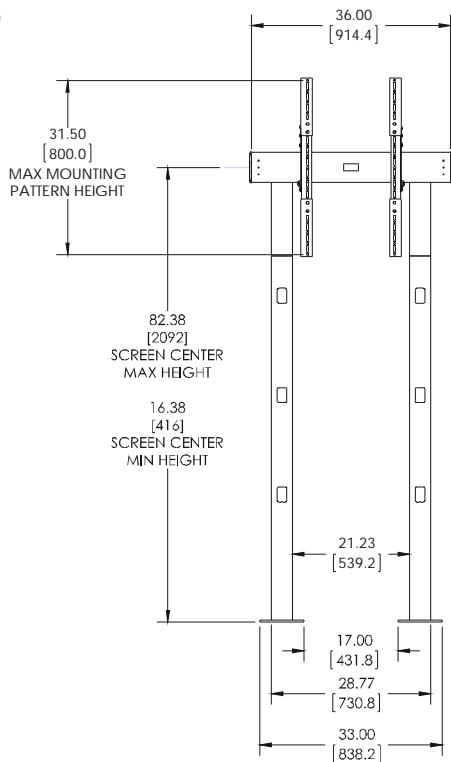

MAX WEIGHT:
250 LBS

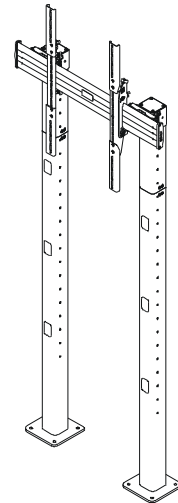
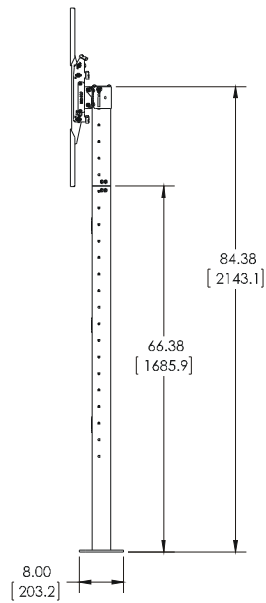

Bolt Down Dimensions

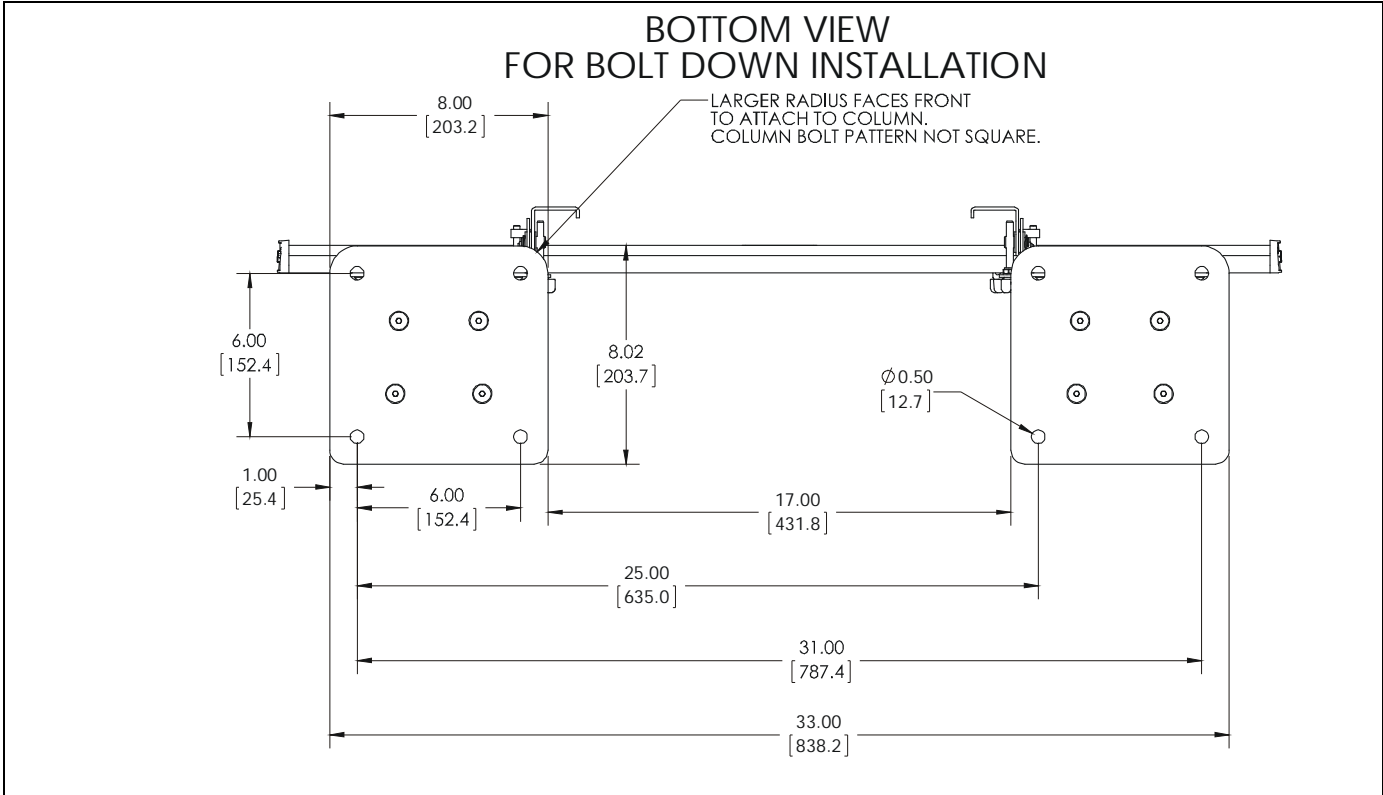

LEGEND

	<p>Tighten Fastener</p> <p>Apretar elemento de fijación</p> <p>Befestigungsteil festziehen</p> <p>Apertar fixador</p> <p>Serrare il fissaggio</p> <p>Bevestiging vastdraaien</p> <p>Serrez les fixations</p>		<p>Pencil Mark</p> <p>Marcar con lápiz</p> <p>Stiftmarkierung</p> <p>Marcar com lápis</p> <p>Segno a matita</p> <p>Potloodmerkteken</p> <p>Marquage au crayon</p>
	<p>Loosen Fastener</p> <p>Aflojar elemento de fijación</p> <p>Befestigungsteil lösen</p> <p>Desapertar fixador</p> <p>Allentare il fissaggio</p> <p>Bevestiging losdraaien</p> <p>Desserrez les fixations</p>		<p>Drill Hole</p> <p>Perforar</p> <p>Bohrloch</p> <p>Fazer furo</p> <p>Praticare un foro</p> <p>Gat boren</p> <p>Percez un trou</p>
	<p>Phillips Screwdriver</p> <p>Destornillador Phillips</p> <p>Kreuzschlitzschraubendreher</p> <p>Chave de fendas Phillips</p> <p>Cacciavite a stella</p> <p>Kruiskopschroevendraaier</p> <p>Tournevis à pointe cruciforme</p>		<p>Adjust</p> <p>Ajustar</p> <p>Einstellen</p> <p>Ajustar</p> <p>Regolare</p> <p>Afstellen</p> <p>Ajuster</p>
	<p>Open-Ended Wrench</p> <p>Llave de boca</p> <p>Gabelschlüssel</p> <p>Chave de bocas</p> <p>Chiave a punte aperte</p> <p>Steeksleutel</p> <p>Clé à fourche</p>		<p>Remove</p> <p>Quitar</p> <p>Entfernen</p> <p>Remover</p> <p>Rimuovere</p> <p>Verwijderen</p> <p>Retirez</p>
	<p>By Hand</p> <p>A mano</p> <p>Von Hand</p> <p>Com a mão</p> <p>A mano</p> <p>Met de hand</p> <p>À la main</p>		<p>Optional</p> <p>Opcional</p> <p>Optional</p> <p>Opcional</p> <p>Opzionale</p> <p>Optie</p> <p>En option</p>
	<p>Hex-Head Wrench</p> <p>Llave de cabeza hexagonal</p> <p>Sechskantschlüssel</p> <p>Chave de cabeça sextavada</p> <p>Chiave esagonale</p> <p>Zeskantsleutel</p> <p>Clé à tête hexagonale</p>		<p>Security Wrench</p> <p>Llave de seguridad</p> <p>Sicherheitsschlüssel</p> <p>Chave de segurança</p> <p>Chiave di sicurezza</p> <p>Veiligheidsleutel</p> <p>Clé de sécurité</p>

TOOLS REQUIRED FOR INSTALLATION

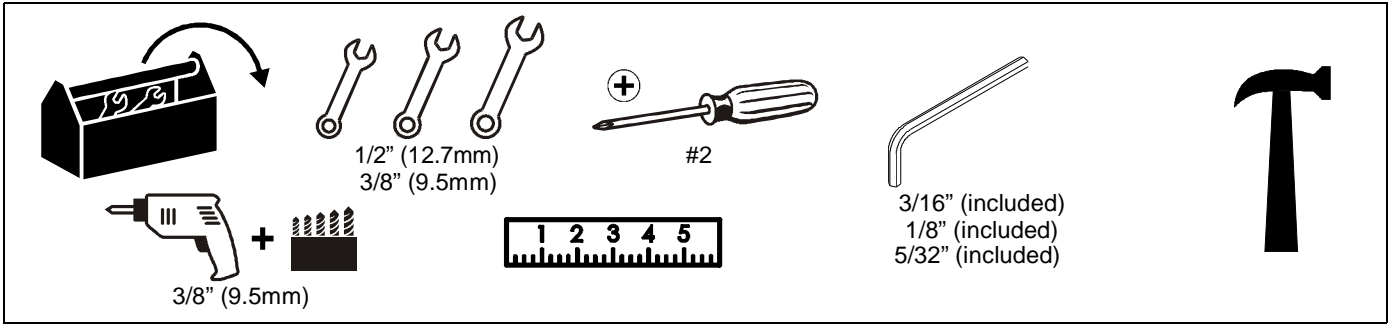

PARTS

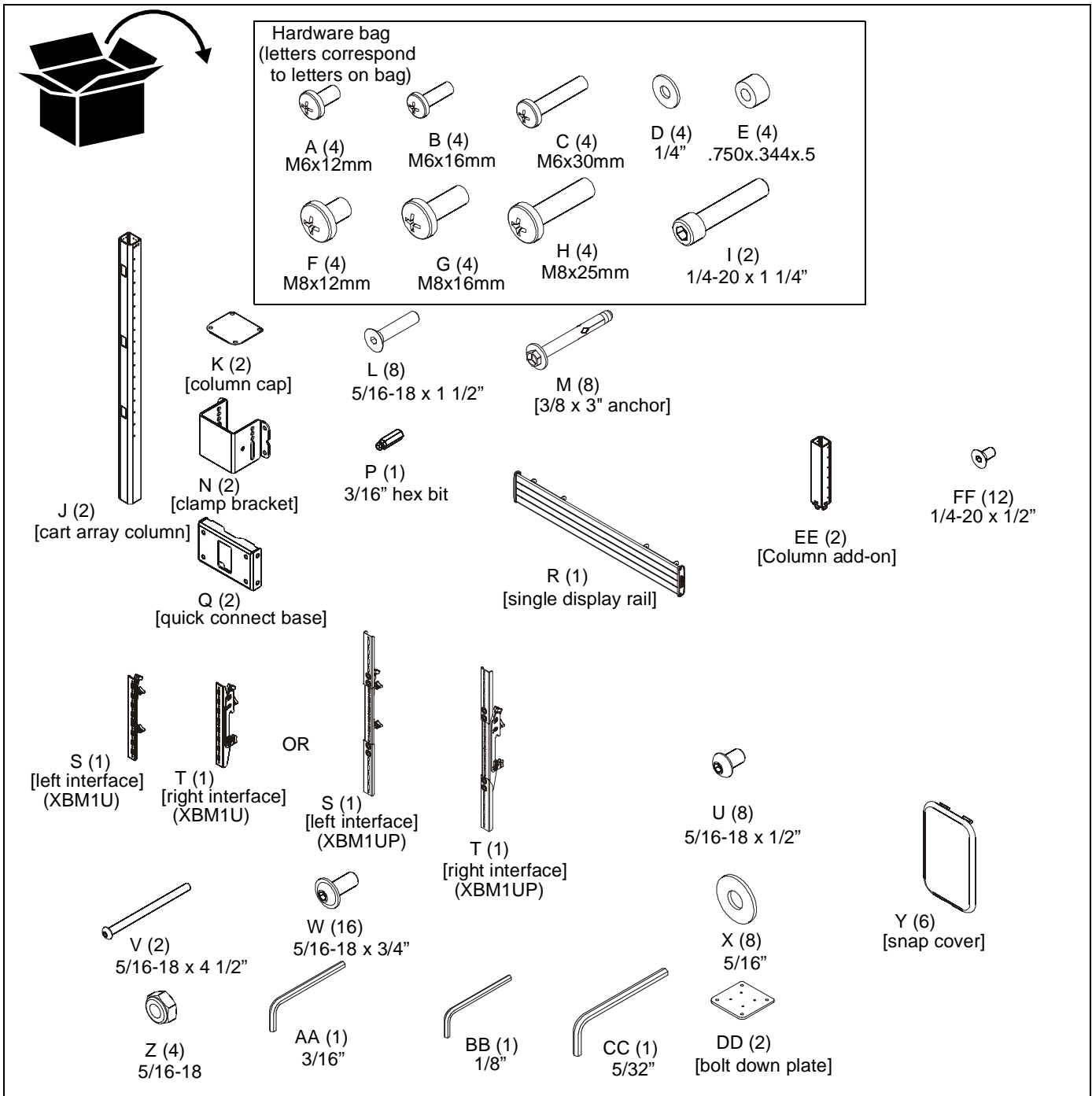

Assembly And Installation

Bolt Down Columns to Floor

1. Lay array columns (M) down on a flat surface.
2. Use four 5/16-18 x 1 1/2" flat head cap screws (L) to connect each bolt down plate (DD) to each column (J). (See Figure 1)

IMPORTANT ! : Inside bolt pattern is NOT square!
 Corners of front of plate have larger radii than corners on back of plate. Plate must be properly aligned in order to attach to column.

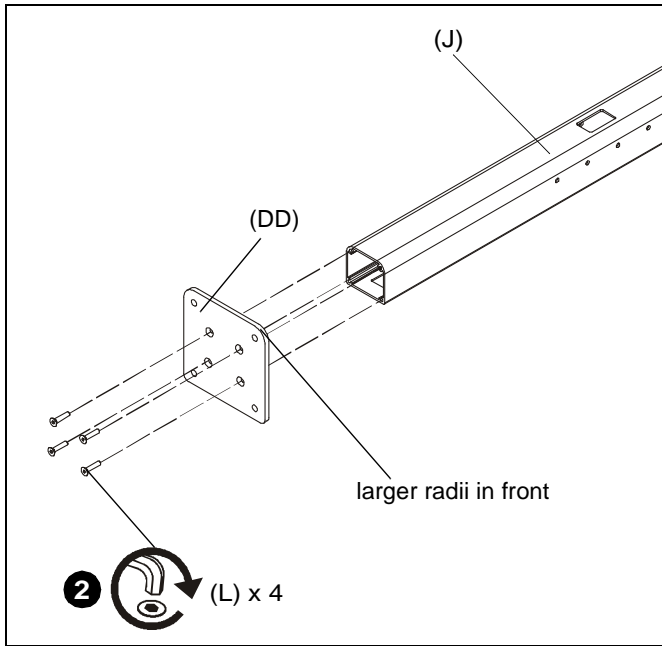

Figure 1

3. Using bolt down plates (DD) as templates, mark four holes at outside hole locations for each column. (See Figure 2)



WARNING: Do NOT install XBM1U mounts to any surface other than concrete! Concrete flooring must be at least 4" in thickness and NOT be covered with any other type of flooring material. Concrete anchors must be installed directly into concrete surface.

IMPORTANT ! : See Bolt Down Dimensions on page 3 to measure distances between each bolt down plate.

IMPORTANT ! : Make sure columns will be installed far enough away from any walls so that displays may be installed.

4. Using a 3/8" drill bit, drill a hole 3 1/2" in depth at each marked location. (See Figure 2) and (See Figure 3)
5. Blow each hole clean of any concrete debris with a large air hose or compressed air in a can. (See Figure 3)

IMPORTANT ! : Do NOT modify the anchors or advance the bolt in the anchors prior to installation!

6. Place each bolt down plate (DD) on top of drilled holes making sure holes on plate are aligned with drilled holes. (See Figure 3)

7. Use a hammer to drive anchors (M) through plate holes into the drilled holes until the bolt head is firmly seated against the plate. (See Figure 2) and (See Figure 3)
8. Tighten each anchor by turning the head three to four turns past finger tight. (See Figure 3)

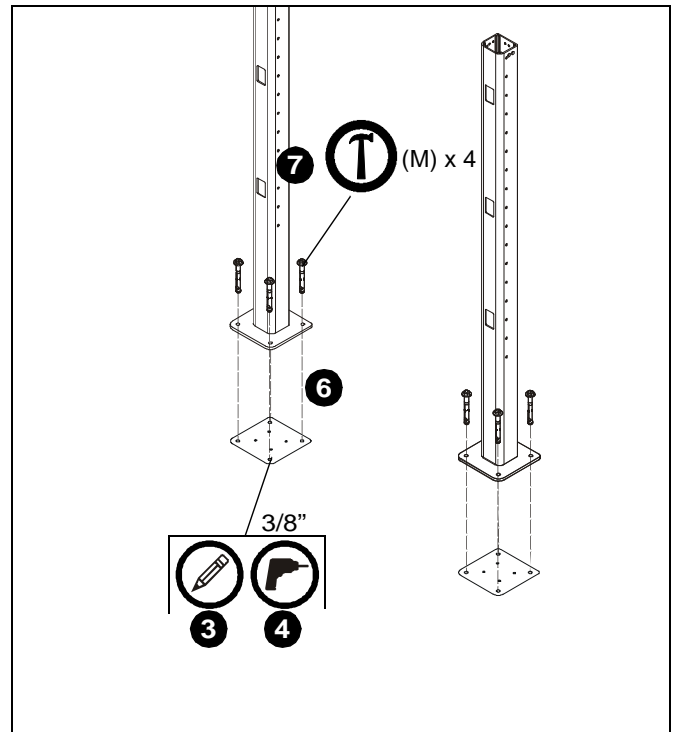

Figure 2

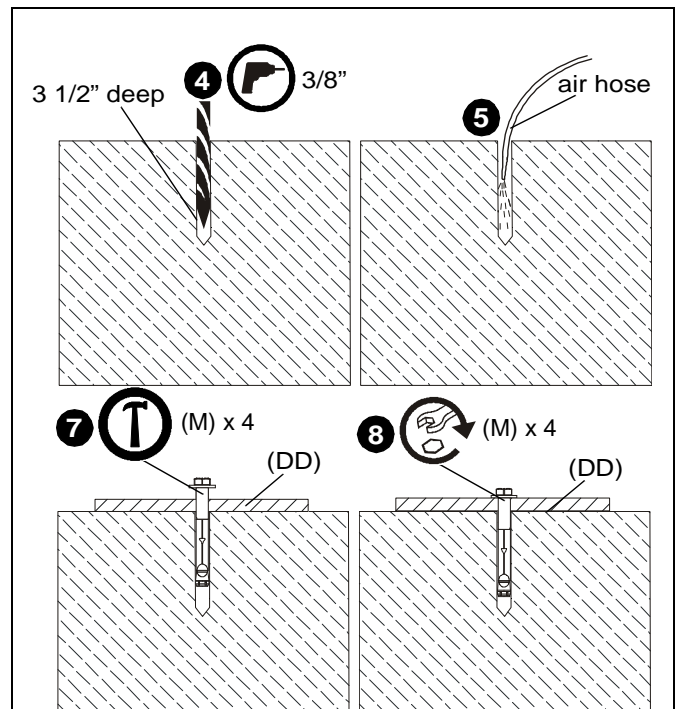

Figure 3

9. Repeat Steps 4-8 for additional column.

Column Add-On Installation (Optional)

NOTE: Column add-ons (EE) are only required for extra large displays or if a higher mounting height is desired than can be achieved with the standard columns (J). If add-ons are not going to be installed, proceed to Rail Installation Section.

1. Insert one column add-on (EE) to each column (J) making sure holes are lined up on each side. (See Figure 4)
2. Use 5/32" hex key (CC) and six 1/4-20 x 1/2" flat head cap screws (FF) to secure each column add-on (V) to each column (J). (See Figure 4)

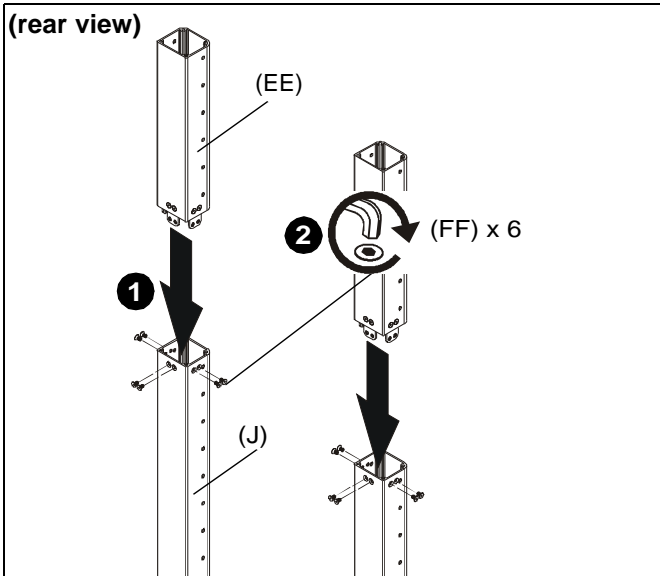

Figure 4

Rail Installation

1. Using display dimensions, determine where the center of the display will be on the cart.

IMPORTANT ! : If installing column add-on accessories (not included), install them prior to installing rail (R) to columns (J).

2. Place clamp brackets (N) on columns in the position of where the center of the display will be on the cart with the diamond on the brackets being placed at the exact center location. (See Figure 5)

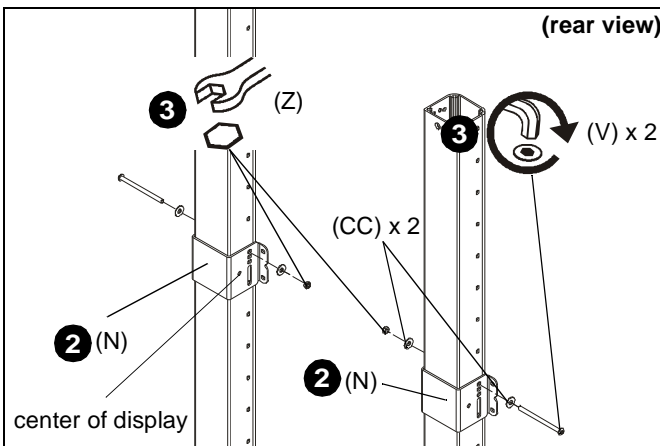

Figure 5

3. Use 5/16-18 x 4 1/2" button head cap screw (V), two 5/16" washers (X) and 5/16-18" lock nut (Z) to secure each clamp bracket (N) to column. (See Figure 5)
4. Use four 5/16-18 x 3/4" button head flange screws (W) to secure each attached clamp bracket (N) to each quick connect base (Q). (See Figure 6)

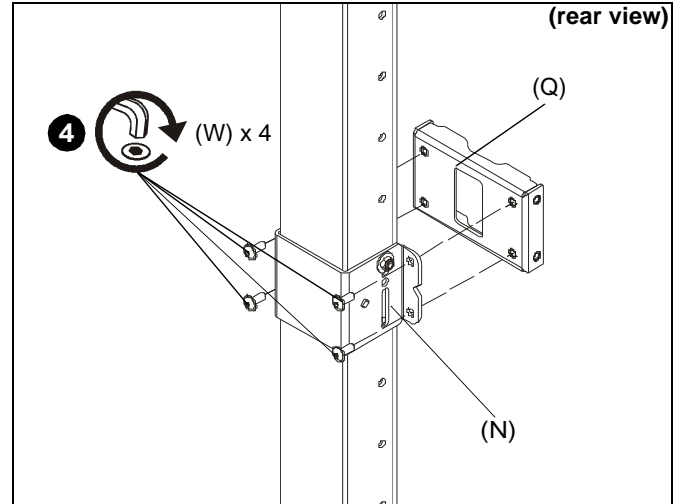

Figure 6

NOTE: If rails must be installed over cable management holes on column, cables must be routed prior to installing rails onto quick connect bases. See Cable Management section for details.

5. Install two 5/16-18 x 3/4" button head flange screws (W) into the top holes on each quick connect base (Q). (See Figure 7)
6. Hang single display rail (R) onto screws installed in previous step to quick connect bases (Q). (See Figure 7)

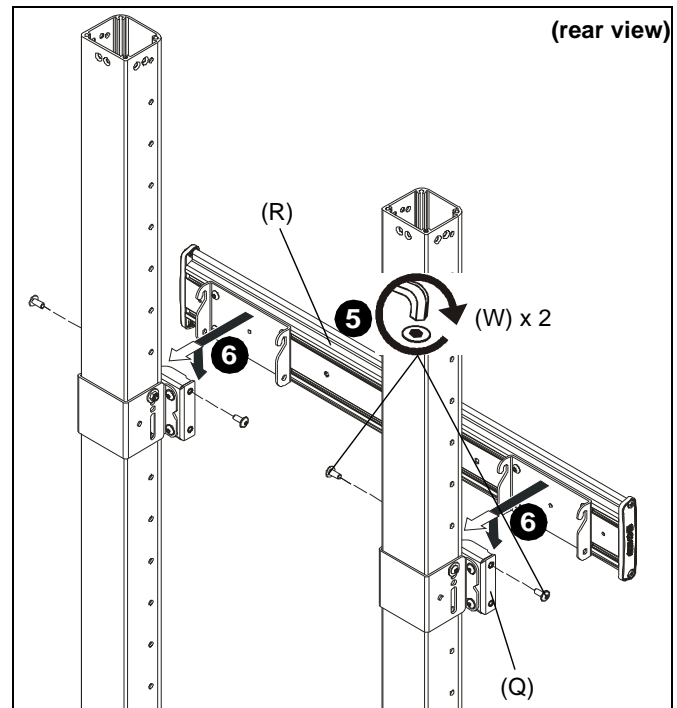

Figure 7

7. Install two 5/16-18 x 3/4" button head flange screws (W) into the lower holes on each quick connect base (Q) to secure rails to quick connect bases. (See Figure 8)
8. Tighten all 5/16-18 x 3/4" button head flange screws (W).

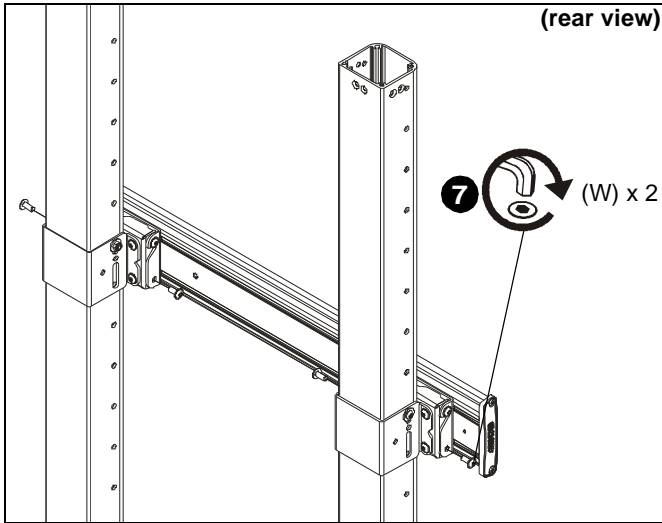

Figure 8

Display Installation

1. Place display face down on a soft, non-abrasive surface.

NOTE: For best access, route display cables through columns prior to display installation. See Cable Management section for details.



CAUTION: Using screws of improper diameter may damage your display! Proper screws will easily thread into display mounting holes.

2. Select screw *diameter* by examining hardware (A-C and F-H) (6mm or 8mm) and comparing with mounting holes on display. (See Figure 9) or (See Figure 10)
3. Select spacers:
 - If mounting holes are not recessed and interface brackets (S and T) can lay flat against display, then no spacers are required.
 - If mounting holes are recessed, or if protrusions prevent brackets (S and T) from laying flat, then spacers (E) must be used.



CAUTION: Using screws of improper length may damage your display! Proper screws will have adequate thread engagement without contacting bottom of display mounting holes.

4. Select screw *length*: (See Figure 9) or (See Figure 10)
 - Using your hand, insert **SHORTEST** length screw of selected diameter (A or F) through 1/4" washer (D), bracket (S or T), selected spacer (E, if required), into display mounting hole. Do **NOT** thread screw into hole at this time.
 - Proper screw length requires base of screw head to protrude above flat washer a *distance equal to or greater than the screw diameter*. If screw length is inadequate, select longer screw. Select *shortest* screw which will protrude the required distance.
5. Use selected screws (A-C or F-H), washers (D) and spacers (E), if necessary, to connect interface brackets (S and T) to back of display. Make sure diamond on interface brackets is even with center of display. (See Figure 9) or (See Figure 10)

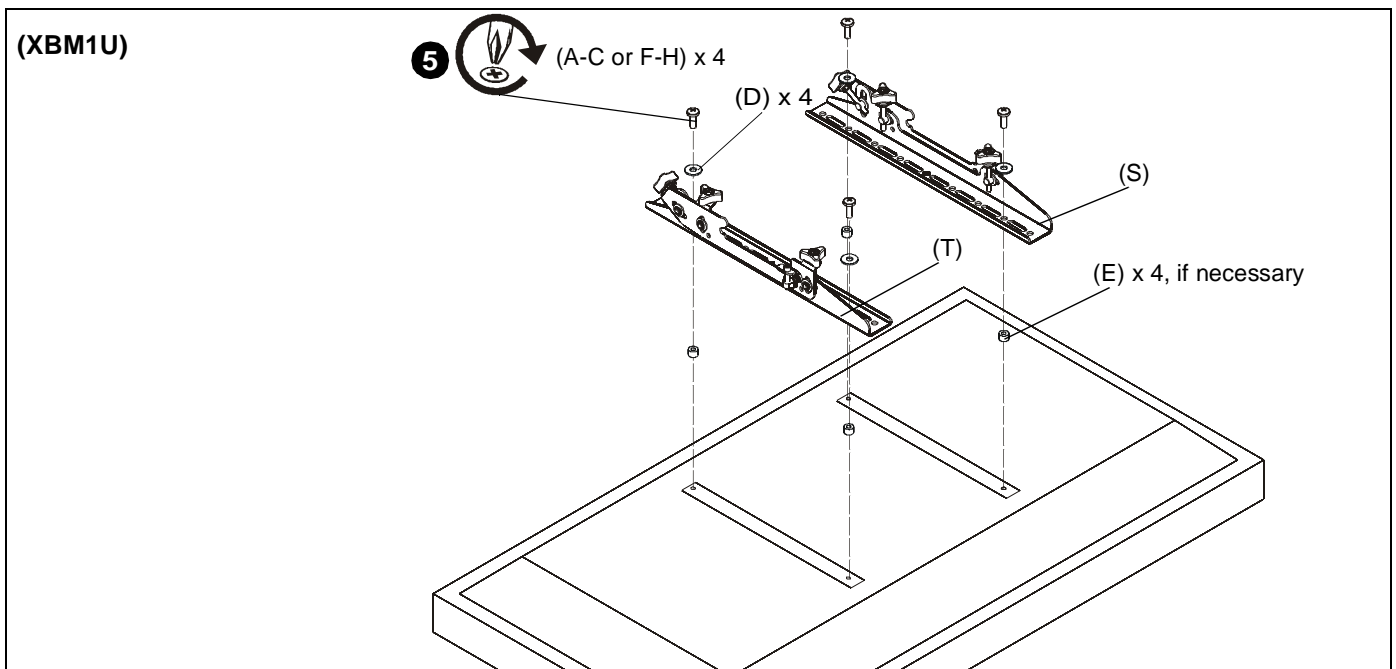

Figure 9

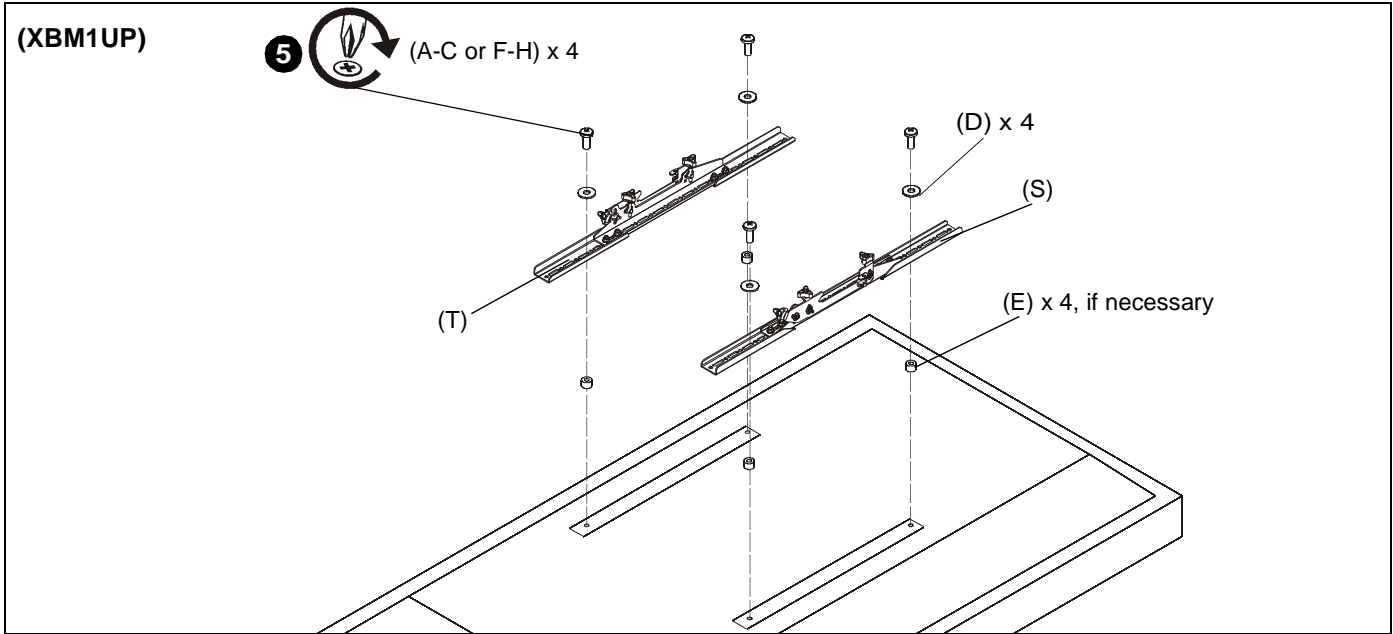

Figure 10



WARNING: Exceeding the weight capacity can result in serious personal injury or damage to equipment! It is the installer's responsibility to make sure the combined weight of each display and attached accessories mounted to the XBM1U/XBM1UP mount does not exceed 250 lbs (113.4 kg).

6. Hang interface brackets (S and T) to single display rail (R). (See Figure 11)
7. Use 1/4-20 x 1 1/4" socket head cap screws (I) to secure interface brackets (S and T) to rails for each display. Screws must engage through both holes to be fully secured. (See Figure 11)

NOTE: Display positions may need to be adjusted after height and/or plumb adjustments in order to maintain desired alignment.

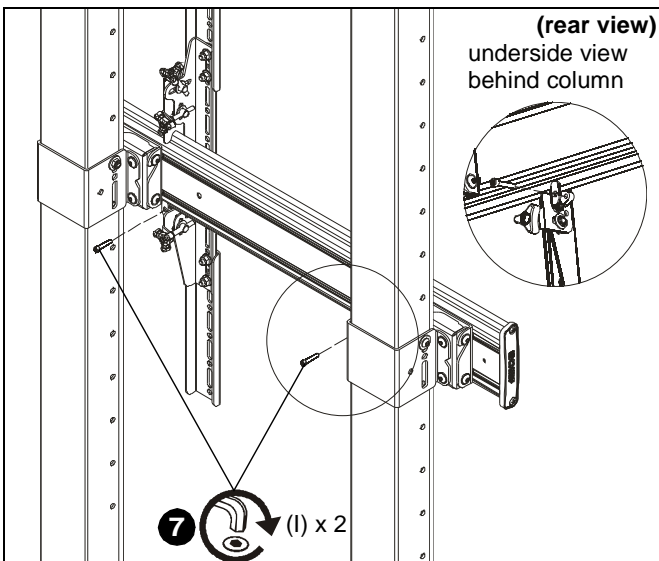

Figure 11

Column Cap Installation

NOTE: If the top holes on columns will be used for cable management, do NOT install column caps to columns as illustrated below. See Cable Management section for details.

1. Use four 5/16-18 x 1/2" button head cap screws (U) to install each column cap (K) to each column. (See Figure 12)

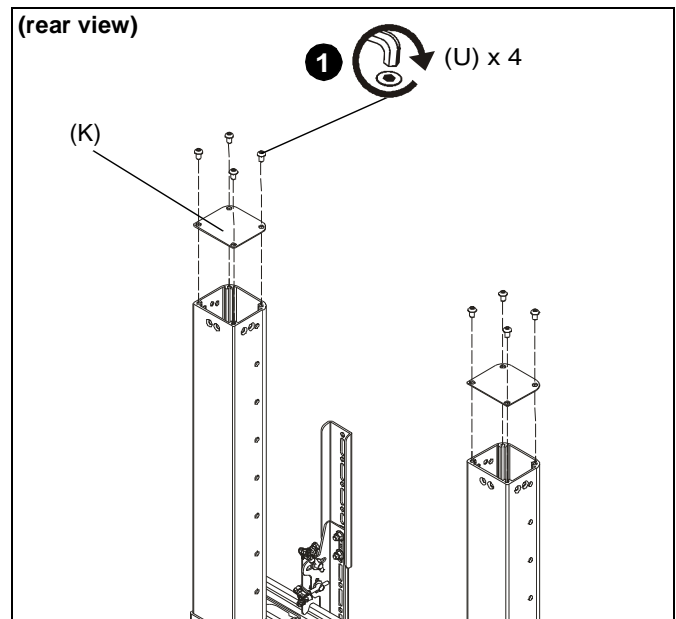

Figure 12

Adjustments

Height Adjustment

1. Use upper knob on back of interface brackets (S and T) to adjust the height of each display. (See Figure 13)

NOTE: Adjust both brackets in order to maintain a level mount.

Plumb Adjustment

2. Use middle and lower knobs on back of interface brackets (S and T) to make plumb adjustments to each display. (See Figure 13)

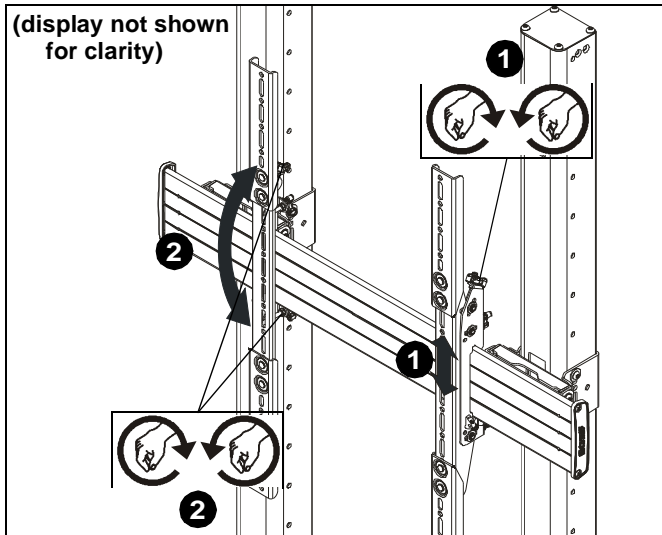

Figure 13

Cable Management

1. Route cables from displays through nearest holes on front of columns and out through back cable management hole. (See Figure 14)

NOTE: For best access, route display cables through columns prior to display installation.

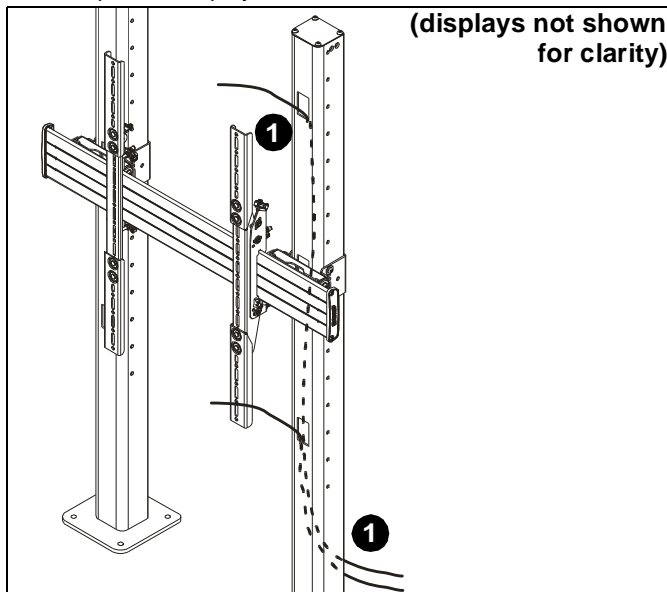

Figure 14

Additional Cable Management Options

2. Cables may be routed through tops of columns and out through the back cable management hole. (See Figure 15)

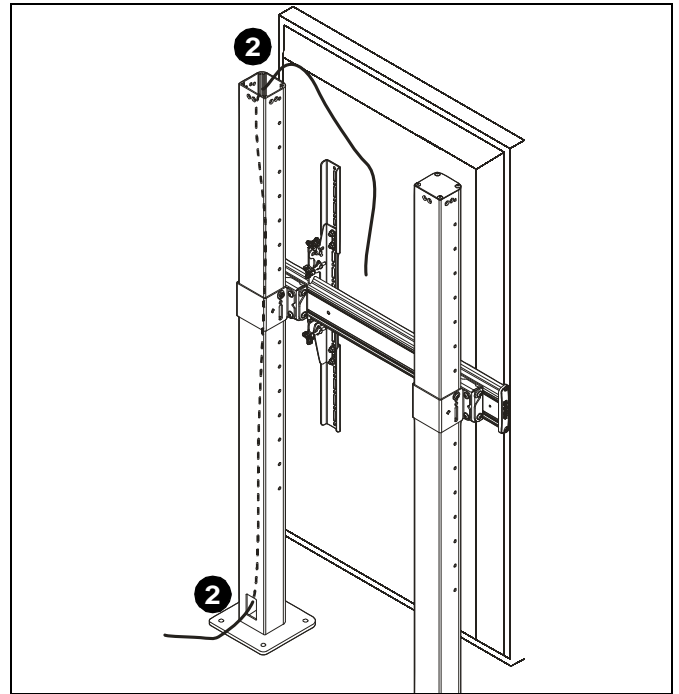

Figure 15

3. For any cable management holes that are not used, snap covers (Y) may be used to cover holes as desired. (See Figure 16)

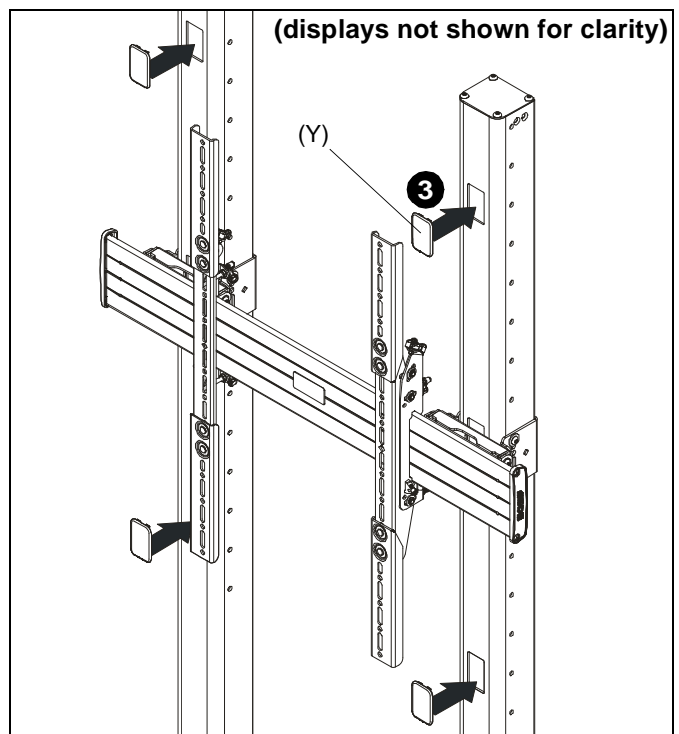

Figure 16



Our Mounts. **Your Vision.**

Chief, a products division of
Milestone AV Technologies

8800-002674 Rev00
©2015 Milestone AV Technologies
www.chiefmfg.com
02/15

USA/International	A 6436 City West Parkway, Eden Prairie, MN 55344 P 800.582.6480 / 952.225.6000 F 877.894.6918 / 952.894.6918
Europe	A Franklinstraat 14, 6003 DK Weert, Netherlands P +31 (0) 495 580 852 F +31 (0) 495 580 845
Asia Pacific	A Office No. 918 on 9/F, Shatin Galleria 18-24 Shan Mei Street Fotan, Shatin, Hong Kong P 852 2145 4099 F 852 2145 4477

