



INSTRUCTION BOOK FOR
Cosmopolitan Electrol
For Sizes Up To 9' x 12'



Original Instructions

Disclaimer

Milestone and its affiliated corporations and subsidiaries (collectively "Milestone"), intend to make this manual accurate and complete. However, Milestone makes no claim that the information contained herein covers all details, conditions or variations, nor does it provide for every possible contingency in connection with the installation or use of this subject to change without notice or obligation of any kind. Milestone makes no representation of warranty, expressed or implied, regarding the information contained herein. Milestone assumes no responsibility for accuracy, completeness or sufficiency of the information contained in this document.

Da-Lite® is a registered trademark of Milestone AV Technologies. All rights reserved.

Important Safety Instructions

When using your video equipment, basic safety precautions should always be followed, including the following:

1. Read and understand all instructions before using.
2. Maximum surrounding air temperature 122°F (50°C).
3. Main disconnect must be incorporated in the fixed wiring in accordance with the wiring rules.
4. Rated for indoor use only.
5. Use copper rated conductors rated 167°F (75°C) or higher.
6. If the supply cord is damaged, it must be replaced by the manufacturer, its service agent or similarly qualified persons in order to avoid hazard.
7. Supplied drive is only intended for use in Da-Lite screen models Advantage, Contour, and Cosmopolitan.
8. Position the cord so that it will not be tripped over, pulled, or contact hot surfaces.
9. If an extension cord is necessary, a cord with a current rating at least equal to that of the appliance should be used. Cords rated for less amperage than the appliance may overheat.
10. To reduce the risk of electric shock, do not disassemble this appliance. Contact an authorized service dealer when repair work is required. Incorrect reassembly can cause electric shock when the appliance is used subsequently.
11. The use of an accessory attachment not recommended by the manufacturer may cause a risk of fire, electric shock, or injury to persons.
12. Failure to provide adequate structural strength for this component can result in serious personal injury or damage to equipment! It is the installer's responsibility to make sure the structure to which this component is attached can support the weight of all equipment. Reinforce the structure as required before installing the component.
13. Use this projection screen only for its intended use as described in these instructions. Do not use attachments not recommended by the manufacturer.

Save These Instructions

Pre-Installation

1. Carefully unpack screen and remove outer wrapping from case.
2. Do not remove black tape or rubber bands from slat pocket.
3. Always handle screen in horizontal position.

Installation

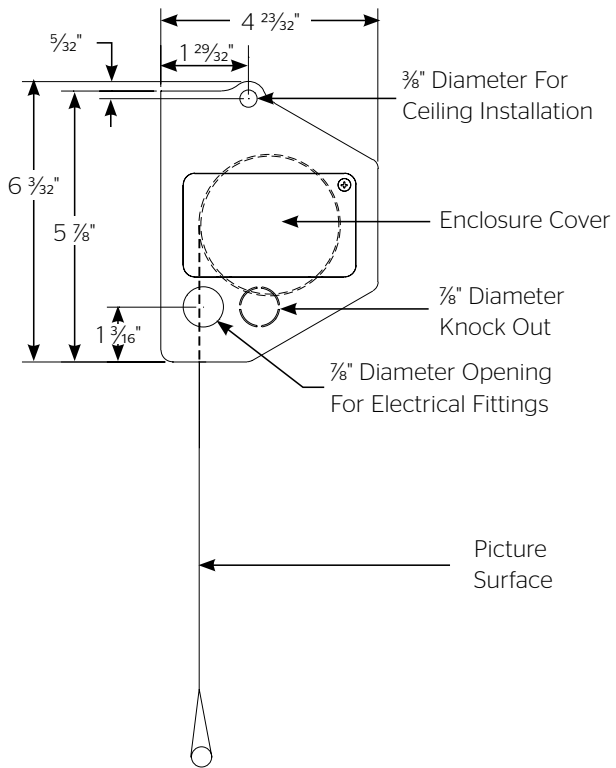
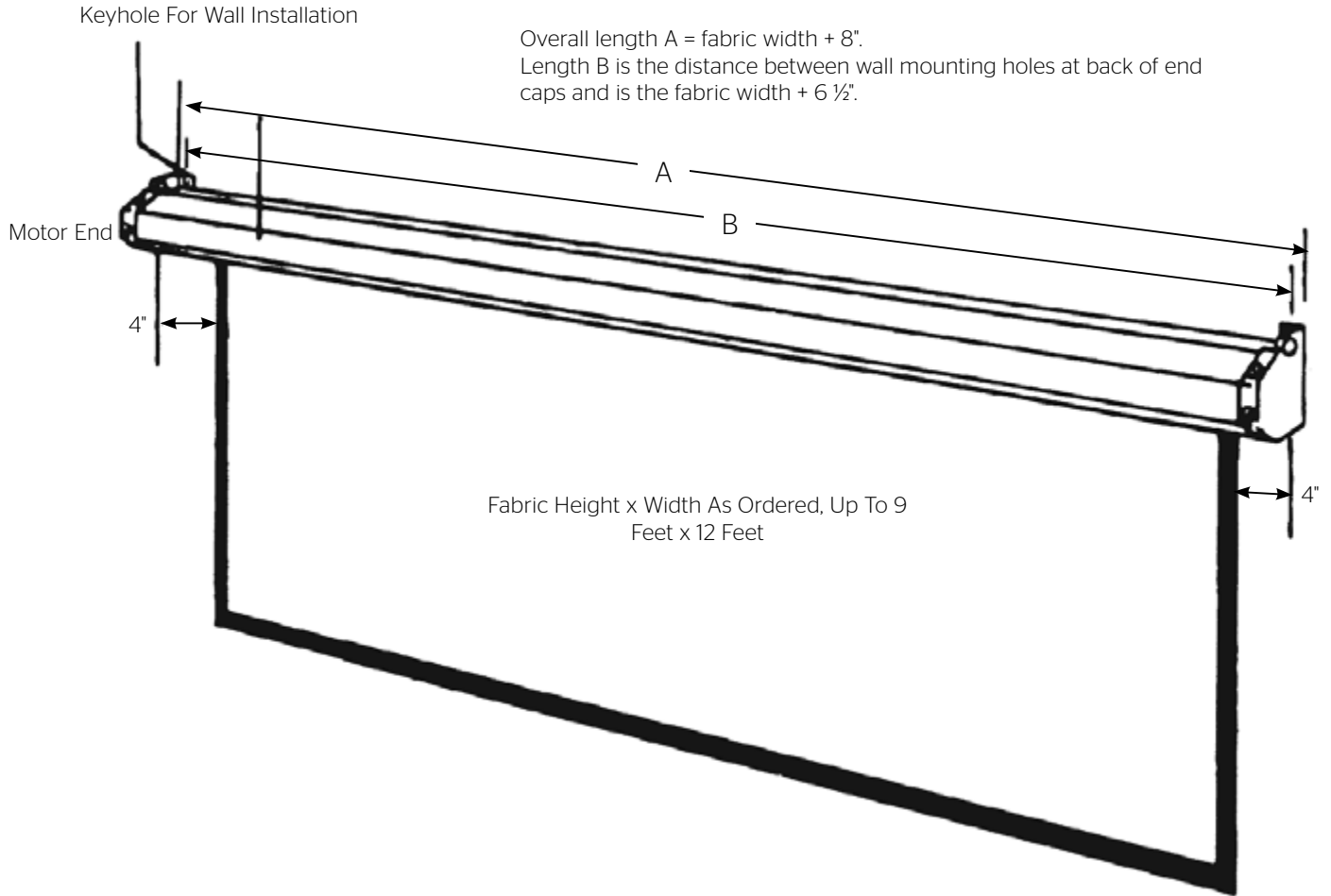

Installation Continued

NOTE: Under no circumstances should unit be completely sealed in recessed installation. Allow access for service. Picture surface is centered in case. Case extends 4" beyond surface on either end. Do not attach anything to screen slat rod or bottom fabric pocket.

1. Make sure screen is level. Use a carpenter's level and plumb level.
2. Remove tape and rubber bands from slat pocket.

⚠ CAUTION! Do not cut wrapping paper or tape with knife or any sharp tool. Remove by hand.

⚠ ATTENTION! Ne coupez pas le papier d'emballage ou le ruban adhésif avec un couteau ou un outil tranchant. Retirez à la main.

3. Install electrical hook up that applies to your unit. Make sure to review your Electrical Installation Checklists and wiring diagrams (included) for either 120 volt switch, 220/240 volt switch, or low voltage control.
4. Test installation by running screen up and down a few times. Be prepared to stop screen. Standard Duty Cycle:
1 MIN. ON / 3 MIN. OFF.

NOTE: Must be installed in accordance with the requirements of the Local Building Codes, the Canadian Electrical Code (CEC), CAN/CSA C22.1 and the National Electric Code (NEC), NFPA 70.

NOTE: DO NOT clean end caps with any cleaning solution. Use only damp cloth to clean dust from screen case.

Installation (continued)

Screen may be mounted on a wall, suspended from ceiling or extension brackets. Wall screens must be mounted level and with the case-back parallel to the wall.

Wall Mounting

1. Select fasteners of proper type for wall or ceiling involved.
2. Insert fasteners through proper openings provided in back side of end caps. See figure 1.

NOTE: DO NOT over tighten fasteners or damage may occur.

3. Attach screen securely to studding or other solid surface - never to plaster only.
4. MAKE SURE SCREEN IS MOUNTED LEVEL.

Ceiling Mounting

1. Heavy screw hooks may be installed into wood joists. Other types of hooks or chain may be used for other ceilings or for stage installations.
2. Insert hooks or chain through proper openings provided in sides of end caps. Screen must hang so that flat back of case is perpendicular to floor.

NOTE: DO NOT hang from the end caps at an angle. See Figure

3. Must be perpendicular to the mounting See Figure 4.
3. MAKE SURE SCREEN IS MOUNTED LEVEL.

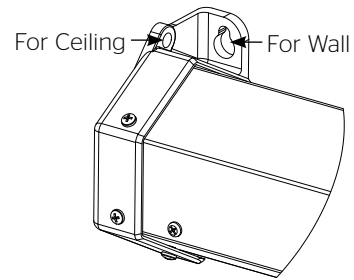

Figure 1

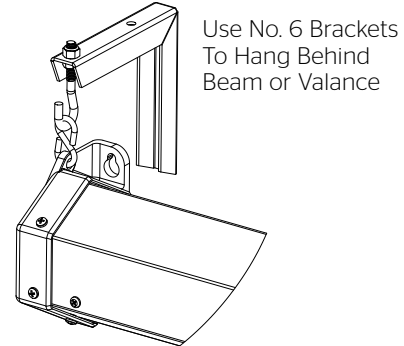

Figure 2

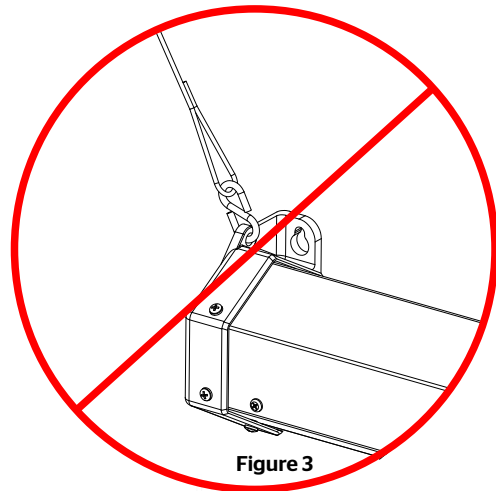

Figure 3

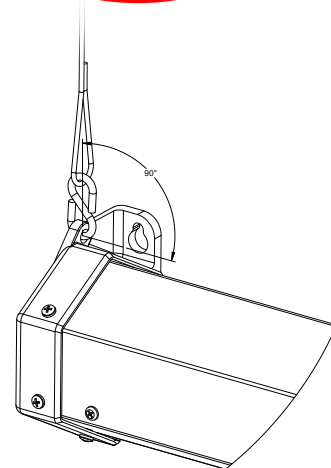
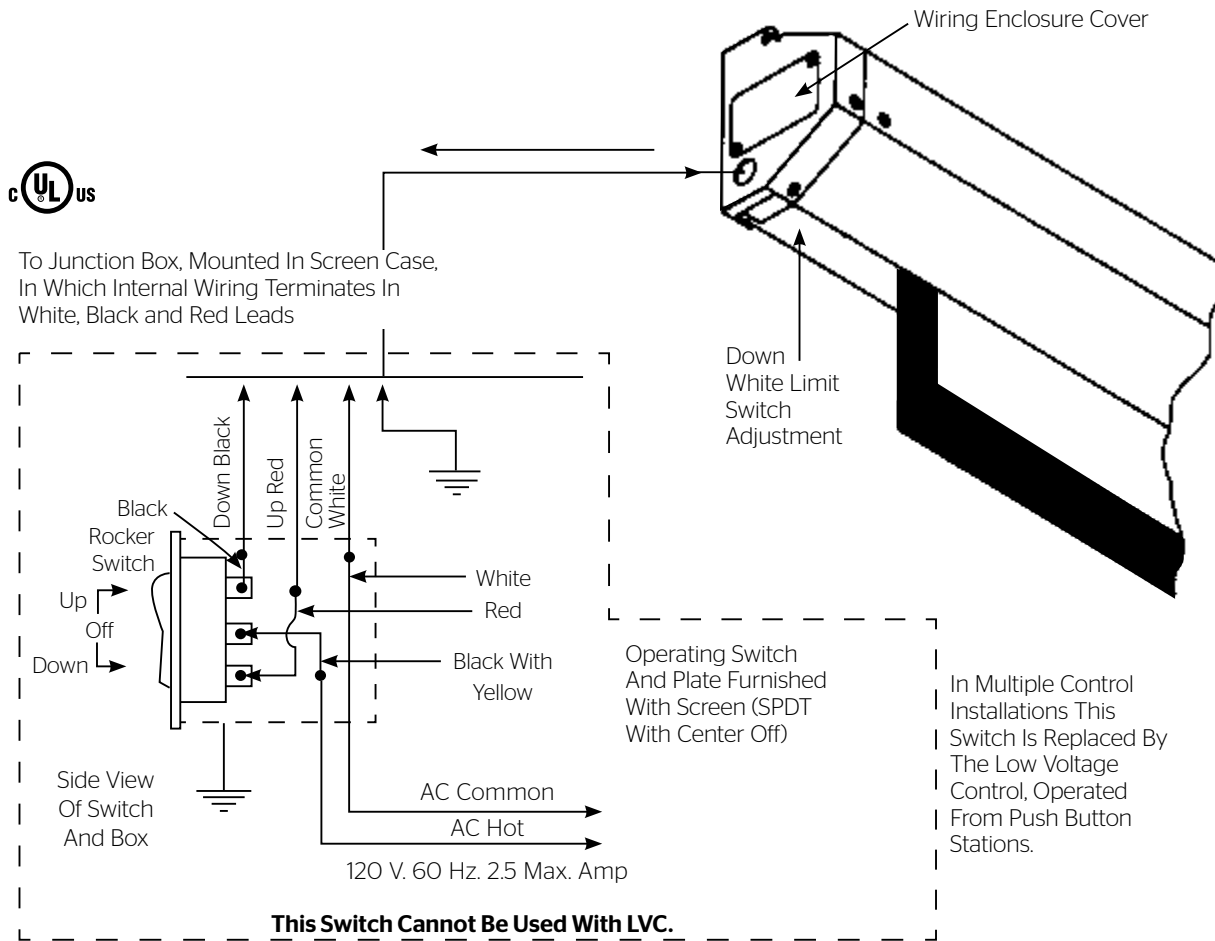

Figure 4

120V Wiring Diagram

NOTE: A single switch cannot be used to operate more than one screen. Contact the factory for further information.



120V Wiring Diagram with Optional Built-In Low Voltage Control

3-conductor 20-24 gauge wire can be used in place of the supplied RJ-14 cable to connect the wall switch. Connect the BUS terminals on the wall switch to the corresponding BUS terminals on the splitter board.

IMPORTANT NOTE: The wall switch is REQUIRED to make any limit switch adjustments, EVEN if a third party control system is used. Therefore, it is advised to wire the switch or provide a 3-conductor connection that is accessible.

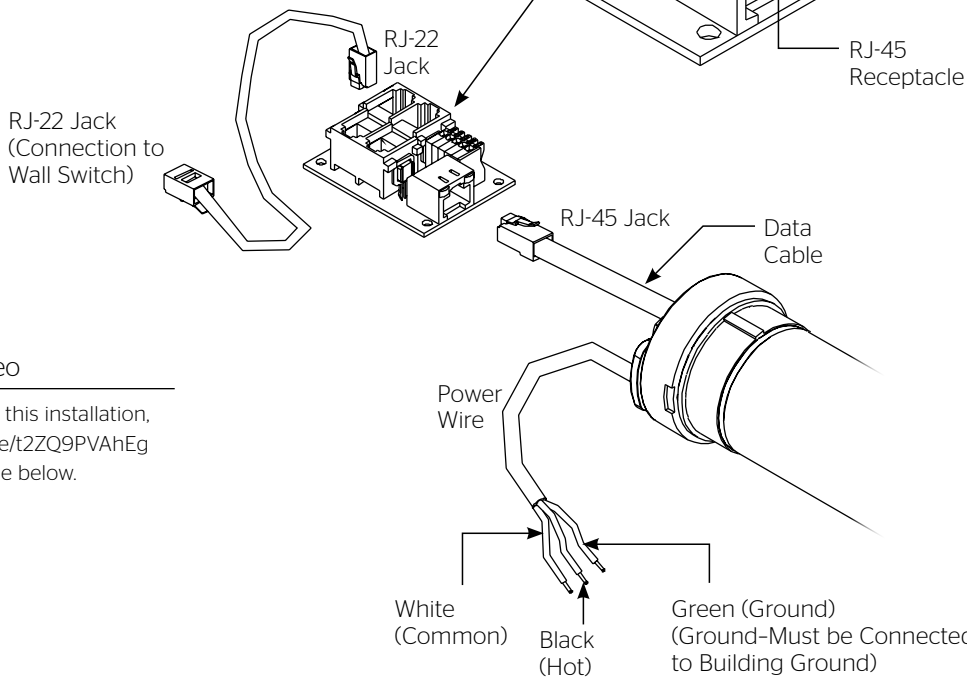
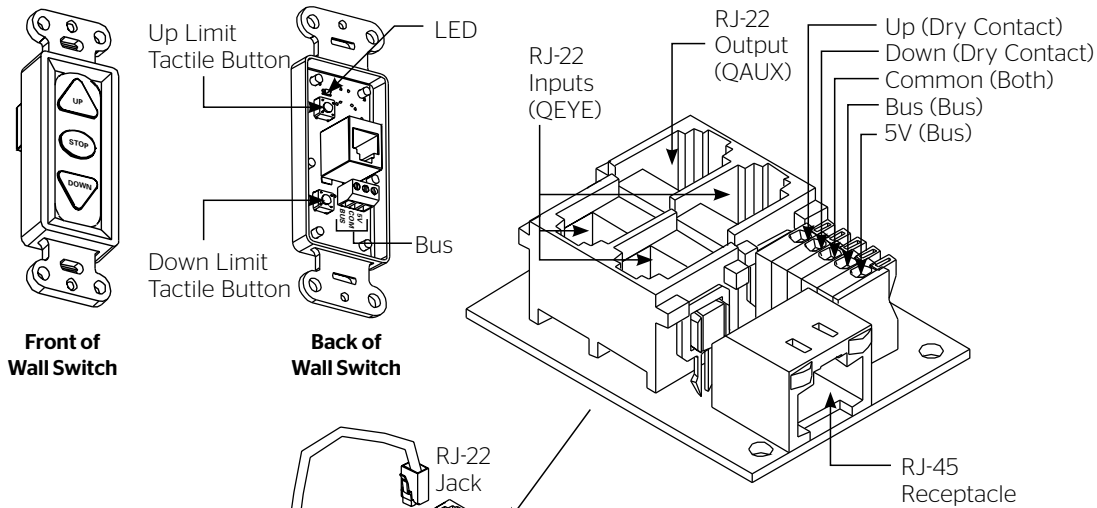

Installation Video

To view a video of this installation, visit <http://youtu.be/t2ZQ9PVAhEg> or use the QR code below.



Power Input 120VAC / 60Hz

RJ-14 Pin-Outs (Tab Is Facing Down)



Supplied RJ-14 cable

RJ-22 Pin-Outs (Tab Is Facing Down)

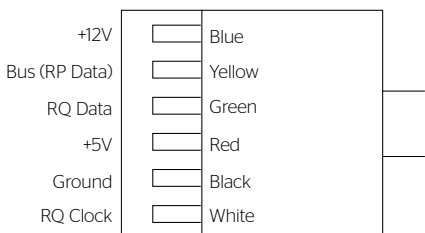

Standard RJ-22 can be used in place of RJ-14 cable

RJ-45 Pin-Outs (Tab Is Facing Down)

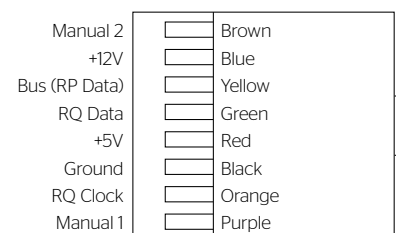

220V Wiring Diagram - Rocker Switch

NOTE: A single switch cannot be used to operate more than one screen. In multiple control installations this switch is replaced by the low voltage control, operated from push button stations. Contact the factory for further information.

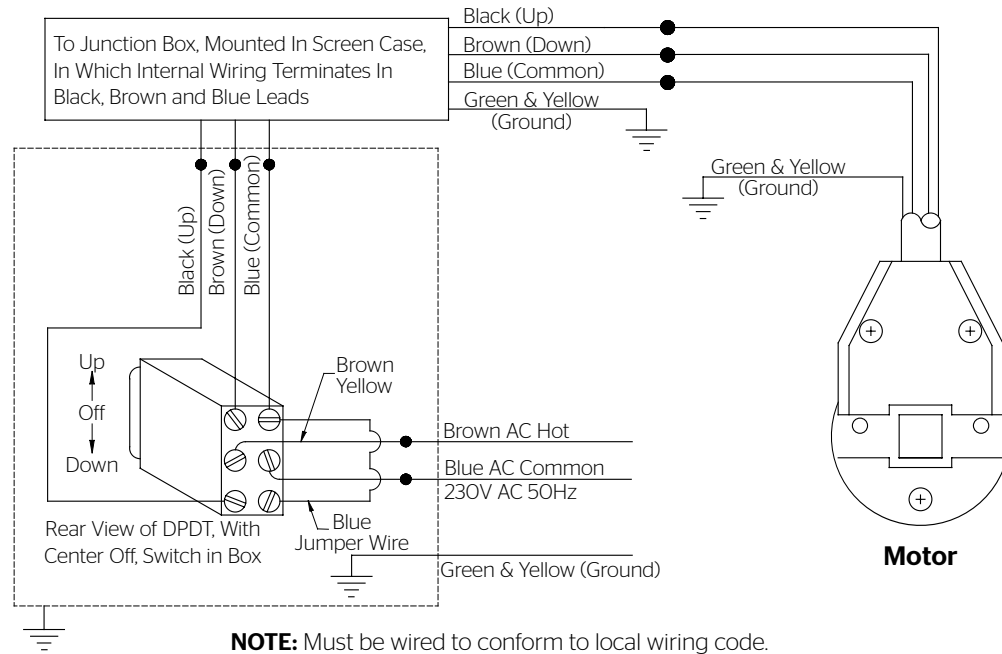

This Switch Cannot Be Used With LVC.

220V Wiring Diagram - European Switch

NOTE: A single switch cannot be used to operate more than one screen. In multiple control installations this switch is replaced by the low voltage control, operated from push button stations. Contact the factory for further information.

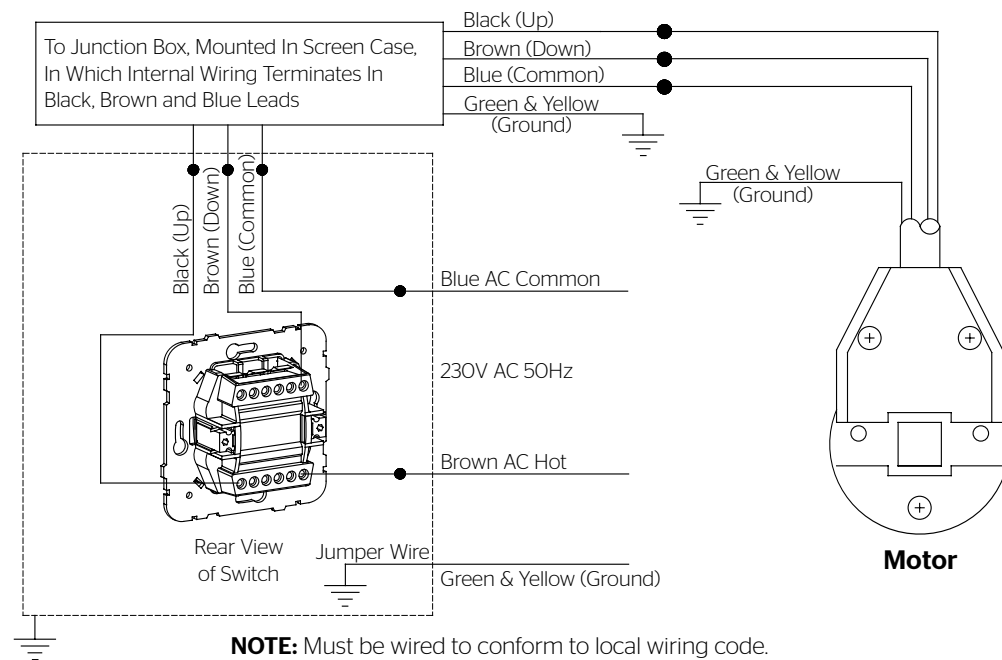

This Switch Cannot Be Used With LVC.

220V Wiring Diagram with Optional Built-In Low Voltage Control

220V Wiring Diagram with Operation & Limit Adjustment Wall Switch

3-conductor 20-24 gauge wire can be used in place of the supplied RJ-14 cable to connect the wall switch. Connect the BUS terminals on the wall switch to the corresponding BUS terminals on the splitter board.

IMPORTANT NOTE: The wall switch is REQUIRED to make any limit switch adjustments, EVEN if a third party control system is used. Therefore, it is advised to wire the switch or provide a 3-conductor connection that is accessible.

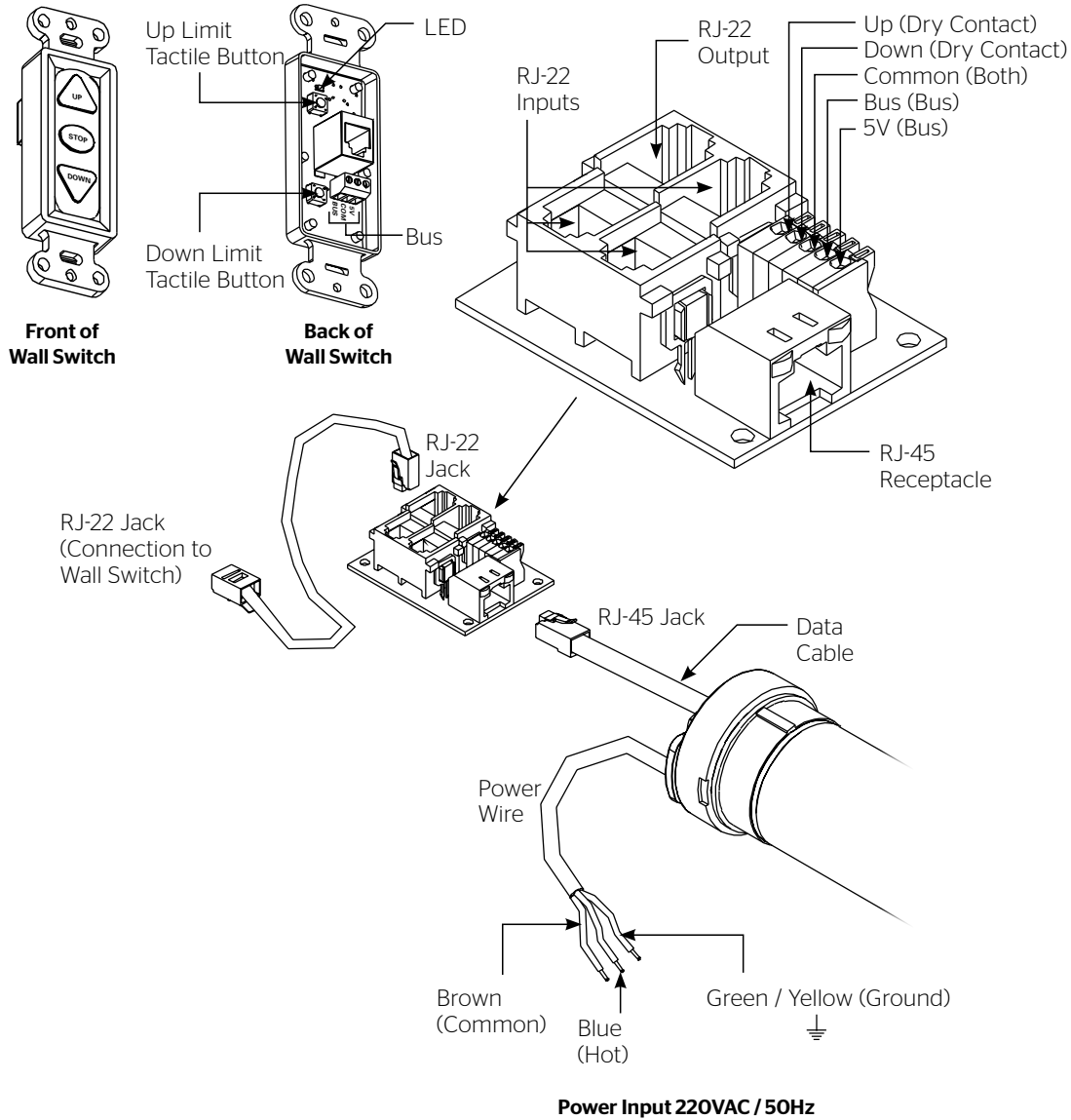

RJ-14 Pin-Outs (Tab Is Facing Down)

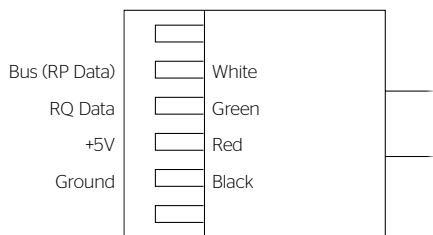

Supplied RJ-14 cable

RJ-22 Pin-Outs (Tab Is Facing Down)

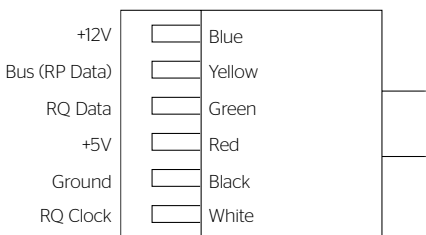

Standard RJ-22 can be used in place of RJ-14 cable

RJ-45 Pin-Outs (Tab Is Facing Down)

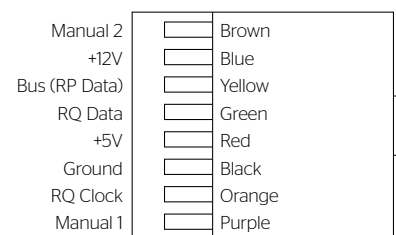

220V Wiring Diagram with Optional Built-In Low Voltage Control (continued)

220V Wiring Diagram with European Style Wall Switch

Use 3-conductor 20-24 gauge wire for wall switch connections.

IMPORTANT NOTE: The European style wall switch is for operation only and CANNOT be used to make limit switch adjustments. Therefore, it is advised to wire the limit adjustment switch or provide a 3-conductor connection that is accessible.

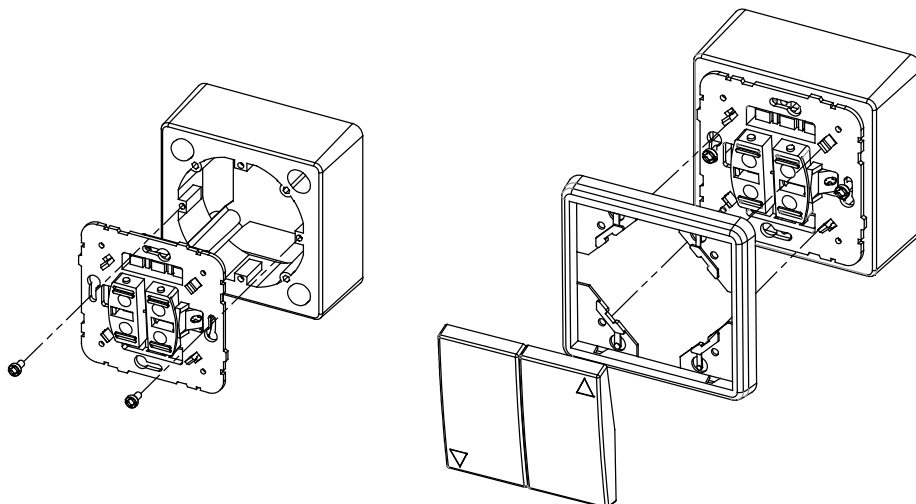
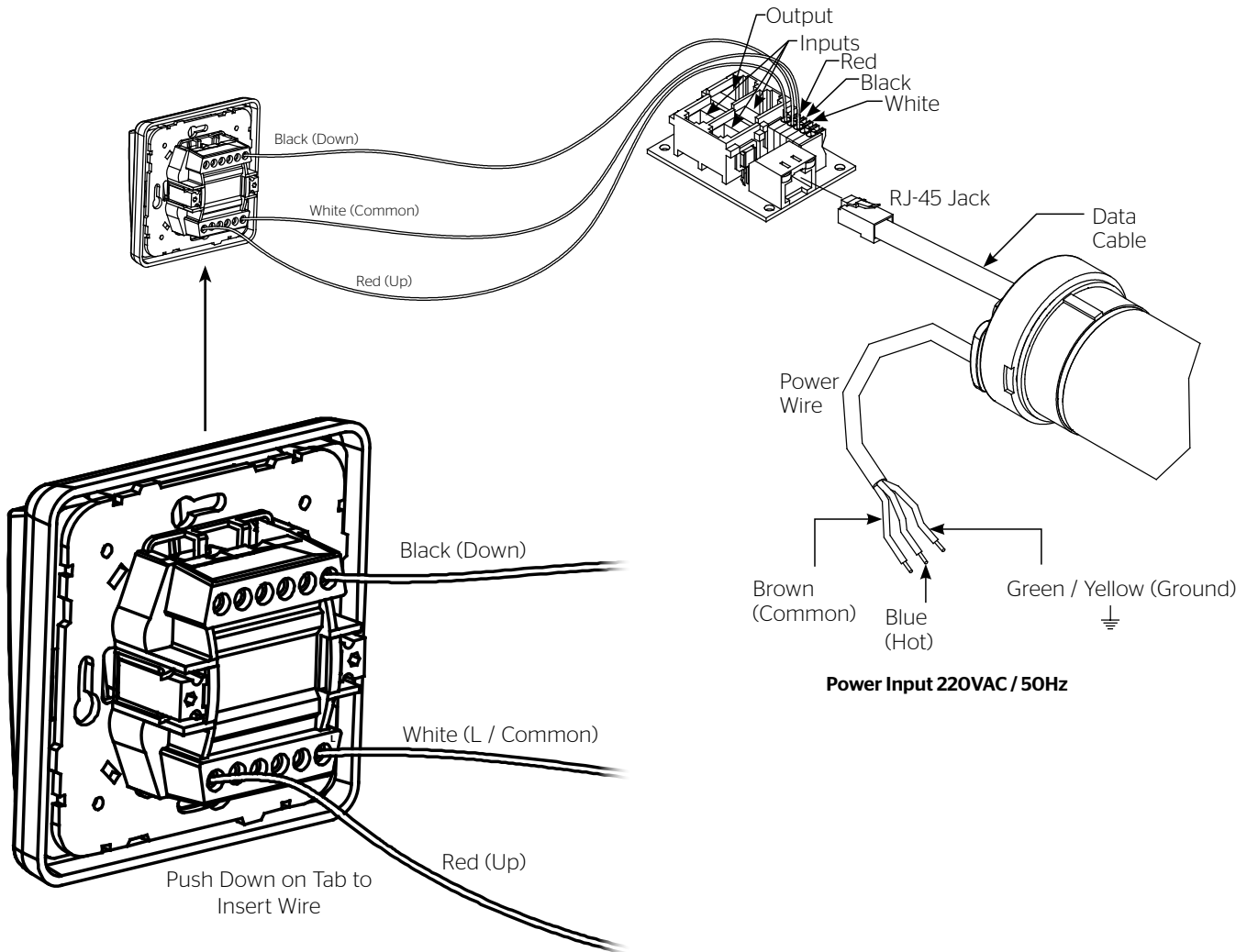

Optional Built-In Video Projector Interface

⚠ CAUTION: The projector must be turned off before connecting the trigger wires to the projector. Failure to do so may damage the controller.

⚠ ATTENTION: Le projecteur doit être éteint avant de brancher les fils de déclenchement à celui-ci. Tout manquement à cette instruction pourrait endommager le contrôleur.

Use 2-conductor 18-24 gauge wire to extend the low voltage connection from the projector's 5 or 12-volt screen trigger output to the length required to reach the VPI.

NOTE: When extending the low voltage connection from the projector's screen trigger output polarity does not matter. **The red and black wires from the VPI are interchangeable.**

IMPORTANT NOTE: The wall switch is REQUIRED to make any limit switch adjustments, EVEN if a third party control system is used. Therefore, it is advised to wire the switch or provide a 3-conductor connection that is accessible.

3-conductor 20-24 gauge wire can be used in place of the supplied RJ-14 cable to connect the wall switch. Connect the BUS terminals on the wall switch to the corresponding BUS terminals on the splitter board.

See 120V or 220V wiring diagram with built-in low voltage control for complete wiring instructions.

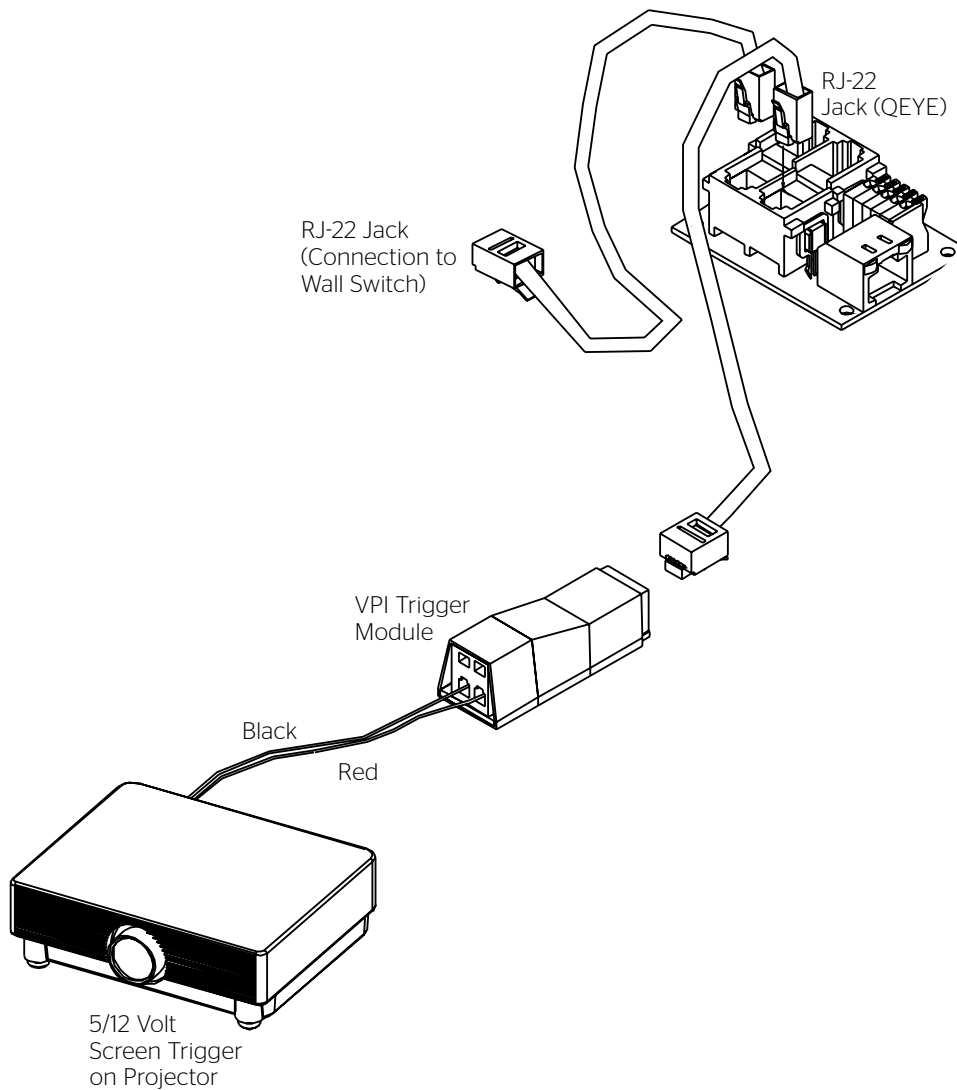

Screen Adjustment

Surface travel is stopped automatically in the fully opened and closed positions by limit switches that are properly adjusted at Da-Lite. Should it be necessary to adjust for more or less picture drop (viewing area), proceed in the following manner:

▲ CAUTION: Do not adjust for more drop than what was ordered. At least 1-1/2 wraps of fabric must remain on the roller. This screen comes standard with 0" or 2" black at the top. See the specification data sheet for details.

▲ ATTENTION! N'effectuez pas de réglage pour obtenir un déroulement supérieur à celui commandé. Au moins 1 à 1/2 tour de toile doit être maintenu sur le cylindre. Cet écran est doté de série d'une bande noire supérieure de 0 cm (0 po) ou 5 cm (2 po). Consultez la fiche technique pour plus de renseignements.

For Screens Without A Built-In Low Voltage Control

NOTE: Use a screwdriver or 5/32" Allen wrench to make adjustments.

SETTING THE DOWN LIMIT POSITION

To Reduce Screen Drop: Turn the white limit switch screw clockwise to decrease the amount of screen drop. Run the screen down to test the stop position. If the screen drops too far, raise the screen about one foot and adjust the limit switch again. Repeat until the desired position is set.

To Increase Screen Drop: Turn the white limit switch screw counterclockwise to increase the amount of screen drop. Run the screen down to test the stop position. If the screen does not drop enough, raise the screen about one foot and adjust the limit switch again. Repeat until the desired position is set. Do not adjust for more drop than what was ordered. At least 1-1/2 wraps of fabric must remain on the roller.

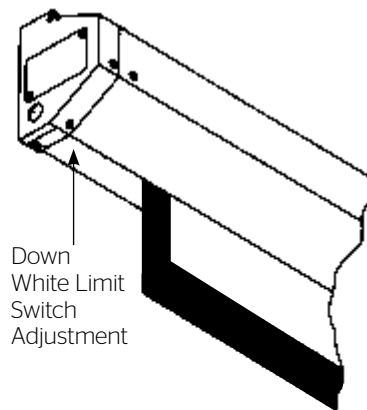

Screen Adjustment (continued)

For Screens With A Built-In Low Voltage Control or VPI

1. Locate the wall switch and remove the cover plate from the 3-button wall switch and remove the switch from the junction box.
2. Locate the two tactile buttons on the back of the switch. They are square silver with black round buttons.
3. To adjust the down limit switch, press and hold the down tactile button until the LED on back of switch turns solid red. This will put the motor in limit set mode. Turn the wall switch over and use the down button on front of switch. Press and hold until the desired travel position is reached. If you travel to far down you can press the up to move the screen upward. If you press and let go of either up or down button the motor will do a small jog in that direction for finer adjustment of screen. Once desired position is reached turn switch over press and hold down tactile button until the LED on back of switch blinks red twice. The down limit is now set.
4. To adjust the up limit switch, press and hold the up tactile button until the LED on back of switch turns solid green. This will put the motor in limit set mode. Turn the wall switch over and use the up button on front of switch. Press and hold until

the desired travel position is reached. If you travel to far up you can press the down to move the screen downward. If you press and let go of either up or down button the motor will do a small jog in that direction for finer adjustment of screen. Once desired position is reached turn switch over press and hold up tactile button until the LED on back of switch blinks green twice. The up limit is now set.

5. To test limit switch setting, press and release the up or down button on the wall switch to operate the screen.
6. Replace switch and cover plate on the wall.

NOTE: If the screen is in limit set mode and no buttons are pushed for 20 seconds, the LED on the back of the wall switch will turn off, the motor will return to run mode and no changes will be saved. If this occurs, return to step 3 for down limit adjustment or step 4 for up limit adjustment.

IMPORTANT NOTE: The wall switch is REQUIRED to make any limit switch adjustments, EVEN if a third party control system is used. Therefore, it is advised to wire the switch or provide a 3-conductor connection that is accessible.

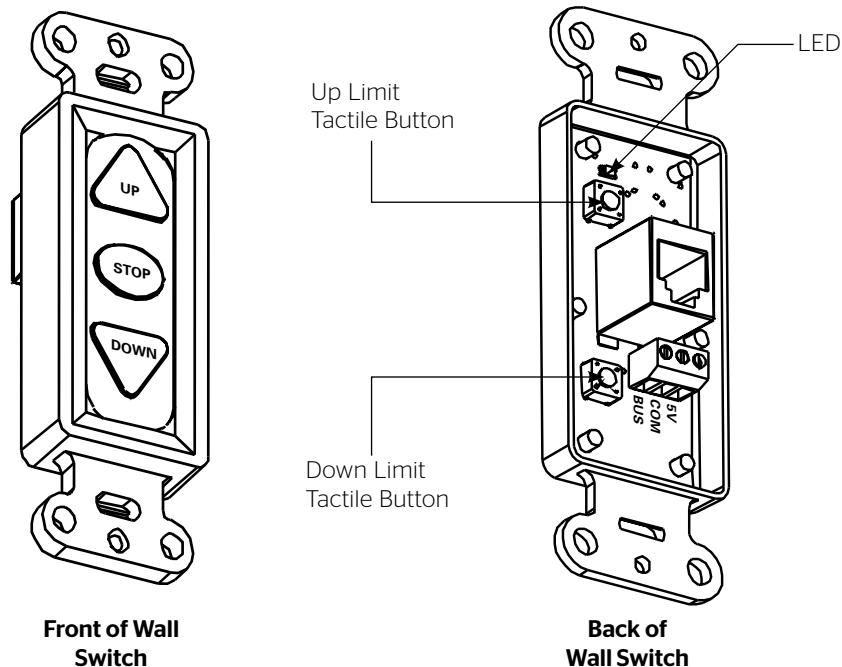

Operation of Screens With A Built-In Low Voltage Control or VPI

Operation & Limit Adjustment Wall Switch

1. Press "DOWN" button on screen switch and screen will deploy out of case in downward direction.
2. Press "STOP" button on screen switch and screen will stop if in movement.
3. Press "UP" button on screen switch and screen will retract upward into case.

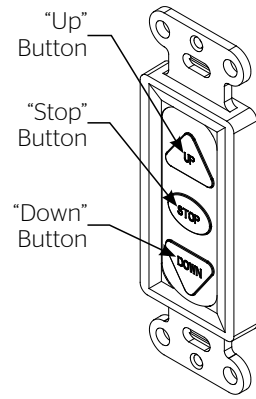

European Style Wall Switch (220V models only)

1. Press "DOWN" button on screen switch and screen will deploy out of case in downward direction.
2. Press "UP" button on screen switch and screen will retract upward into case.

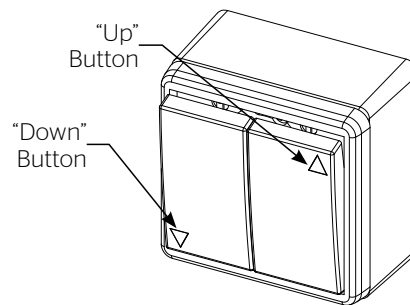

Third Party Control For Screens With A Built-In Low Voltage Control or VPI

Control Panel

A control panel may be connected to the splitter board by using the dry contact Up, Down and Common connections. The control panel must provide a momentary, dry contact closure of at least 1/2 second.

1. Use 3-conductor 20-24 gauge wire to connect the control panel to the splitter board.
2. A momentary closure across the common and up wires will be an "up" command.
3. A momentary closure across the common and down wires will be a "down" command.
4. A momentary closure across the common, up and down wires will be a "stop" command.

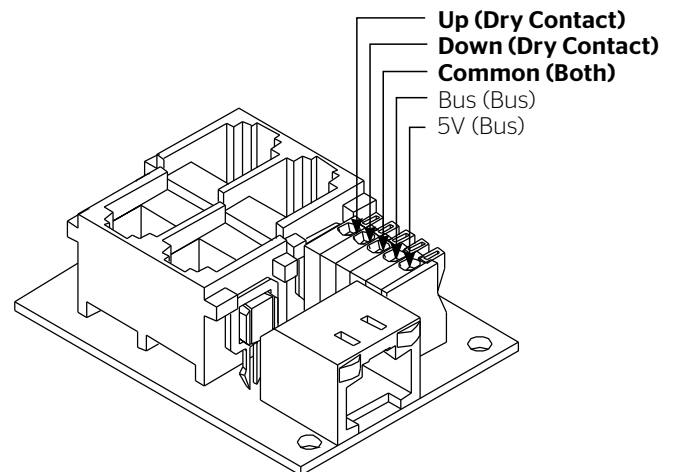

Troubleshooting

Symptom	Cause	Solution	
Screen will not operate. Motor does not hum.	Incorrect line voltage.	Verify 115-125V (or 220-240V). If insufficient voltage, rewire incoming electric line.	
	Blown fuse.	Replace fuse.	
	Tripped circuit breaker.	Reset circuit breaker.	
	No power to operating switch or junction.		Check above. Tighten all loose wire connections. Correct any improper connections. "Down" Position Check for power across black and white leads.
			"Up" Position Check for power across red and white leads.
	Power at junction box. Thermal overload tripped.	Let motor cool down for 15 minutes. Try again.	
	Broken wire in the "up" or "down" position.	Check for continuity. Cut off old splice and reconnect.	
Motor hums.	Defective motor, limit switch or capacitor..	Replace motor assembly. NOTE: Motor is a sealed assembly..	
	Capacitor burned out.	Replace motor assembly.	
Incorrect stopping position in downward direction.	Lost roller wrap.	See instructions below.	
	"Down" limit switch out of adjustment.	See installation instructions.	
Incorrect stopping position in upward direction.	Lost roller wrap.	See instructions below.	
	"Up" limit switch out of adjustment.	Adjust "up" limit switch. Call factory for instructions.	
Noise. NOTE: Screen will operate with a low pitched hum.	Gear noise.	Replace motor assembly.	
Coasting.	Defective brake.	Replace motor assembly.	
Roller displaced from mounting bracket.	Pin end slipped out of nylon bearing.	Realign pin end bracket.	

Restoring Lost Roller Wrap

1. Push strap over back of roller.
2. Tape end of strap to pocket.
3. Feed fabric as you pull strap to draw fabric over top.
4. Remove tape and strap.

LIMITED ONE YEAR WARRANTY ON DA-LITE PRESENTATION PRODUCTS

Milestone AV Technologies LLC warrants certain Da-Lite branded products to the original purchaser only, to be free from defects in materials and workmanship for a period of one (1) year from the date of purchase by the original purchaser; provided they are properly operated according to Da-Lite's instructions and are not damaged due to improper handling or treatment after shipment from the factory.

This warranty does not apply to equipment showing evidence of misuse, abuse or accidental damage, or which has been tampered with or repaired by a person other than authorized Da-Lite personnel.

Da-Lite's sole obligation under this warranty shall be to repair or to replace (at Da-Lite's option) the defective part of the merchandise. Returns for service should be made to your Da-Lite dealer. If it is necessary for the dealer to return the screen or part to Da-Lite, transportation expenses to and from Da-Lite are payable by the purchaser and Da-Lite is not responsible for damage in shipment. To protect yourself against damage or loss in transit, insure the product and prepay all transportation expenses.

TO THE MAXIMUM EXTENT PERMITTED BY APPLICABLE LAW, THIS WARRANTY IS IN LIEU OF ALL OTHER WARRANTIES, EXPRESS OR IMPLIED, INCLUDING WARRANTIES AS TO FITNESS FOR USE AND MERCHANTABILITY. Any implied warranties of fitness for use, or merchantability, that may be mandated by statute or rule of law are limited to the one (1) year warranty period. This warranty gives you specific legal rights, and you may also have other rights, which vary from state-to-state. **TO THE MAXIMUM EXTENT PERMITTED BY APPLICABLE LAW, NO LIABILITY IS ASSUMED FOR EXPENSES OR DAMAGES RESULTING FROM INTERRUPTION IN OPERATION OF EQUIPMENT, OR FOR INCIDENTAL, DIRECT, OR CONSEQUENTIAL DAMAGES OF ANY NATURE.**

In the event that there is a defect in materials or workmanship of a Da-Lite product, you may contact our Customer Care Specialists at 3100 North Detroit Street, Warsaw, IN 46582, (574) 267-8101, (800) 622-3737.

IMPORTANT: THIS WARRANTY SHALL NOT BE VALID AND DA-LITE BRANDED PRODUCTS SHALL NOT BE BOUND BY THIS WARRANTY IF THE PRODUCT IS NOT OPERATED IN ACCORDANCE WITH THE DA-LITE WRITTEN INSTRUCTIONS.

Keep your sales receipt to prove the date of purchase and your original ownership.



A BRAND OF MILESTONE AV TECHNOLOGIES | www.milestone.com

P 800.622.3737 / 574.267.8101 **F** 877.325.4832 / 574.267.7804

E info@da-lite.com

In British Columbia, Milestone AV Technologies ULC carries on business as MAVT Milestone AV Technologies ULC.

©2018 Milestone AV Technologies. DL-0256 (Rev. 3) 0418.

Da-Lite is a registered trademark of Milestone AV Technologies. All other brand names or marks are used for identification purposes and are trademarks of their respective owners. All patents are protected under existing designations. Other patents pending.