

PRESET 10 ARCHITECTURAL OWNERS MANUAL

Doug Fleenor Design
396 Corbett Canyon Road
Arroyo Grande, CA 93420
(805) 481-9599

PRODUCT DESCRIPTION

The *Preset 10 Architectural* is a lighting control station capable of storing up to ten presets. These presets are recorded by capturing the output of a DMX512 console. Each preset can then be assigned a unique fade time, from 0 to 999 seconds. Presets are recalled by pressing one of the buttons.

Systems can be created by using one or more stations and a power supply. The solid aluminum faceplate is designed to install over a standard single gang electrical box. Connections to the *Preset 10 Architectural* are power (2 wires) and DMX512 (3 wires). Power for the *Preset 10* can be supplied from a variety of sources, including a 10V class 2 "doorbell" transformer.

The *Preset 10 Architectural* system can work in conjunction with a lighting console, automatically switching between preset and console control. When the console generates a DMX512 signal the *Preset 10 Architectural* goes off-line. The console then operates normally. Upon loss of DMX512 from the console, the *Preset 10 Architectural* either returns to its pervious preset or holds the last look (jumper selectable).

The *Preset 10* system also comes in a portable version (model PRE10-P) that acts as a backup station for any DMX512 lighting console or as a stand-alone DMX512 preset console.

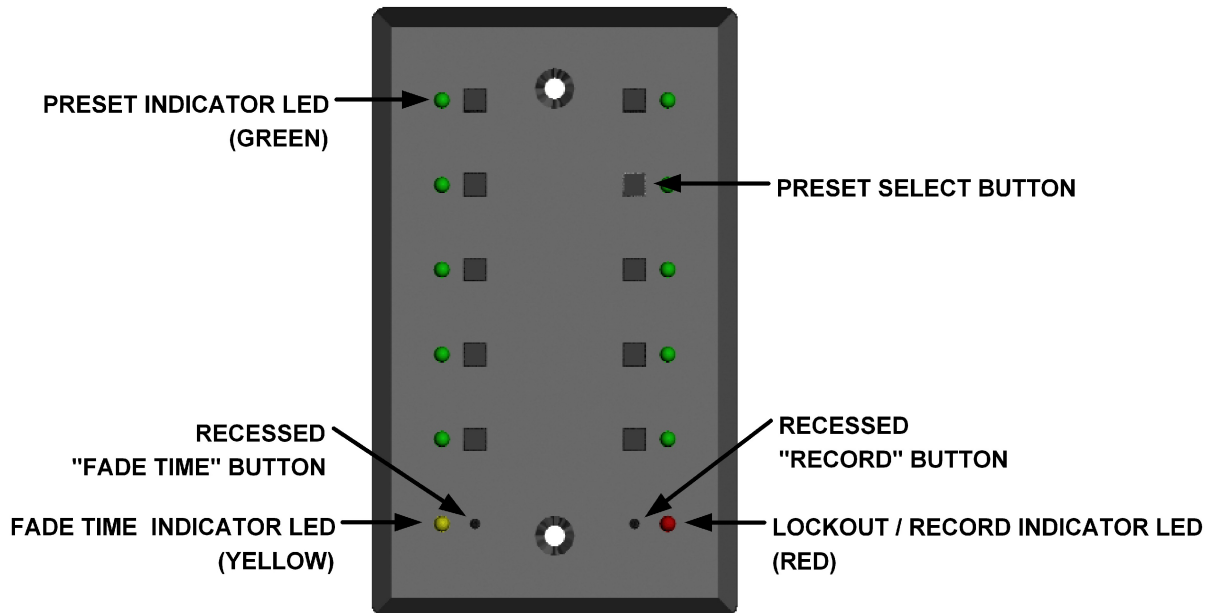

SPECIFICATIONS

Connector: Phoenix Contact MSTB series 5 position two part terminal block
 Model: MSTB 2,5/5-ST-5,08 Order Number: 17 57 04 8

Connector pin out:
 (V) Supply voltage "hot"
 (C) Supply common (internally tied to DMX512 common)
 (+) DMX512 data +
 (-) DMX512 data -
 (C) DMX512 common

Input/Output Circuit: ESD protected EIA-485 transceiver (LT1785)

Indicators:
 Ten green preset indicator LEDs
 One yellow Fade Time LED
 One red Signal / Record LED

User controls:
 Ten preset push buttons
 One recessed record push button
 One recessed fade time push button

Option Jumpers: For a single station installation all jumpers should be installed. (see figure 1, page 5)

	INSTALLED	REMOVED
JP1	Recording Enabled	Recording Disabled
JP2	Master Station	Slave Station
JP3	Architectural Mode	Portable Mode
JP4	Single Station Mode	Multi Station Mode

Power input: 9 to 15 volts AC or DC, 200mA per station
 (A 10 volt class 2 "doorbell" transformer is recommended for fixed installations)

Color: Black anodized with silver engraved nomenclature

Size :
 Faceplate: 4.5"h X 2.75"w X 0.2"d
 Faceplate rear inset: 4.05"h X 2.4"w X 0.1"d
 Electrical box minimum inside dimensions: 3.5"h X 2.1"w X 1.25"d

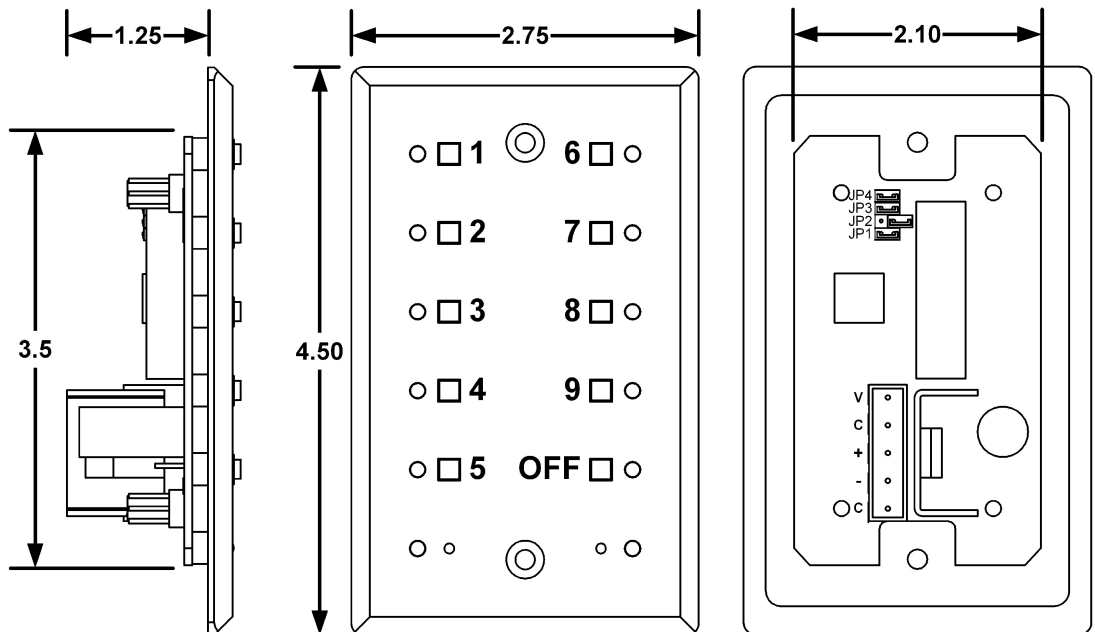

PRESET 10 ARCHITECTURAL - INSTALLATION

WIRING INFORMATION

Preset 10 Architectural is designed to use daisy-chain wiring topology. An alternative to the daisy-chain topology is the star topology. To create a star, a bidirectional isolated splitter (model BiDi8) is required. Also note that a system may contain multiple power supplies when voltage drop becomes a concern. Please give us a call if you have any questions.

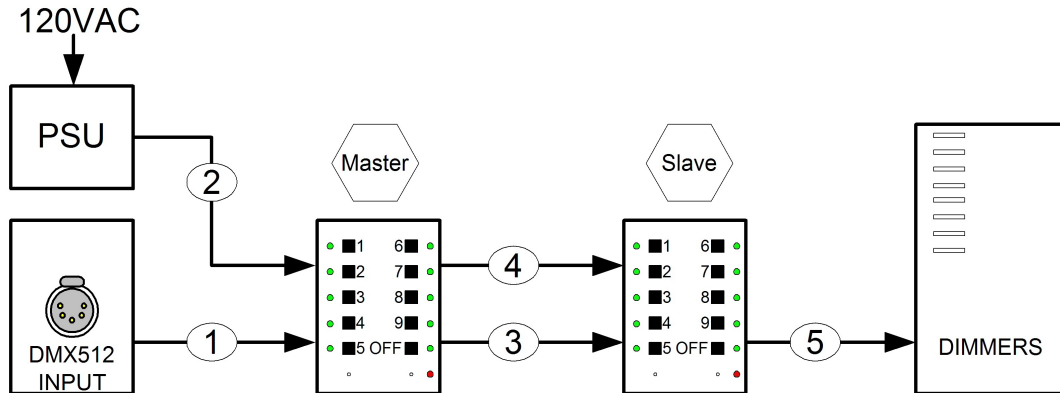

CABLE	COLOR	FROM	TO	USE
1 120 Ohm Data Cable Belden 9829 or Equivalent	Shield	5 Pin XLR Plate	Pin 1	TB1-1 Common
	White/Blue		Pin 2	TB1-2 Data -
	Blue/White		Pin 3	TB1-3 Data +
2 (2) #16 AWG Stranded Wires	Black	Power Supply	Common	TB1-4 Supply
	Red		Power	TB1-5 Supply "hot"
3 120 Ohm Data Cable Belden 9829 or Equivalent	Shield	PRE10 Master	TB1-1	TB1-1 Common
	White/Blue		TB1-2	TB1-2 Data -
	Blue/White		TB1-3	TB1-3 Data +
4 (2) #16 AWG Stranded Wires	Black	PRE10 Slave	TB1-4	TB1-4 Supply
	Red		TB1-5	TB1-5 Supply "hot"
5 120 Ohm Data Cable Belden 9829 or Equivalent	Shield	PRE10 Slave	TB1-1	? Common
	White/Blue		TB1-2	? Data -
	Blue/White		TB1-3	? Data +

POWER SUPPLY

The voltage provided to the *Preset 10 Architectural* must be between 9 and 15 volts AC or DC, 200mA per station. The *Preset 10 Architectural* has been designed to operate on a standard class 2 "doorbell" transformer.

PRESET 10 ARCHITECTURAL - SETUP

FACEPLATE CONFIGURATION

Each *Preset 10 Architectural* has four jumpers, JP1 through JP4, that select different modes of operation. The factory default is to have all jumpers installed.

- JP1** When this jumper is installed on the MASTER faceplate recording of presets is enabled. When removed, the TIME and RECORD buttons are disabled. The position of JP1 on a SLAVE faceplate has no affect.
- JP2** When this jumper is installed the faceplate takes on the MASTER duty. The MASTER faceplate is responsible for transmitting and receiving DMX512, storing presets, and communicating with SLAVE faceplates. When removed, the faceplate takes on the SLAVE duty. A SLAVE faceplate communicates button presses and mimics the state of the LEDs on the master faceplate.
- JP3** When the jumper is installed the *Preset 10* operates as an architectural preset station. When this jumper is removed the *Preset 10* operates as a console backup/portable station. This jumper modifies the personality of the *Preset 10* software.
- JP4** When this jumper is installed it enables SINGLE STATION MODE. In this mode the faceplate will not send any "alternate start code" packets. When this jumper is removed it enables MULTI STATION MODE. This allows the alternate start code packets required for master/slave station operation. If your system contains only one *Preset 10*, there is no need to remove the jumper.

MASTER AND SLAVE SELECTION

In a system with more than one faceplate only one MASTER is allowed. To modify faceplate to become a MASTER which can support SLAVE stations, the shunt located at JP2 should be installed and the shunt at JP4 should be removed. For safe keeping place the shunt over only one of the pins at JP4.

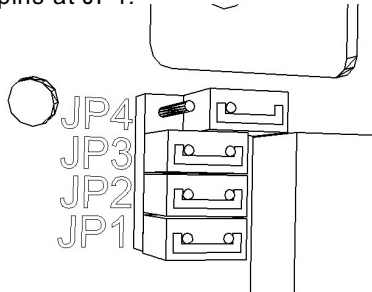

(Figure 1)

To modify a faceplate to become a SLAVE the shunts located at JP2 and JP4 should be removed. For safe keeping place the shunt over only one of the pins at JP2 and JP4.

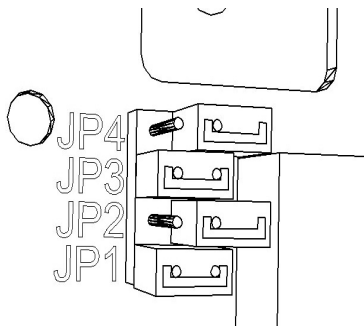

(Figure 2)

PRESET 10 ARCHITECTURAL - OPERATION

INDICATORS

GREEN LED

ON = CURRENTLY SELECTED PRESET

FLASHING = TIME SETTING MODE SELECTED FOR THIS PRESET

YELLOW LED

ON = PRESET FADE IS IN PROGRESS

FLASHING = TIME SETTING MODE SELECTED

RED LED

ON = STATION LOCKED OUT / RECEIVING DMX512 FROM EXTERNAL CONSOLE

FLASHING = RECORD MODE ACTIVE

GREEN LED	YELLOW LED	RED LED	STATE
OFF	OFF	OFF	UNIT NOT POWERED
OFF	OFF	ON	RECEIVING DMX512 <i>PRESET 10</i> IS LOCKED OUT FROM TRANSMITTING
OFF	OFF	FLASHING	RECORD MODE ACTIVE CURRENT LOOK WILL BE STORED TO THE NEXT PRESSED PRESET
FLASHING	FLASHING	OFF	TIME SETTING MODE ACTIVE FOR SELECTED PRESET
ON	OFF	OFF	<i>PRESET 10</i> TRANSMITTING DMX512 NO DMX512 INPUT
ON	ON	OFF	<i>PRESET 10</i> TRANSMITTING DMX512 CURRENTLY FADING FROM PREVIOUS PRESET

RECORDING PRESETS

In order to set the individual dimmer levels recorded to a preset, the *Preset 10* must be connected to a DMX512 source. When less than 512 dimmer levels are received, a level of 0% will be stored for all channels above those received.

Note:

- For predictable results, avoid recording when the DMX512 levels are changing.
- Recording of presets must be done from the MASTER faceplate

1. Using the primary DMX512 console, set a "look" to be recorded.
2. Using a small blunt object (i.e. paper clip), depress the RECORD MODE recessed button located next to the RED LED. The RED LED will begin to flash. If you decide after depressing the RECORD MODE button that you do not wish to make an edit, depress the RECORD MODE button a second time. No changes will have been made.
3. Depress the PRESET SELECT button adjacent to the preset number you wish to record. The adjacent GREEN LED will illuminate as you depress the button. (Example: press the upper most left button to store preset 1)
4. Upon releasing the PRESET SELECT button, the RED LED will no longer flash. This Indicates recording is complete.

Repeat steps 1 through 4 until you have recorded as many presets as required, up to ten total.

PRESET NUMBER 10 (OFF) - SPECIAL FUNCTION

When the levels stored in preset number 10(OFF) are **all zeros** a special function is enabled. When preset 10(OFF) is selected and the crossfade has completed the *Preset 10* will stop sending DMX512. By ending DMX512 transmission, many moving lights and dimming systems will enter their standby mode. This feature can be disabled by recording any non-zero level on any channel into preset number 10(OFF).

RECORDING PRESET CROSSFADE TIME

A crossfade is a fade where the new preset levels entirely replace the previous levels. Each of the ten presets can have its own unique crossfade time. Crossfade times default to two seconds.

Note:

- Crossfade times range from a minimum of 0 second to as maximum of 999 seconds(16 Min., 39 Sec.).
- Crossfade times can not be set while the *Preset 10* is locked out (red LED is illuminated).

To enter a crossfade time:

1. Disconnect the *Preset Ten* from any DMX512 source.
2. Press the button of the preset you wish to edit. The GREEN preset indicator LED will illuminate.
3. Using a small blunt object (i.e. paper clip), depress the TIME SETTING MODE recessed button located adjacent to the yellow LED indicator. The green indicator LED adjacent to the preset you selected to edit and the yellow time LED will now flash. You will have ten seconds to set the crossfade time. If you decide after depressing the TIME SETTING MODE button that you do not wish to make an edit simply wait 10 seconds or depress the TIME SETTING MODE button a second time. No changes will have been made.
4. Enter the time in seconds using the PRESET SELECT buttons. Use PRESET SELECT button 10(OFF) to enter a zero. (i.e. 120 seconds is entered by pressing PRESET SELECT button 1 followed by 2 then OFF). The time setting command is completed by one of three methods:
 - a. Enter a three-digit time. The TIME SETTING MODE will exit upon the entry of the third digit. The GREEN preset indicator LED will illuminate steadily and the yellow LED will go off indicating success. A one or two digit time may be entered with leading zeros (i.e. five seconds as 005 or OFF, OFF, 5).
 - b. Enter a one or two digit time followed by pressing the TIME SETTING MODE button. The GREEN preset indicator LED will illuminate steadily and the yellow LED will go off indicating success.
 - c. Enter a one or two digit time and wait for ten seconds for the time setting mode to exit automatically. The GREEN preset indicator LED will illuminate steadily and the yellow LED will go off indicating success.

PLAYBACK OF PRESETS

Presets can be played back in one of two ways, a crossfade to a static preset or an autofollow of all ten presets. A crossfade is a change from the current preset to the newly selected one. The time taken to fade from the current preset to the new preset is taken from the newly selected preset. Once the fade has completed, it will remain in that preset (static) until another preset is selected. When the autofollow method of playback is used, once the fade time of the currently fading preset is completed the next preset is automatically selected.

To begin a crossfade between presets momentarily press the preset select button of the preset you wish to play.

To begin autofollow of all ten presets, press and hold the preset select button of preset number 1 (approximately 5 seconds) until all the LEDs flash once. Once the fade time of a preset is complete, the next preset will be selected automatically. When preset number 10(OFF) has been reached the next preset to be selected will be preset number 1.

To exit autofollow momentarily press any preset select button.

Note:

- If a static preset is playing at the time power is lost *Preset 10* will return to that preset when power is restored. The fade will begin with all 512 channels at 0% and fade up in the time recorded to that preset.
- If the *Preset 10* was in autofollow playback at the time power was lost, the *Preset 10* will resume autofollow playback beginning with preset number 1.
- To bypass unused presets in autofollow mode, set the crossfade time for those presets to 999 seconds. This means the longest autofollow fade time is 998 seconds.

PRESET NUMBER 10 (OFF) - SPECIAL FUNCTION

When the levels stored in preset number 10(OFF) are **all zeros** a special function is enabled. When preset 10(OFF) is selected and the crossfade has completed the *Preset 10* will stop sending DMX512. By ending DMX512 transmission, many moving lights and dimming systems will enter their standby mode. This feature can be disabled by recording any non-zero level on any channel into preset number 10(OFF).