

110-120V Salara/Hardwire by Draper

⚠ Caution

- ① Read instructions through completely before proceeding.
- ② Follow instructions carefully. Installation contrary to instructions invalidates warranty.
- ③ Screen should be accessible for complete removal should fabric become damaged or should other service be required.
- ④ Screen should be installed level (using a carpenter's level).
- ⑤ Nothing should be fastened to screen dowel or viewing surface.
- ⑥ Operating switch(es) packed separately in screen carton. Do not discard with packing material.
- ⑦ Screen operates on 110-120V, 60 Hz., 1.1 amp current draw.

NOTE: Screen has been thoroughly inspected and tested at factory and found to be operating properly prior to shipment.

These instructions are meant as a guide only. They do not imply any responsibility on the part of Draper, Inc. for improper installation or faulty workmanship at the jobsite.

Wall/Ceiling Flush Mounting

- ① Attach Mounting Brackets to wall or ceiling (see Fig. 1). The installer should furnish screws, toggle bolts, molly bolts, nylon or lead anchors as required by the mounting surface. Installer also needs to ensure the mounting surface is reinforced sufficiently to support the screen. **Brackets must be level with each other.**

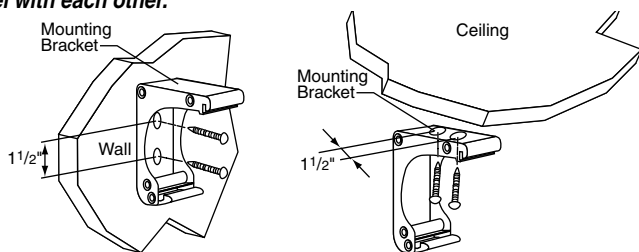

Figure 1

- ② Attach the screen by snapping the extrusions on the back of the case onto the brackets. With the lower edge of the screen case tilted away from the wall, engage the rib on top of the case with the slot on each bracket. Slide the screen case along the brackets to adjust the screen location from left to right if necessary (see Fig. 2). Once the case is in position, pivot the case back toward the brackets until the lower edge of the case "snaps" into place with the spring-loaded latch (see Fig. 3).

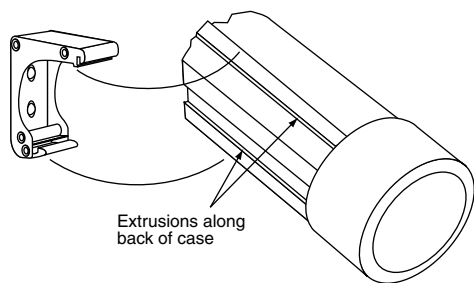

Figure 2

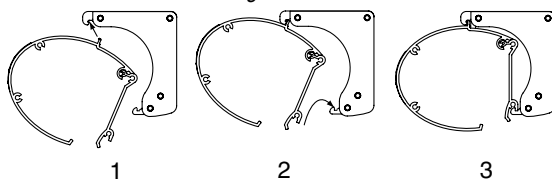

Figure 3

Electrical Connections

Screen operates on 110-120V AC, 1.1 amp current draw. Duty cycle: On

26 seconds/Off 3 minutes. Screen shipped with internal wiring complete. Junction box is located inside left endcap and cover plate is secured to endcap with one screw. Junction box contains red, black and white pigtail leads and green internal ground wire, per wiring diagram on reverse.

Screen is shipped with internal wiring complete and control switch(es) fully boxed. Wire connecting screen to switch(es) and switch(es) to power supply should be furnished by installer. Connections should be made in accordance with attached wiring diagram, and wiring should comply with National and local electrical codes. When connections are complete, test screen operation. The switch cover plate is not labeled "Up" and "Down." If screen operates in the opposite direction of the switch button (i.e. pressing switch up makes the screen go down), no re-wiring is necessary; simply flip the switch 180 degrees.

All operating switches should be "OFF" before power is connected.

Operation

Screen is equipped with a handheld remote or 3-position operating switch (see below). Three positions (up-off-down) permit operation to be stopped at any point. Factory adjusted limit switches automatically stop screen when fully down or fully up.

Wiring/Control Options:

Salara/Hardwire—Provided with 3-position wall switch for 110-120V AC. Controls for 110-120V AC hardwired Salara:

110-120V Single Station Control — 3-position up-off-down switch permits operation to be stopped at any point. Factory adjusted limit switches automatically stop screen when fully down or fully up.

110-120V Multiple Station Control—Switches are similar in appearance to 110V Single Station Control. Screen stops when switch is released and may be restarted in either direction. Factory adjusted limit switches stop screen automatically when fully down or fully up.

24V Control — Three-button up-stop-down switches stop at any point desired, operate in any sequence. Factory adjusted limit switches automatically stop screen when fully down or fully up.

Key Operated Switching — Two kinds of key-operated switches are optionally available with this unit.

- ① The key-operated power supply switch controls power to the screen and switches. When it is "off", the switches will not operate screen. Key may be removed from the switch in either "on" or "off" position.
- ② A three-position key switch permits the screen to be operated directly by key. In this case, the screen's operator must always have a key.

RS232/Ethernet—Serial communication and network communication optionally available with wall switches, RF or IR remote.

Salara/Hardwire with Built-in IR—Provided with handheld infrared remote transmitter.

Adjustments

Please Note: Screen limits are factory set for optimum performance of the screen. A procedure is outlined below for minor tweaks, but any adjustment of these limits may negatively affect the flatness of the screen surface and could also void the warranty. Please check with Draper prior to resetting screen limits.

⚠ CAUTION: Always be prepared to shut screen off manually when new adjustment is being tested. Screen may be severely damaged if viewing surface is allowed to run too far up or too far down.

⚠ CAUTION: Be sure all switches are in "off" position before adjusting limit switches.

Standard or IR Hardwired Salara

There are two holes in the left end cap (as seen from audience) for both limit switch adjustments and neither is labeled. The hole closest to the audience is the up limit and the hole furthest from the audience is the down limit

"Down" limit switch: Down stopping position can be adjusted by turning knob furthest from audience with a screw driver or hex wrench. Turning knob counterclockwise will allow viewing surface to run farther down. Turning it clockwise will reduce the amount of exposed viewing surface.

"Up" limit switch: You should never have to adjust this limit! If you do, however, the Up stopping position can be adjusted by turning knob closest to audience with a screw driver or hex wrench through the small grommet. Turning knob counterclockwise will allow surface to run farther into the screen case. Turning it clockwise will allow viewing surface to stop farther out of the screen case.

Dimensional drawings on page 2

If you encounter any difficulty installing or servicing your Salara, call your dealer or Draper, Inc., Spiceland, Indiana, (765) 987-7999 or fax (765) 987-7142.

DRAPER

411 S. Pearl St., Spiceland, IN 47385 USA ■ 765-987-7999

www.draperinc.com ■ fax 765-987-7142

Copyright ©2015 Draper Inc. Form Salara-HW_Inst15 Printed in U.S.A.

Caution: Do not remove the roller assembly from the case unless necessary for repairs. If the roller assembly is removed, be sure motor is fully re-seated in the bracket, and re-secure it carefully with the motor retaining spring (see diagram at right).

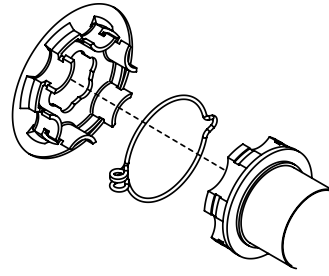

Dimensions

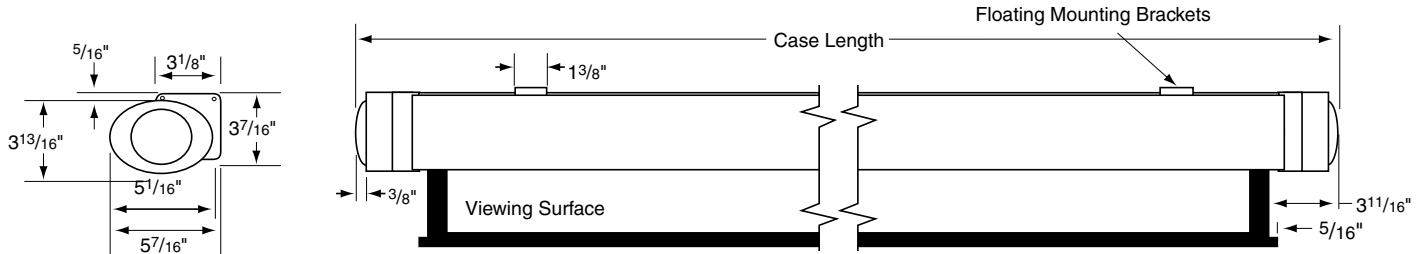

Wiring Diagrams

Standard 110-120V Salara/Hardwire

Please Note: Do not wire motors in parallel.

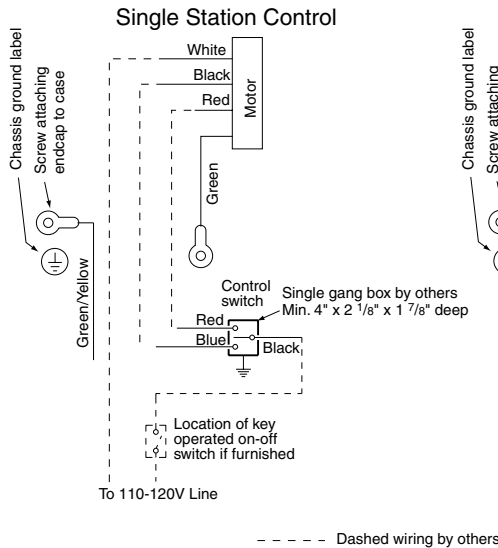

Multiple Station Control

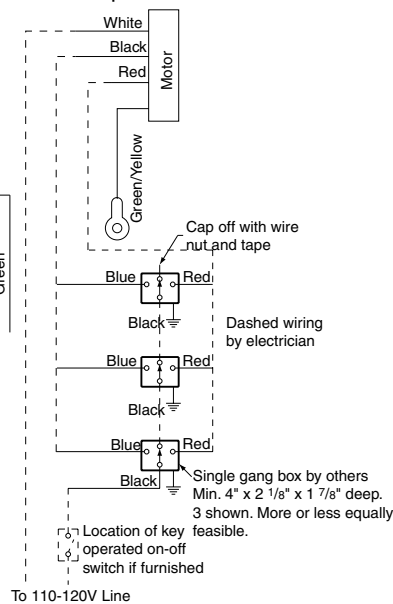

110-120V Salara/Hardwire with Built-in IR

Please Note: Do not wire motors in parallel.

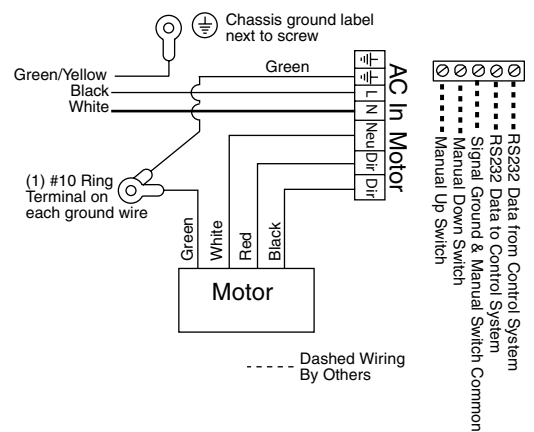

Low Voltage & Wireless Control

