

PWB-320XL Box Installation

1. ASSEMBLE PWB-320-AC3 AND MAKE ELECTRICAL CONNECTIONS AS REQUIRED IN ACCORDANCE WITH ALL APPLICABLE ELECTRICAL CODES. INSTALL AS SHOWN. (6 AVAILABLE POSITIONS FOR PWB-320XL)

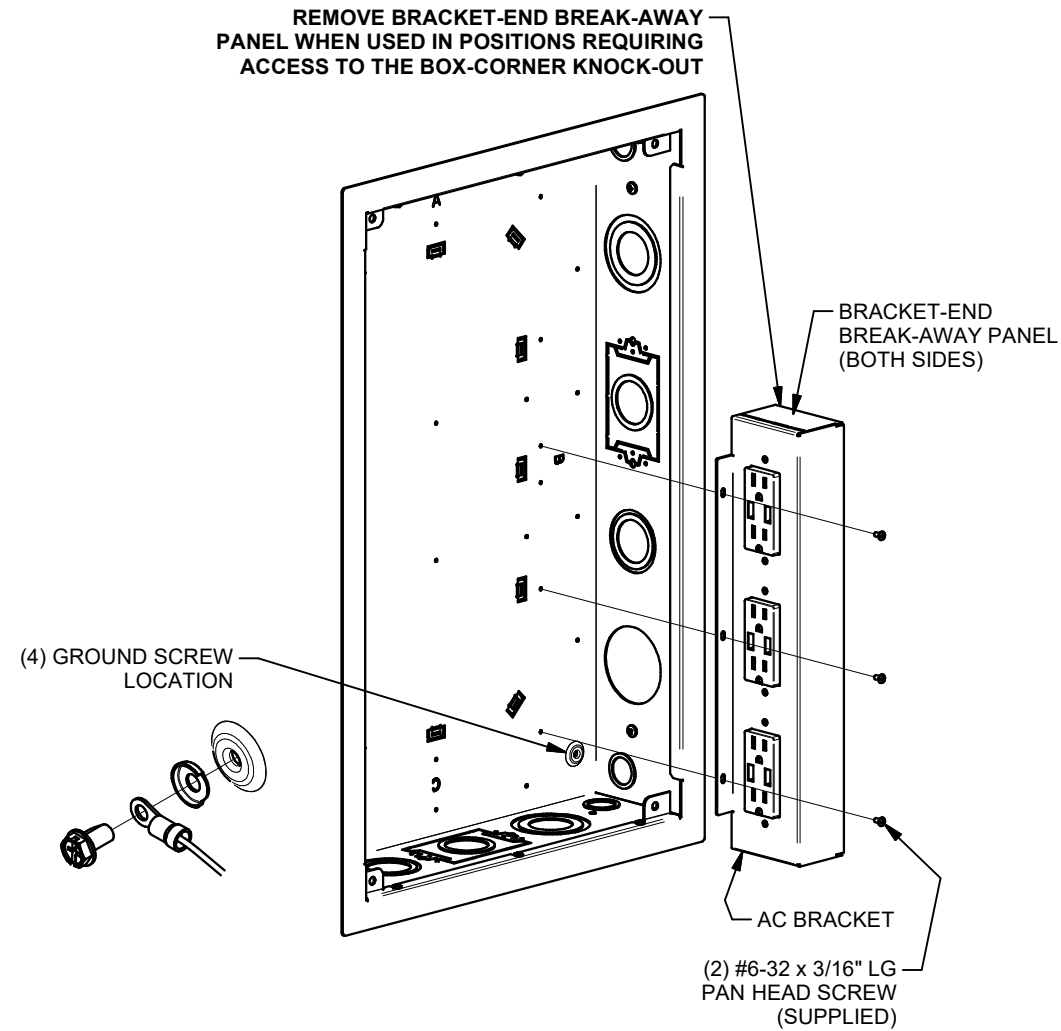

POSSIBLE PWB-320-AC3 LOCATIONS

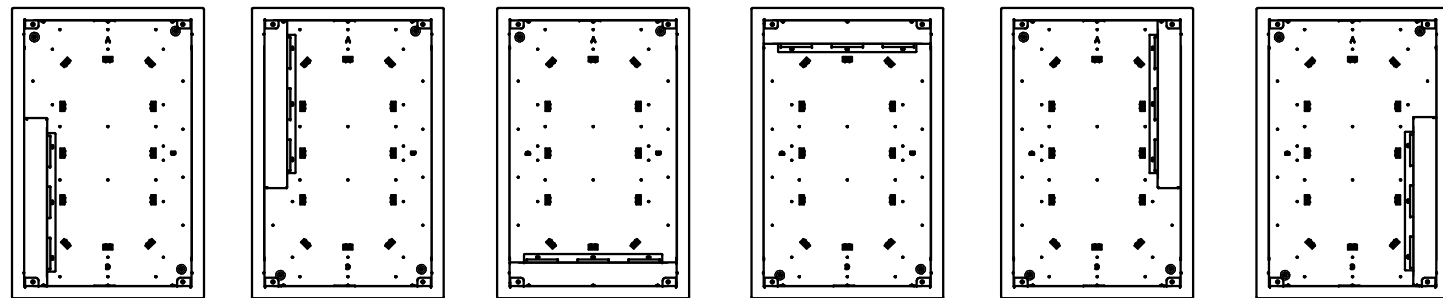

PWB-320/323 Box Installation

1. AC BRACKET CAN BE MOUNTED HORIZONTALLY OR VERTICALLY.

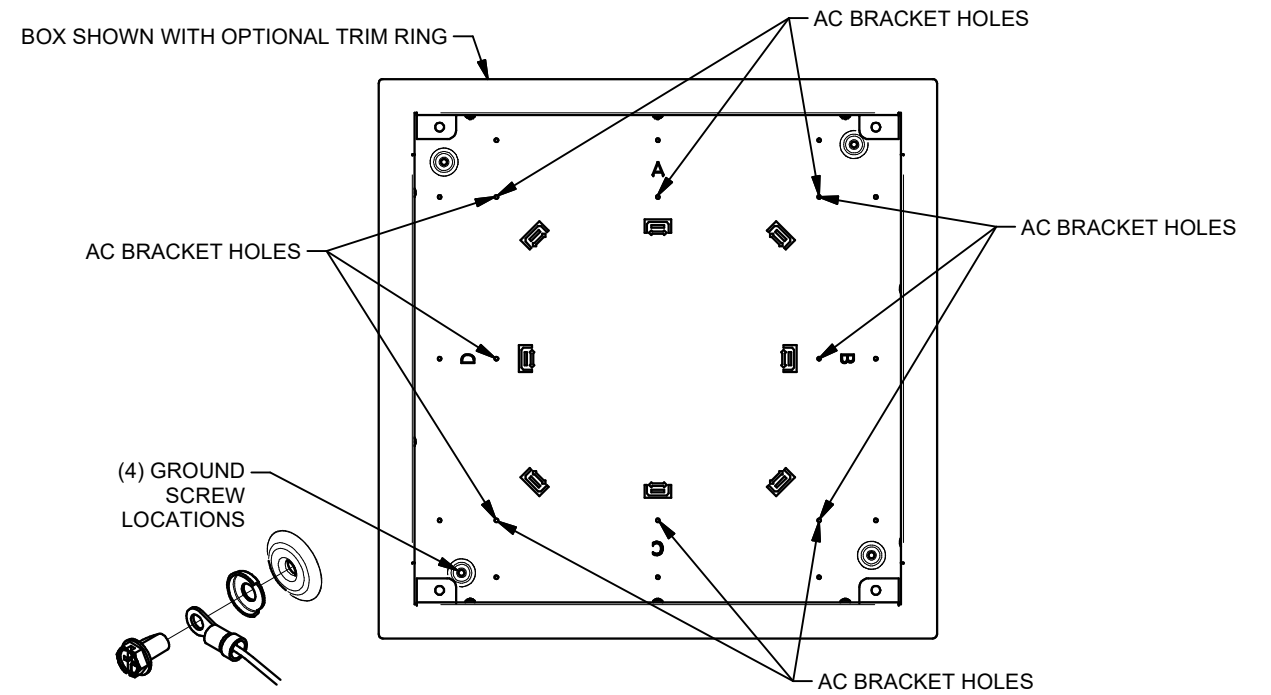

- 2a. ASSEMBLE PWB-320-AC2 AND MAKE ELECTRICAL CONNECTIONS AS REQUIRED IN ACCORDANCE WITH ALL APPLICABLE ELECTRICAL CODES. INSTALL AS SHOWN. (8 AVAILABLE POSITIONS FOR PWB-320-AC2) (4 AVAILABLE POSITIONS FOR PWB-323-AC2)

- 2b. ASSEMBLE PWB-323-AC3 AND MAKE ELECTRICAL CONNECTIONS AS REQUIRED IN ACCORDANCE WITH ALL APPLICABLE ELECTRICAL CODES. INSTALL AC BRACKET AS SHOWN IN ANY OF THE 4 AVAILABLE POSITIONS.

REMOVE BRACKET-END BREAK-AWAY PANEL WHEN USED IN POSITIONS REQUIRING ACCESS TO THE BOX-CORNER KNOCK-OUT

REMOVE BRACKET-END BREAK-AWAY PANEL WHEN USED IN POSITIONS REQUIRING ACCESS TO THE BOX-CORNER KNOCK-OUT

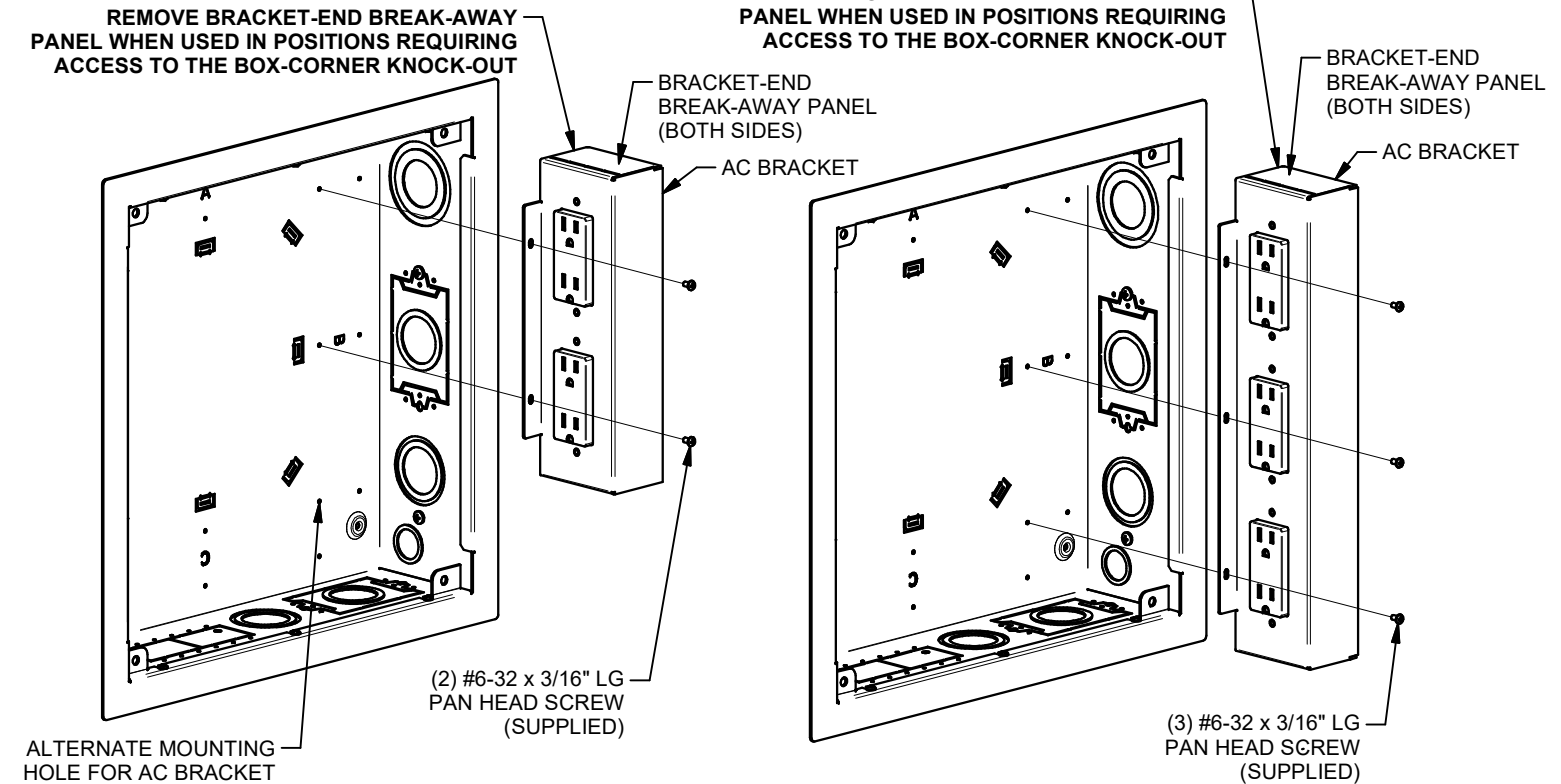

PWB-HVBX Box Installation

1. ASSEMBLE PWB-320-AC2 AND MAKE ELECTRICAL CONNECTIONS AS REQUIRED IN ACCORDANCE WITH ALL APPLICABLE ELECTRICAL CODES. INSTALL AS SHOWN. (2 AVAILABLE POSITIONS FOR PWB-HVBX)

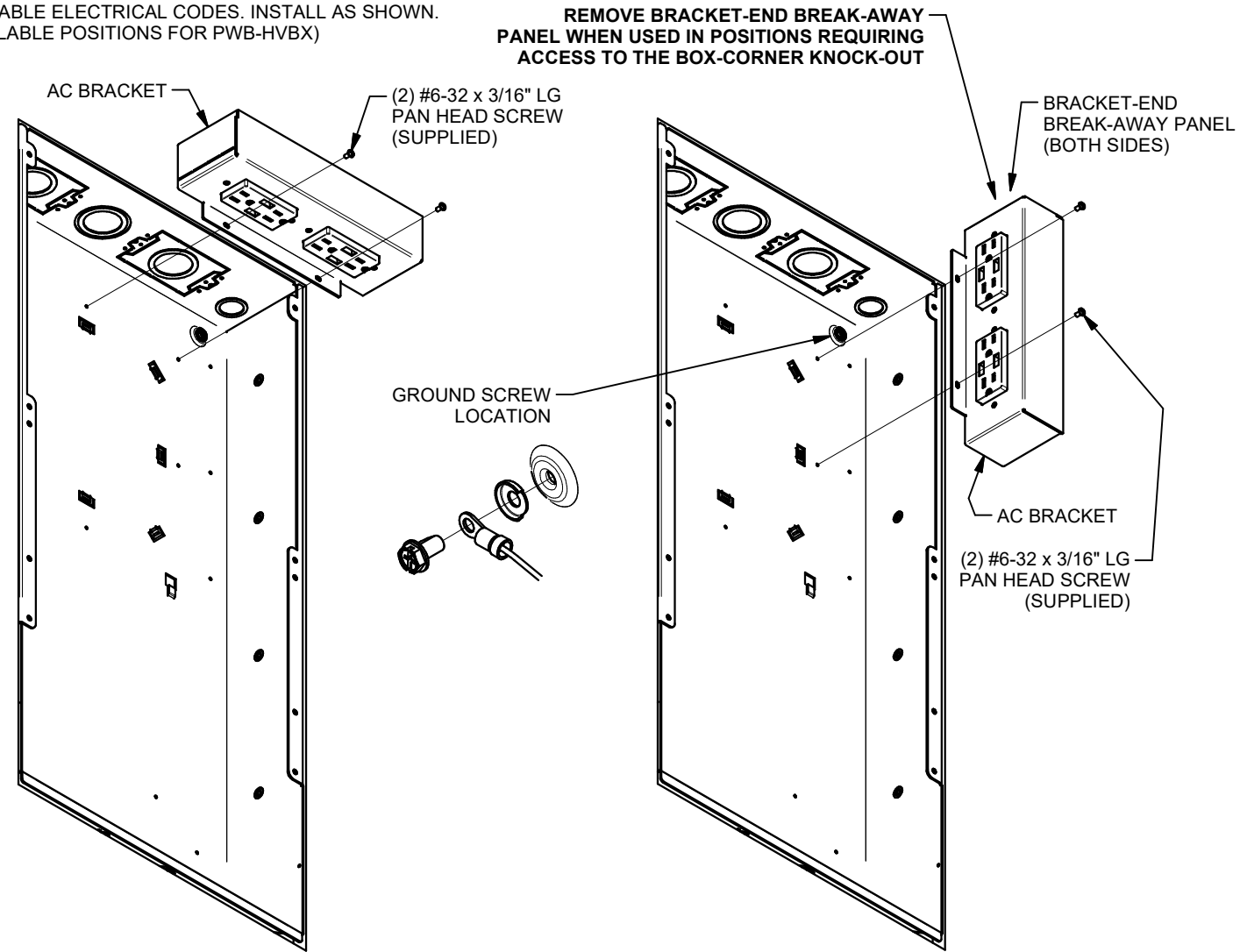

2. SHELF MOUNTING BRACKETS (SOLD SEPARATELY) WILL HAVE TO BE SHORTENED IF INSTALLED AS SHOWN.

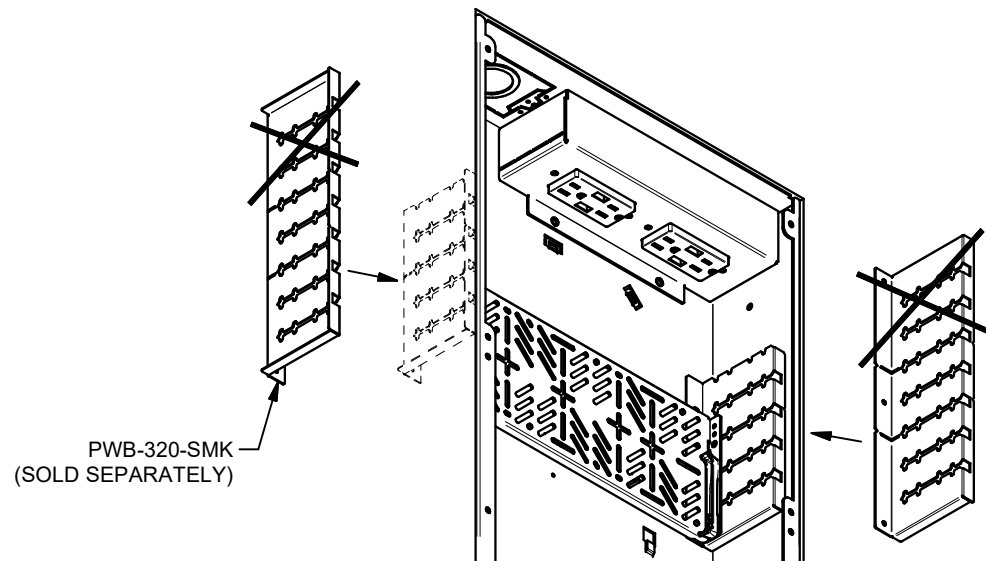

PWB-320XL Box Installation

1. ASSEMBLE PWB-320-AC2 AND MAKE ELECTRICAL CONNECTIONS AS REQUIRED IN ACCORDANCE WITH ALL APPLICABLE ELECTRICAL CODES. INSTALL AS SHOWN. (8 AVAILABLE POSITIONS FOR PWB-320XL)

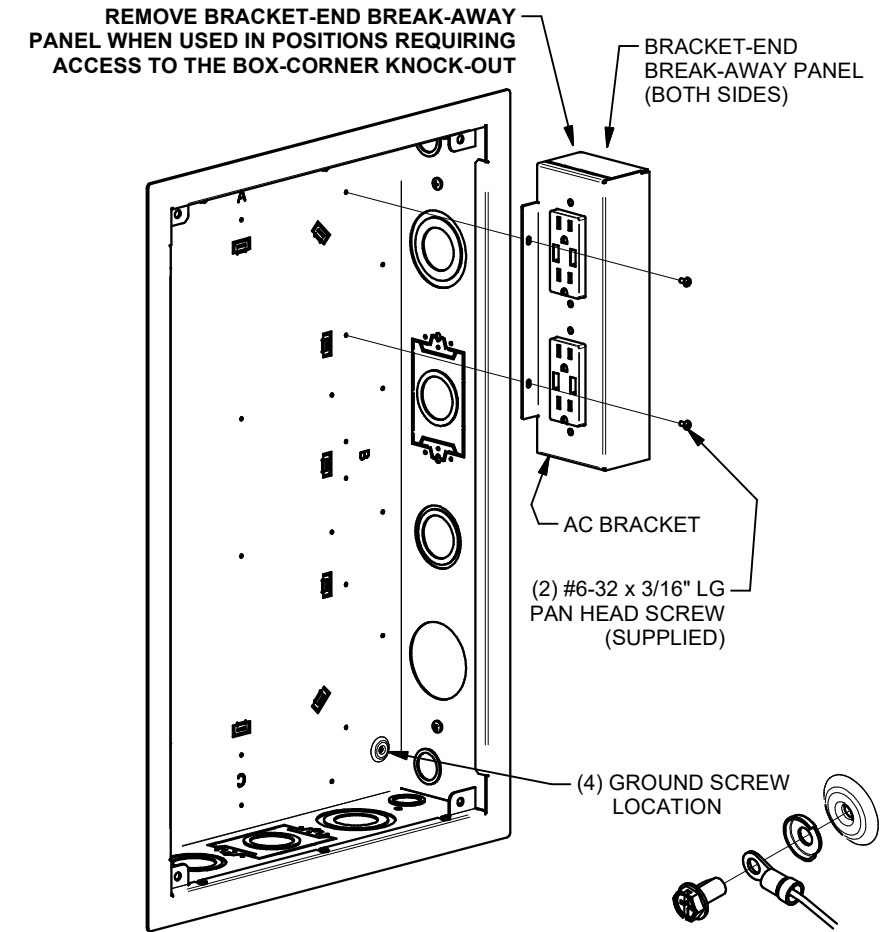

POSSIBLE PWB-320-AC2 LOCATIONS

