

ECM

UHF



USER'S MANUAL

ANY SPOT[®]

WIRELESS MICROPHONE SYSTEM

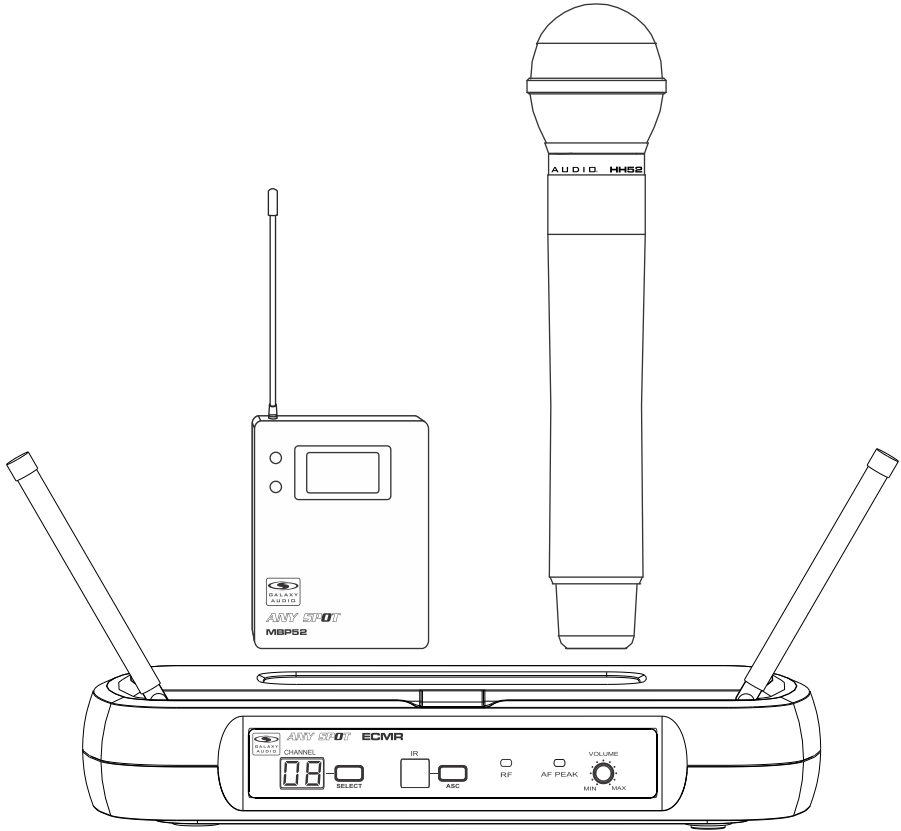

MAKERS OF THE ORIGINAL
HOT SPOT PERSONAL MONITOR

System Components

All ECM systems include the following components:

ECMR Receiver
 One 1/4" Audio Cable
 Power Adapter
 User Manual



ECMR

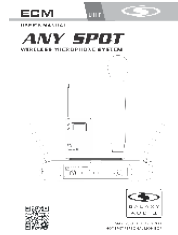

Manual

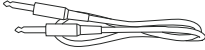

**1/4" to 1/4"
 Audio Cable**

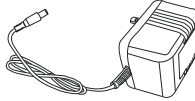

**PS-13.5-.35.5
 Power
 Adaptor**

Handheld Microphone Systems:
 HH52 Handheld Transmitter



HH52

Lavalier/Headset/Guitar Systems:
 MBP52 Body Pack Transmitter
 Microphone (choice of Lavalier,
 Headset, or Guitar Cable)

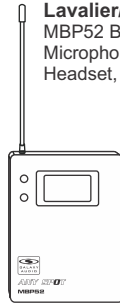

MBP52



LV-U3BK



HS-U3BK



AS-GTRVE

Wireless Guitar Bud System:
 Guitar Bud (Multiple Frequencies Available)



GBD

Wireless Headset Transmitter System:
 Wireless (Headset Transmitter)

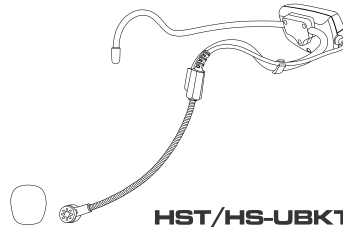

HST/HS-UBKT

**Replacement parts can be purchased
 at www.galaxyaudio.com**

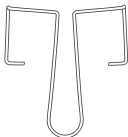

AS-CLIP911R
 Belt Clip
 for MBP52



BATTCLR11005264
 Battery Cover
 for MBP52



WS-GR52
 Mesh Grill Cover
 for HH52

Functions of the ECMR Receiver

Front Panel

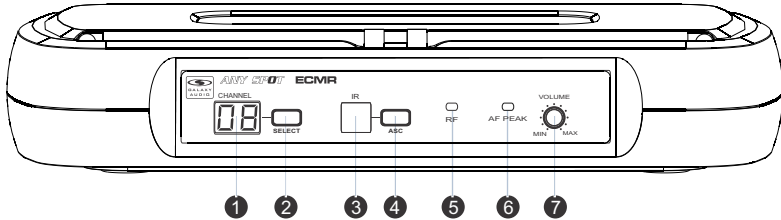

- 1 Channel Display.
Displays selected Channel.
- 2 Channel select button
- 3 IR Window.
Unit sends Infrared Signal to the Transmitter through this Window for Frequency Synchronization.
- 4 ASC Synchronizing Signal Transmit Button.
Press this Button to establish Infrared connection between the Receiver and Transmitter.
- 5 RF Signal LED
- 6 Audio LED. Indicates a peak Audio Signal.
- 7 Audio Output Level Control.
Left turn for Output Level Decrease, right turn for Output Level Increase.

Rear Panel

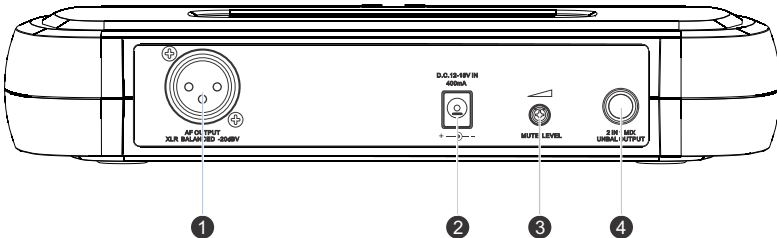

- 1 AF Audio Output.
- 2 Power Adapter Jack.
- 3 AF Output fine adjustment of Mute Threshold Level.
This is factory set and usually does not need to be adjusted.
If interference signals are present, this Threshold Value can be Increased by turning the knob Clockwise until RF Signal LED goes out.
- 4 1/4" Audio Output.

HH52/HH52SC Handheld Transmitter

Functions:

- ① Microphone Head.
- ② Gain (Sensitivity) Control.
Turn Left to Decrease Sensitivity.
Turn Right to Increase Sensitivity.
- ③ RF Power Level Switch.
H for High Level RF Power.
L for Low Level RF Power.
- ④ IR Window.
Receives Infrared signal to synchronize frequencies
between Receiver and Transmitter.
- ⑤ Battery Tray.
- ⑥ Power/ASC/Low Battery Indicator.
Green: Power On.
Flashing Green: IR Transmission in progress.
Red: Batteries Low.
- ⑦ Power On/Off Switch.

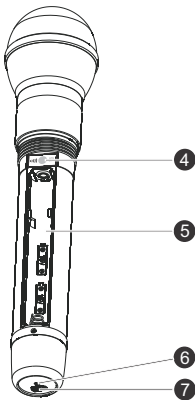
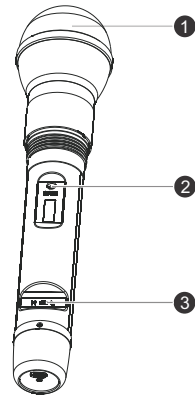

Changing Batteries:

Unscrew cover to access the Battery Tray. Observe correct polarity markings when installing Batteries. Expected life for two alkaline batteries is about 8 hours.

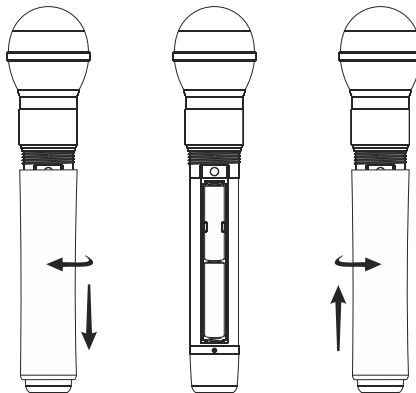

MBP52 Bodypack Transmitter

Functions:

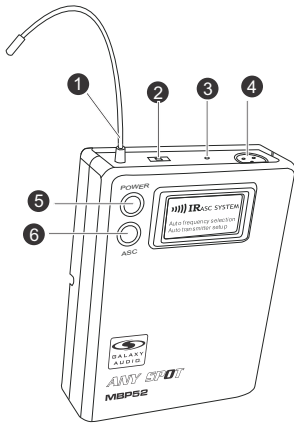

- ① Antenna.
- ② Input Gain Switch.
There are three Gain settings. Select the setting most suitable to your application.
Mic.: Microphone Level.
0: Guitar Level.
-10dB: Line Level.
- ③ Power/Low Battery/IR Transmission LED.
Green: Power On, Batteries OK.
Flashing Red: Low Batteries.
Flashing Green: IR transmission in Progress.

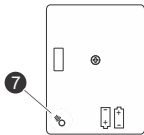

- ④ 3-pin Input Jack.
- ⑤ Power Button.
Press and Hold to switch Power On/Off.
- ⑥ ASC Automatic Frequency Synchronization.
Press this button to establish Infrared connection between the Transmitter and Receiver.
- ⑦ IR Window.
This window receives the Infrared signal during ASC.

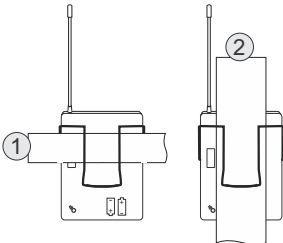

How to Wear the MBP52 Transmitter:

Slide the transmitter clip onto the belt ①, or run a guitar strap through the transmitter clip ②, as shown in the diagram at left.

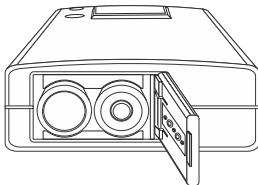

Battery Replacement:

Slide open the Battery Door as shown. Install Batteries while observing correct polarity markings.

The life expectancy of two alkaline batteries is about 8 hours.





ECMR Receiver Setup:

Channel Selection

Press channel Selector button to select desired Channel. When switching Channels, wait for the Channel number display to stop blinking before using the ASC function. For best results when operating multiple systems, set every channel to achieve the maximum distance between channels.

Receiver Volume Control:

Turn Left for Output Level decrease, turn Right for Output Level increase.

Mute Level Threshold Adjustment:

The Mute Level is factory set and normally needs no adjustment. However, you may turn clockwise if interference is present.

Automatic Transmitter Setup (ASC):

Remove the access cover on the Handheld Transmitter. Point the IR Window of the Handheld towards the IR Window on the Receiver and press the ASC button.

Start by pressing the ASC button on the MBP52 transmitter belt pack. The LED on top will flash green for 15 seconds. While it's flashing, point the IR window of the MBP52 belt pack towards the IR window on the Receiver, and press the ASC button on the ECMR receiver. If you have successfully synced them, the orange RF LED on the ECMR receiver will turn on indicating a signal from the transmitter.

Note: when establishing infrared connection between the receiver and the transmitter, the distance between them should not exceed 1.64ft (0.5m). When more than one system are used, only IR window of one transmitter should be pointed to the receiver for each infrared connection.

"Only one IR Window from each transmitter should be pointed to the receiver for each infrared connection."

ECM System

Available Channels: 16
Frequency Range: CODE D 584 - 607 MHz
 CODE L 655 - 679 MHz
 CODE N 518 - 542 MHz
Transmitter Output level: 10 dBm
Band: UHF

Operating Range Under Typical Conditions: 150' (50m)
 Note: actual range depends on RF signal absorption, reflection, and interference.

Audio Frequency Response: (+/-3dB) 60Hz~16KHz

Total Harmonic Distortion (+/-30KHz deviation, 1KHz tone): <1%

Dynamic Range: >90dB A-weighted

Operating Temperature Range:
 14°F to 122°F (-10° C to +50° C)

Note: battery characteristics may limit this range.

Bodypack Transmitter: MBP52

Audio Input Level: 0 dBV to +10dBV

Gain Adjustment Range: mic/0/-10

Input Impedance: 5KΩ

Dimensions: 3.3" x 2.6" x 1"
 (85mm H x 65mm W x 24mm D)

Weight: 3.0oz (85 g) (without batteries)

Power Requirements: 2 AA Batteries alkaline or rechargeable batteries

Battery Life: About 8 hours

Handheld Transmitter: HH52

Max Audio input level: 0dBV

Gain (Sensitivity): Control High/Low RF power switch.

Dimensions: 9.8" x 2.1" dia. (250mm x 53mm dia.)

Weight: 9.5oz (270 g) (without batteries)

Power Requirements: 2 "AA" size alkaline or rechargeable batteries

Battery Life: About 8 hours

Receiver: ECMR

Audio Output Level: (+/-30KHz deviation, 1KHz tone)
 XLR connector (into 600Ω load) -12dBV
 ¼" connector (into 3KΩ load) -18dBV

Output Impedance: XLR connector 200Ω
 ¼" connector 1KΩ

XLR output: Impedance balanced
 Pin1: Ground (cable shield)
 Pin2: Audio
 Pin3: No Audio

Sensitivity: -93dBm for 30dB

Image Rejection: >90dB

Dimensions: 1.75" x 9.25" x 121"
 (44.45mm H x 235mm W x 121mm D)

Weight: 0.85lbs (0.39kg)

Power Requirements: 13.5 V dc at 300mA, supplied by external power supply.

ECM Frequency Chart

ECM D CODE

1	584.400
2	587.500
3	589.575
4	591.050
5	593.425
6	595.200
7	598.450
8	599.650
9	601.275
10	603.775
11	605.500
12	606.750
13	586.025
14	590.525
15	594.150
16	602.450

ECM L CODE

1	655.200
2	656.675
3	658.500
4	660.050
5	661.500
6	662.900
7	664.425
8	666.500
9	667.800
10	669.225
11	670.800
12	672.275
13	673.725
14	675.075
15	676.500
16	678.600

ECM N CODE

1	518.625
2	519.900
3	520.525
4	521.950
5	523.700
6	524.575
7	526.075
8	531.200
9	531.950
10	534.025
11	535.250
12	537.200
13	538.200
14	539.650
15	540.750
16	541.475



MAKERS OF THE ORIGINAL
HOT SPOT PERSONAL MONITOR



www.galaxyaudio.com

THREE YEAR LIMITED WARRANTY

WARRANTY Information can be viewed online at
<https://www.galaxyaudio.com/support/warranty>



www.galaxyaudio.com/support/warranty

ECM USER'S MANUAL

Specifications in this manual are subject to change without notice.
For the most up to date manual and information
visit www.galaxyaudio.com.

1-800-369-7768 www.galaxyaudio.com

© Copyright Galaxy Audio 2017