

# PT-ELITE-PRO

## QUICKSTART GUIDE

Elite Universal Large Tablet, Surface Pro, & iPad Pro Teleprompter



### What's Included

- 1 x Glass Assembly
- 1 x Magnetic Hood
- 2 x 12-Inch Rods
- 1 x Baseplate Assembly
- 1 x Large Tablet Holder
- 1 x Large Tablet Holder Extension Mount & D-Ring



# ikan

[www.ikancorp.com](http://www.ikancorp.com)

[support@ikancorp.com](mailto:support@ikancorp.com)

713.272.8822

© 2016 ikan Corporation. All rights Reserved

# PT-ELITE-PRO

## What's Included

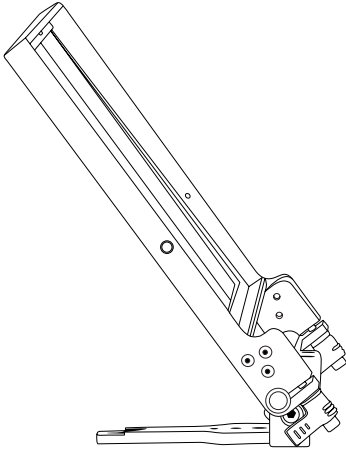

Glass Frame Assembly

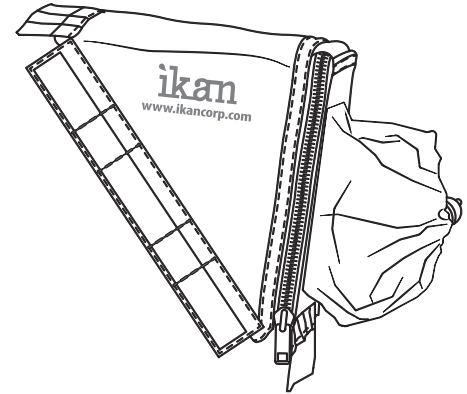

Magnetic Sunhood

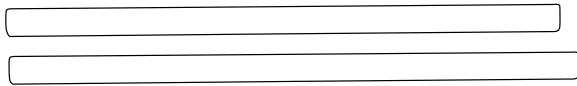

2 x 12-Inch Rods

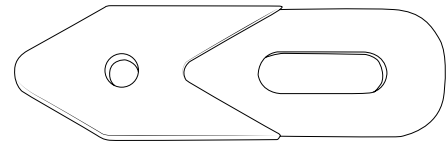

Large Tablet Holder Extension & D-Ring

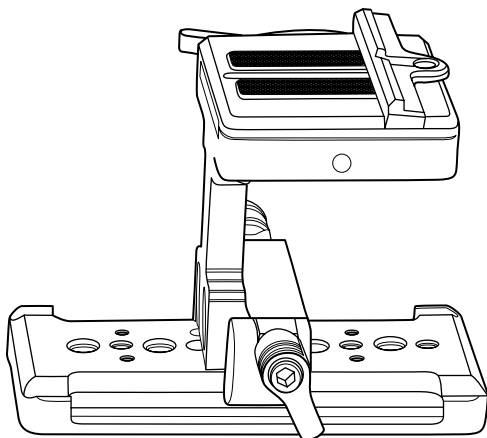

Baseplate Assembly

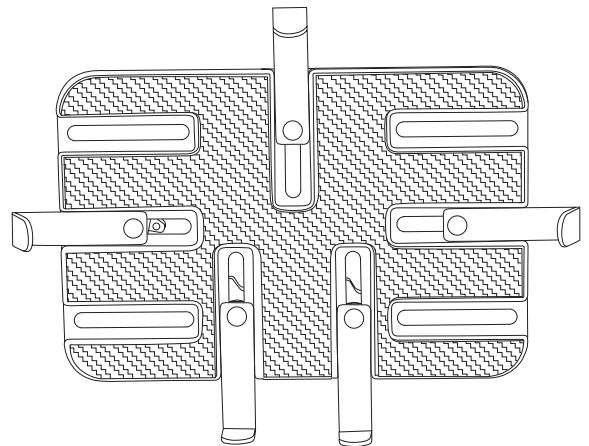

Tablet Holder

# PT-ELITE-PRO

## How to Assemble

1. Attach tablet mount to glass frame assembly. **Figures 1a, 1b, 1c.**

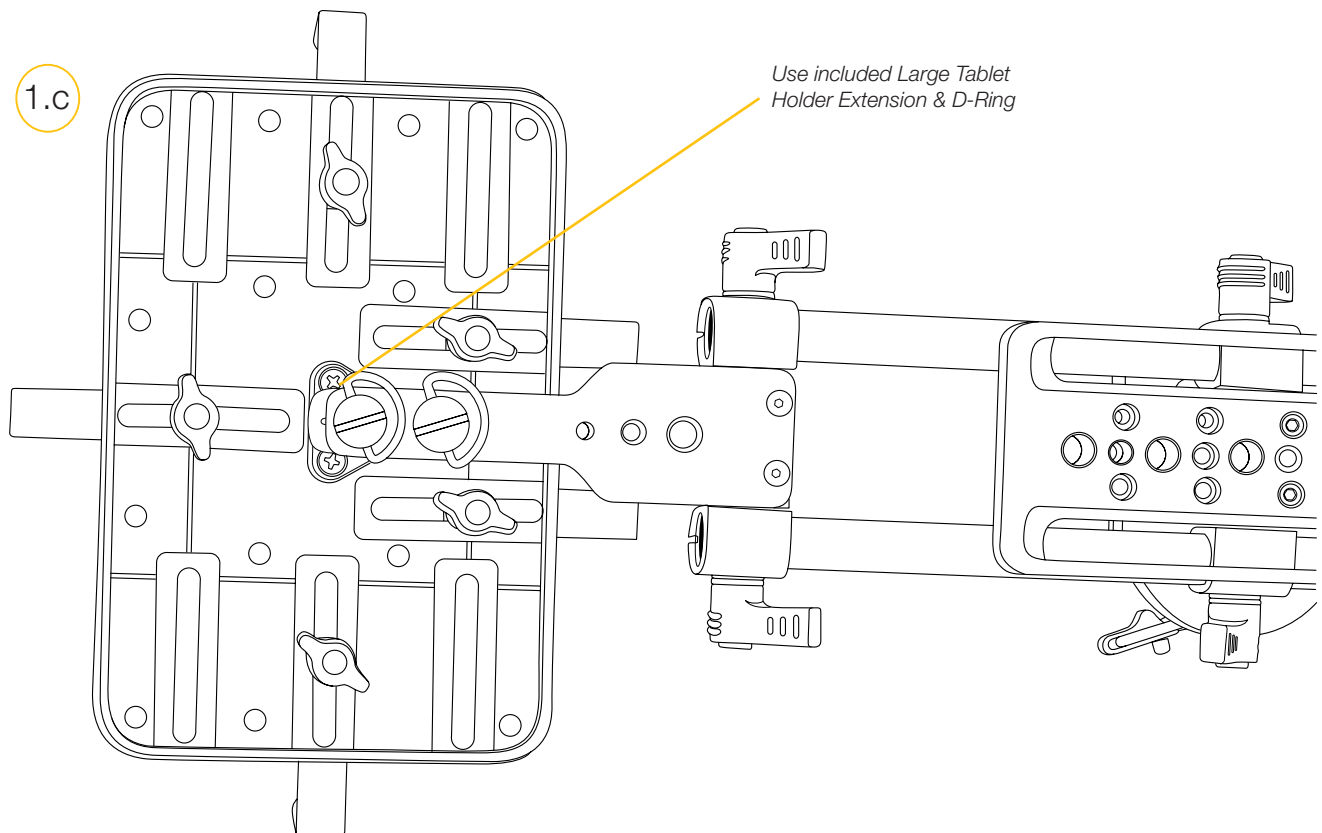
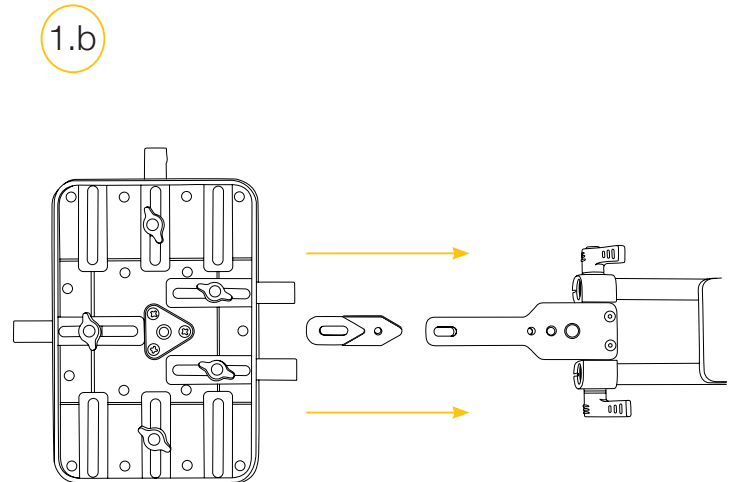
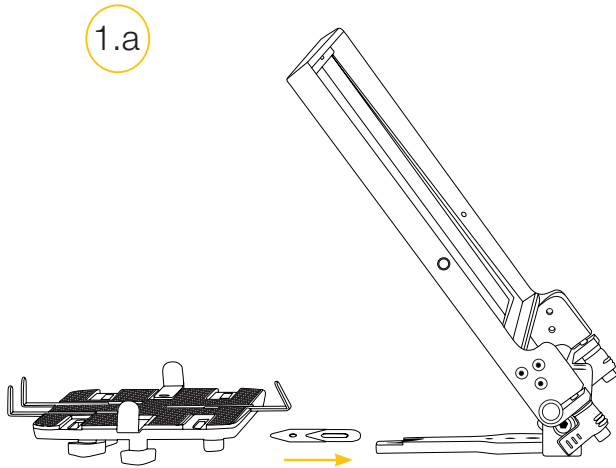

# PT-ELITE-PRO

2. Insert rods into rail mount on glass frame assembly.
3. Slide baseplate onto rods.
4. Adjust spacing for your camera.
5. Tighten & loosen thumb screws to adjust glass frame. *Ideal angle is 45 degrees.*

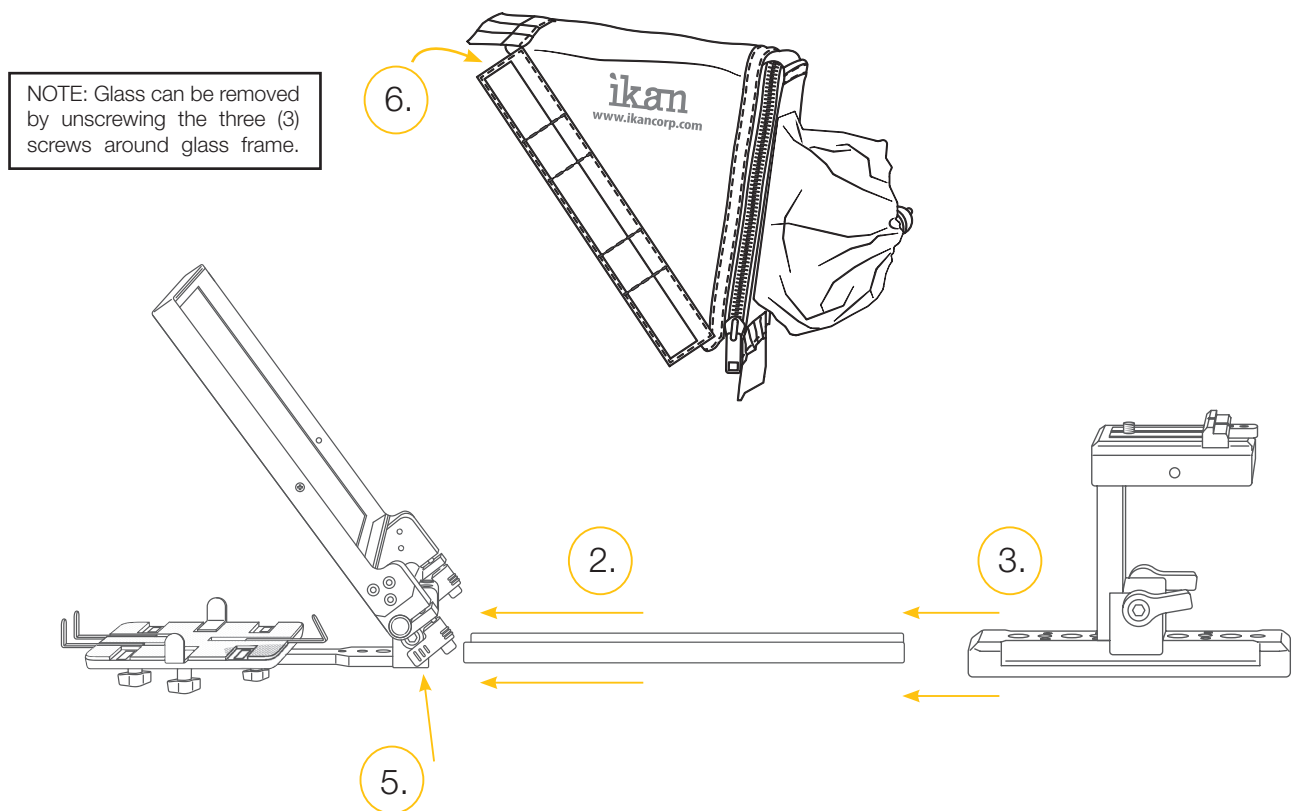

6. Attach magnetic hood to glass frame.
7. Remove quick release plate & attach your camera. Reattach.

## DO NOT THROW AWAY FOAM INSERT.

8. The PT-ELITE-PRO comes packaged in high quality custom-cut foam. It is sized perfectly to fit inside an SKB-i Series 1914-8 waterproof case.

## Software Options

**Windows:** Choose from PrompterPro from Ikan, or from multiple third party options in the Windows Store or on the Web.

**iOS:** Download Ikan Elite Prompter App from App Store

**Android:** Choose from multiple 3rd party options on Google Play Store

## Learn More

More dynamic information at official website: [www.ikancorp.com](http://www.ikancorp.com)

## Support

Contact email: [support@ikancorp.com](mailto:support@ikancorp.com)

### CONDITIONS OF WARRANTY SERVICE

- Free service for one year from the day of purchase if the problem is caused by manufacturing errors.
- The components and maintenance service fee will be charged if the warranty period is expired.

Free Service will not be Provided in the Following Situations:(\*Even if the product is still within the warranty period.)

- Damage caused by abuse or misuse, dismantling, or changes to the product not made by the company.
- Damage caused by natural disaster, abnormal voltage, and environmental factors, etc.