



KRAMER ELECTRONICS LTD.

USER MANUAL

MODEL:

SL-12
Master Room Controller

P/N: 2900-000552 Rev 7



SL-12 Quick Start Guide

This guide helps you install and use your product for the first time. For more detailed information, go to http://www.kramerelectronics.com/support/product_downloads.asp to download the latest manual or scan the QR code on the left.

Step 1: Check what's in the box

- The **SL-12** Master Room Controller
- 1 Quick start guide
- 1 Power supply 12V DC)
- 4 Rubber feet

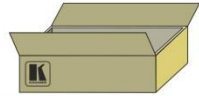

Save the original box and packaging materials in case you need to return your product for service.

Step 2: Install the SL-12

Mount the machine in a rack (using the RK-13 rack adapter) or place on a table.

Step 3: Connect the inputs and outputs

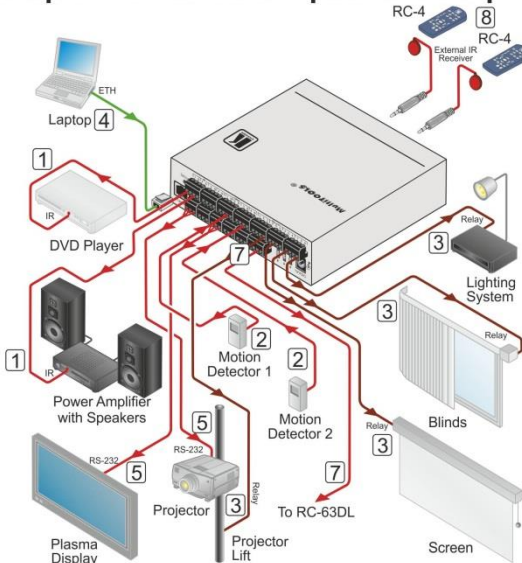

Always switch off the power on each device before connecting it to your **SL-12**.

- 1 Connect the IR outputs
- 2 Connect the GPI/O ports
- 3 Connect the relays
- 4 Connect the Ethernet
- 5 Connect the RS-232
- 6 Connect the RS-485 (not shown)
- 7 Connect the K-NET
- 8 Connect the external IR receivers

IR INPUT FUNCTIONALITY

You can use up to two optional RC-4 IR transmitters as auxiliary control panels and control the unit via two of the three IR INPUTS

Always use Kramer high-performance cables for connecting AV equipment to the **SL-12**.

Step 4: Connect the power

Connect the 12V DC power adapter to the **SL-12** and plug the adapter into the mains electricity.

Step 5: Operate the SL-12

Operate via the RC keypad, IR remote control, K-NET, or ETHERNET

Contents

1	Introduction	1
2	Getting Started	2
2.1	Achieving the Best Performance	2
2.2	Safety Instructions	3
2.3	Recycling Kramer Products	3
3	Overview	4
3.1	Defining the SL-12 Master Room Controller	5
4	Connecting the SL-12	7
4.1	Using the RC-4 IR transmitter	9
4.2	IR Input Functionality	9
4.3	Connecting the RS-232 Interface	10
4.4	Connecting the RS-485 Interface	11
4.5	Connecting the Ethernet Port	11
4.6	Connecting the K-NET Port	12
5	Operating the SL-12	12
6	Technical Specifications	13

Figures

Figure 1: SL-12 Master Room Controller	5
Figure 2: Connecting the SL-12 Master Room Controller	8
Figure 3: SL-12 IR Inputs	9
Figure 4: RS-232 Connection	11
Figure 5: RS-485 Connection	11
Figure 6: K-NET Pinout Connection	12

1 Introduction

Welcome to Kramer Electronics! Since 1981, Kramer Electronics has been providing a world of unique, creative, and affordable solutions to the vast range of problems that confront video, audio, presentation, and broadcasting professionals on a daily basis. In recent years, we have redesigned and upgraded most of our line, making the best even better!

Our 1,000-plus different models now appear in 11 groups that are clearly defined by function: GROUP 1: Distribution Amplifiers; GROUP 2: Switchers and Routers; GROUP 3: Control Systems; GROUP 4: Format/Standards Converters; GROUP 5: Range Extenders and Repeaters; GROUP 6: Specialty AV Products; GROUP 7: Scan Converters and Scalers; GROUP 8: Cables and Connectors; GROUP 9: Room Connectivity; GROUP 10: Accessories and Rack Adapters and GROUP 11: Sierra Products; GROUP 12: Digital Signage; GROUP 13: Audio; and GROUP 14: Collaboration.

Congratulations on purchasing your Kramer **SL-12** *Master Room Controller*, which is ideal for the following typical applications:

- Master room controller for room control systems
- Multimedia room control, such as classrooms, meeting rooms and auditoriums

2 Getting Started

We recommend that you:

- Unpack the equipment carefully and save the original box and packaging materials for possible future shipment
- Review the contents of this user manual



Go to www.kramerav.com/downloads/SL-12

to check for up-to-date user manuals, application programs, and to check if firmware upgrades are available (where appropriate).

2.1 Achieving the Best Performance

To achieve the best performance:

- Use only good quality connection cables (we recommend Kramer high-performance, high-resolution cables) to avoid interference, deterioration in signal quality due to poor matching, and elevated noise levels (often associated with low quality cables)
- Do not secure the cables in tight bundles or roll the slack into tight coils
- Avoid interference from neighboring electrical appliances that may adversely influence signal quality
- Position your Kramer **SL-12** away from moisture, excessive sunlight and dust



This equipment is to be used only inside a building. It may only be connected to other equipment that is installed inside a building.

2.2 Safety Instructions



Caution: There are no operator serviceable parts inside the unit

Warning: Use only the Kramer Electronics input power wall adapter that is provided with the unit

Warning: Disconnect the power and unplug the unit from the wall before installing

2.3 Recycling Kramer Products

The Waste Electrical and Electronic Equipment (WEEE) Directive 2002/96/EC aims to reduce the amount of WEEE sent for disposal to landfill or incineration by requiring it to be collected and recycled. To comply with the WEEE Directive, Kramer Electronics has made arrangements with the European Advanced Recycling Network (EARN) and will cover any costs of treatment, recycling and recovery of waste Kramer Electronics branded equipment on arrival at the EARN facility. For details of Kramer's recycling arrangements in your particular country go to our recycling pages at www.kramerav.com/support/recycling/.

3 Overview

The **SL-12** is a highly versatile controller that acts as an all-in-one control processor for control of AV equipment—especially projectors and associated equipment—in any room (such as classrooms, boardrooms, or auditoriums). It streamlines operations and simplifies control by integrating audio, video, and computer-video sources into a centralized system.

The **SL-12** features:

- An Ethernet port for controlling several AV products over ETH
- 4 general purpose I/O ports that can be configured as analog inputs, digital inputs, or digital outputs for interfacing with a variety of devices such as sensors, switches, LEDs, and relays
- 4 bidirectional RS-232 ports that control AV equipment such as projectors, LCD and PDP displays, power amplifiers, switchers and scalars
- 8 relay contact closure ports that control other room items related to the AV system such as raising and lowering drapes, the screen or the projector
- IR control on three inputs (one built-in receiver and two IR inputs on 3.5mm mini jacks) and four outputs (terminal blocks)
- IR Learning that learns commands from any IR remote
- 1 RS-485 serial port
- Compatibility with Kramer Site-CTRL software for network remote control and management over the Ethernet port
- A K-NET™ control channel that connects compatible user interfaces and supplies power and control data over a single cable
- A USB port for uploading a configuration file
- Status LEDs for all functions
- Flexible control via Ethernet, K-NET™, RS-485, IR receiver and external IR commands

3.1 Defining the SL-12 Master Room Controller

This section defines the **SL-12**.

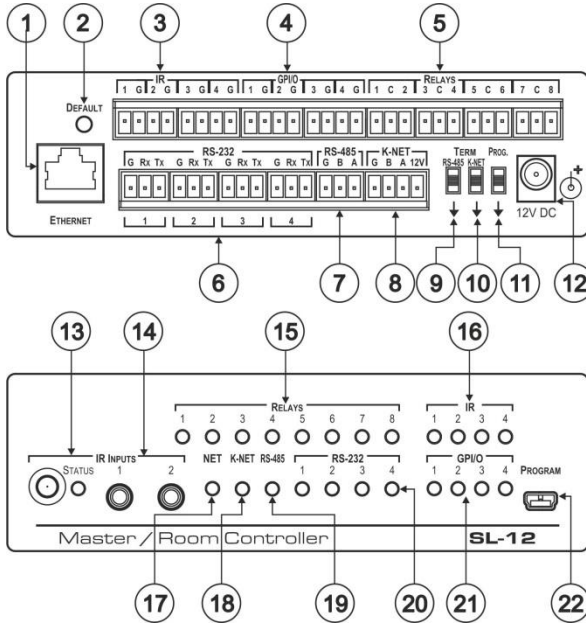

Figure 1: SL-12 Master Room Controller

#	Feature	Function
1	ETHERNET RJ-45 Connector	Connects to the PC or other serial controller through computer networking LAN to control several AV products over Ethernet
2	DEFAULT Recessed Pushbutton	Press to reset to factory default definitions: IP number – 192.168.1.39, Mask – 255.255.0.0, Gateway – 0.0.0.0 First disconnect the power supply and then connect it again while pressing the DEFAULT button. The unit powers up and loads its memory with the factory default definitions and erases all stored presets
3	IR Output Terminal Blocks	Connect to IR emitter cables (from 1 to 4)
4	GPI/O Terminal Blocks	Connect to various analog and digital sensors (from 1 to 4)
5	RELAYS Terminal Blocks	Connect to low-voltage relay-driven devices (from 1 to 8)
6	RS-232 Terminal Blocks	Connect to the RS-232 devices (from 1 to 4)
7	RS-485 Terminal Block	Pins B (-) and A (+) are for RS-485; Pin G may be connected to the shield (if required)

#	Feature	Function
8	<i>K-NET</i> Connector	PIN GND is for the Ground connection; PIN B (-) and PIN A (+) are for RS-485, and PIN +12V is for powering other units Note that the SL-12 cannot receive power via the K-NET connector, but can power other units (but not another SL-12)
9	<i>RS-485 TERM</i> Switch	Slides down for RS-485 termination, slides up for not terminated
10	<i>K-NET TERM</i> Switch	Slides down for K-NET termination, slides up for not terminated
11	<i>PROG.</i> Switch	For service use only
12	<i>12V DC</i>	12V DC connector for powering the unit
13	<i>IR INPUT</i> Built-in receiver and STATUS LED	Accepts IR remote commands (see Section 4.2)
14	<i>IR INPUT</i> 3.5mm Mini Jack	Connect to an external IR receiver (1 and 2)
15	<i>RELAYS</i> LEDs	Illuminate when an relay is active (1 to 8)
16	<i>IR</i> LEDs	Illuminate when an IR port is active
17	<i>NET LED</i>	Illuminates while transmitting over Ethernet
18	<i>K-NET</i> LED	Illuminates when the K-NET is active (red – transmit, green – receive, during normal activity flashes red)
19	<i>RS-485</i> LED	Illuminates while transmitting/receiving on an RS-485 port
20	<i>RS-232 (Tx/Rx)</i> LEDs	Illuminate while transmitting/receiving on an RS-232 port (1 to 4)
21	<i>GPI/O</i> LEDs	Illuminate while transmitting/receiving on a general purpose I/O port (1 to 4)
22	<i>PROGRAM</i> USB Connector	Connect to a computer for unit configuration and firmware upgrading

4 Connecting the SL-12



Always switch off the power to each device before connecting it to your **SL-12**. After connecting your **SL-12**, connect its power and then switch on the power to each device.

To connect the **SL-12** as illustrated in the example in [Figure 2](#):

1. Connect the RELAY terminal block connectors as follows:
 - Connect RELAY 1 and 2 to the projector lift
 - Connect RELAY 3 and 4 to the screen
 - Connect RELAY 5 and 6 to the blinds
 - Connect RELAY 7 and 8 to the lighting system
2. Connect the GPI/O ports as follows:
 - Connect GPI/O 2 to motion detector 1
 - Connect GPI/O 4 to motion detector 2
3. Connect the IR outputs as follows:
 - Connect an IR emitter to IR OUTPUT 1 and attach the emitter to the DVD player
P/N: C-A35M/IRE; two IR Emitter extension cables are also available: a 15 meter cable and a 20 meter cable.
 - Connect an IR emitter to IR OUTPUT 2 and attach the emitter to the power amplifier
4. Connect one or two IR INPUTS as follows (see [Section 4.2](#)):
 - Connect IR INPUT 1 to an external IR receiver
P/N: C- A35M/IRR two extension cables are also available: a 15 meter cable and a 20 meter cable.
 - Connect IR INPUT 2 to an external IR receiver

5. Connect the RS-232 ports as follows:
 - Connect RS-232 port 1 to the projector
 - Connect RS-232 port 3 to the plasma display
6. Connect the RS-485 to several Kramer matrices, for example (not shown in [Figure 2](#)).
7. Connect the Ethernet port to a network.
8. Connect the K-NET port to any RC device with K-NET.

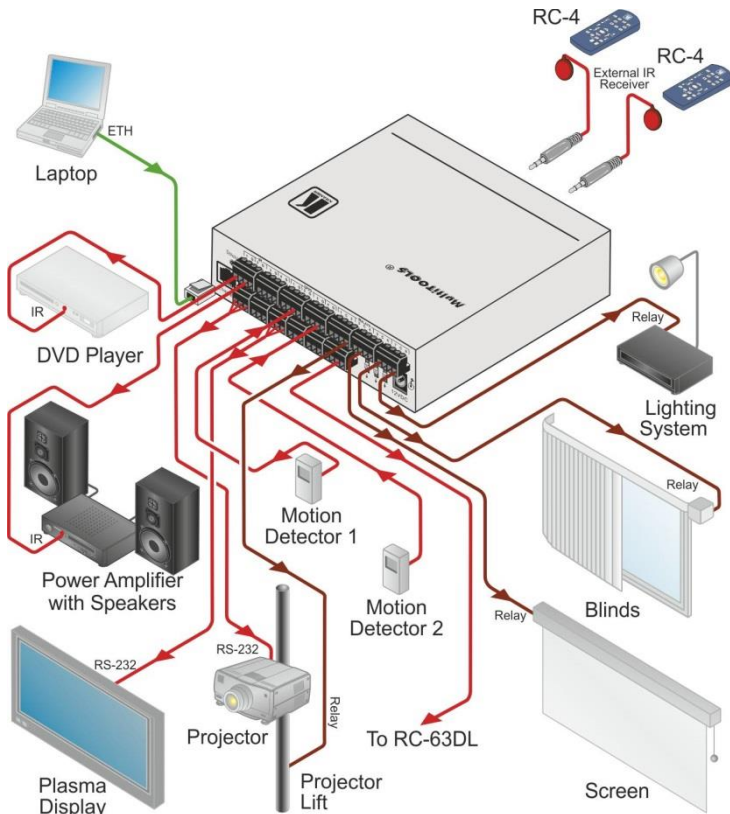

Figure 2: Connecting the SL-12 Master Room Controller

4.1 Using the RC-4 IR transmitter

You can use up to two optional **RC-4** IR transmitters as auxiliary control panels and initiate configured control triggers—refer to the **K-Config** guide—via the built in IR receiver on the front panel, and/or via the optional external IR receiver (C- A35M/IRR) that exists in several cable lengths.

4.2 IR Input Functionality

The **SL-12** front panel includes one built-in receiver and two IR inputs on 3.5mm jacks (shown in [Figure 3](#)) for control via the **RC-4**.

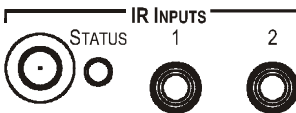
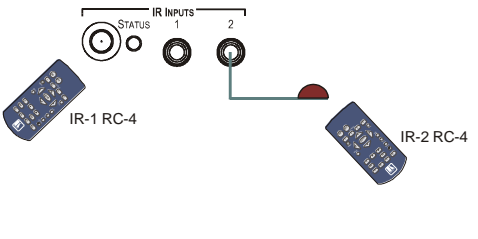
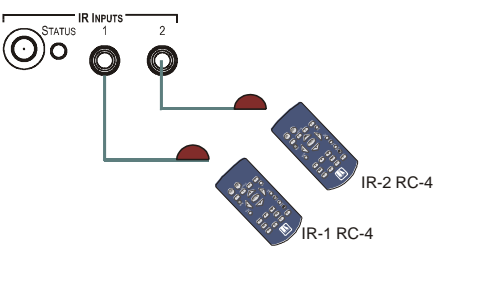

Figure 3: SL-12 IR Inputs

These three IR inputs can be set up differently, as shown in the following table:

Status	Operation in K-Config
<p>None of the external IR receivers are connected:</p> <p>IR-1 RC-4</p>	<p>RC-4 controls the unit through the built-in receiver</p> <ul style="list-style-type: none"> Define IR-1 – RC-4 as the auxiliary device and set the triggers
<p>An external IR receiver is connected to IR Input 1:</p> <p>IR-2 RC-4</p> <p>IR-1 RC-4</p>	<p>One RC-4 controls the unit through the built-in receiver and a second RC-4 unit controls the unit through the IR Input 1 external IR receiver:</p> <ul style="list-style-type: none"> Define IR-2 – RC-4 as the auxiliary device for the built-in receiver and set the triggers Define IR-1 – RC-4 as the auxiliary device for the external IR receiver connected to IR INPUT 1 and set the triggers

Status	Operation in K-Config
<p>An external IR receiver is connected to IR Input 2:</p> 	<p>One RC-4 controls the unit through the built-in receiver and a second RC-4 unit controls the unit through the IR Input 2 external IR receiver:</p> <ul style="list-style-type: none"> • Define IR-1 – RC-4 as the auxiliary device for the built-in receiver and set the triggers • Define IR-2 – RC-4 as the auxiliary device for the external IR receiver connected to IR INPUT 2 and set the triggers
<p>Two external IR receivers are connected to IR Input 1 and IR input 2, respectively:</p> 	<p>One RC-4 controls the unit through the IR Input 1 external IR receiver and a second RC-4 unit controls the unit through the IR Input 2 external IR receiver:</p> <ul style="list-style-type: none"> • Define IR-1 – RC-4 as the auxiliary device for the external IR receiver connected to IR INPUT 1 and set the triggers • Define IR-2 – RC-4 as the auxiliary device for the external IR receiver connected to IR INPUT 2 and set the triggers <p>The built-in IR receiver is disabled</p>



Note: when using two IR receivers, take care to place them in separate locations to prevent one IR receiver accepting transmissions that are sent to the other IR receiver.

4.3 Connecting the RS-232 Interface

To connect an AV device to the **SL-12** using the RS-232 port, connect the RS-232 9-pin D-sub port on your device to the RS-232 terminal block on the rear panel of the **SL-12** as shown in [Figure 4](#):

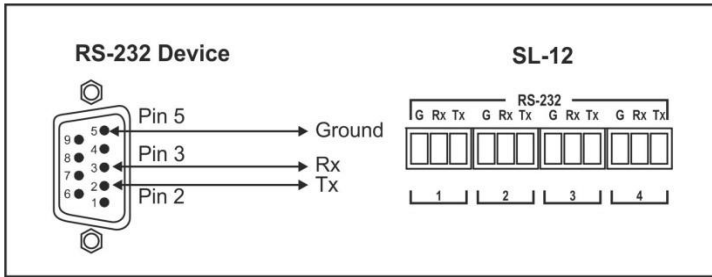

Figure 4: RS-232 Connection

4.4 Connecting the RS-485 Interface

To connect an AV device to the **SL-12** using the RS-485 port, connect the RS-485 port on your device to the RS-485 terminal block on the rear panel of the **SL-12** as shown in [Figure 5](#):

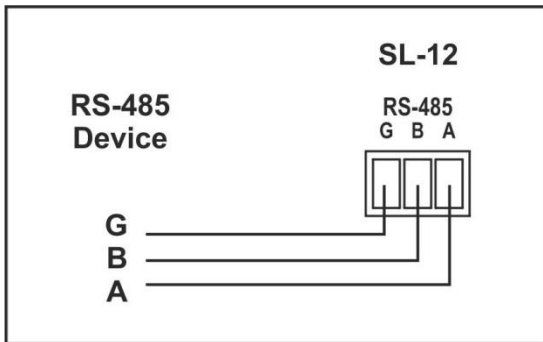

Figure 5: RS-485 Connection

4.5 Connecting the Ethernet Port

The Ethernet connection of the **SL-12** allows you to perform all control functions of the **SL-12** over the Internet using a PC running the Kramer Site-CTRL control program.

To connect the **SL-12** to a network:

1. Connect the Ethernet port of the **SL-12** to the Ethernet port on a network hub or network router, via a straight cable with RJ-45 connectors.

2. At the other end, connect the Internet to a PC running Site-CTRL.

After connecting the Ethernet port, you have to install and configure it. For detailed instructions on how to install and configure your Ethernet port, see the **K-Config Guide**

Available for download at the Kramer Web site: www.kramerav.com.

4.6 Connecting the K-NET Port

The K-NET port is wired as shown in [Figure 6](#).

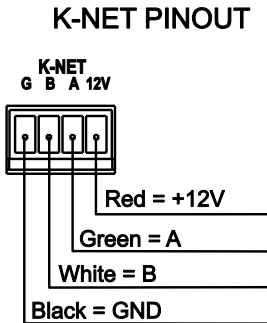

Figure 6: K-NET Pinout Connection

5 Operating the SL-12

You can operate your **SL-12** using:

- An RC family remote controller:
To operate your device using an RC remote controller, see the Kramer **K-Config Guide**
Available for download at the Kramer Web site: www.kramerav.com
- The optional **RC-4** infrared remote control transmitter:
The RC-4 is configured via the Kramer K-Config software
To operate your device using the infrared remote controller, see the User Manual packed with the remote controller
- A PC running **Site-CTRL** control software:
To operate your device using **Site-CTRL**, see the **Site-CTRL and Web Access Online User Guide**

6 Technical Specifications

BIDIRECTIONAL PORTS:	1 RS-485 and 4 RS-232 serial on 3-pin terminal blocks, 4 GPIO on 2-pin terminal blocks, 1 K-NET on 4-pin terminal block connector, 1 Ethernet on an RJ-45 connector, 1 Mini USB connector for local programming services, 1 built-in IR sensor and 2 IR-in on 3.5mm mini-jack (for learning).
INPUTS:	1 built-in IR sensor 2 IR-in on 3.5mm mini-jack (for learning)
OUTPUTS:	4 IR-out and 8 relays (36V AC or DC, 2A, 60VAC maximum on non-inductive load) on 2-pin terminal block connectors.
INDICATORS:	LED indicator for each port and function.
POWER CONSUMPTION:	12V DC, 550mA
OPERATING TEMPERATURE:	0° to +40°C (32° to 104°F)
STORAGE TEMPERATURE:	-40° to +70°C (-40° to 158°F)
HUMIDITY:	10% to 90%, RHL non-condensing
DIMENSIONS:	14.3cm x 12.2cm x 4.4cm (5.6" x 4.8" x 1.7") W, D, H
WEIGHT:	0.6kg (1.4lbs)
SHIPPING DIMENSIONS:	31.9cm x 16.5cm x 6.7cm (12.6" x 6.5" x 2.6") W, D, H
SHIPPING WEIGHT:	1kg (2.2lbs)
ACCESSORIES:	Power supply
OPTIONS:	RK-13 19" rack mount, RC-4 remote controller, IR emitter cables (P/N: C-A35/IRE-10; two IR Emitter Extension Cables are also available: a 15 meter cable and a 20 meter cable), IR sensor cable (P/N: 95-0104050)
Specifications are subject to change without notice at www.kramerav.com	

The warranty obligations of Kramer Electronics Inc. ("Kramer Electronics") for this product are limited to the terms set forth below:

What is Covered

This limited warranty covers defects in materials and workmanship in this product.

What is Not Covered

This limited warranty does not cover any damage, deterioration or malfunction resulting from any alteration, modification, improper or unreasonable use or maintenance, misuse, abuse, accident, neglect, exposure to excess moisture, fire, improper packing and shipping (such claims must be presented to the carrier), lightning, power surges, or other acts of nature. This limited warranty does not cover any damage, deterioration or malfunction resulting from the installation or removal of this product from any installation, any unauthorized tampering with this product, any repairs attempted by anyone unauthorized by Kramer Electronics to make such repairs, or any other cause which does not relate directly to a defect in materials and/or workmanship of this product. This limited warranty does not cover cartons, equipment enclosures, cables or accessories used in conjunction with this product.

Without limiting any other exclusion herein, Kramer Electronics does not warrant that the product covered hereby, including, without limitation, the technology and/or integrated circuit(s) included in the product, will not become obsolete or that such items are or will remain compatible with any other product or technology with which the product may be used.

How Long this Coverage Lasts

The standard limited warranty for Kramer products is seven (7) years from the date of original purchase, with the following exceptions:

1. All Kramer VIA products are covered by a standard three (3) year warranty for VIA hardware and a standard one (1) year warranty for firmware and software updates. (An extended software warranty plan for an additional 2 years can be purchased separately).
2. All Kramer fiber optic cables and adapters, all Kramer speakers and Kramer touch panels are covered by a standard one (1) year warranty.
3. All Kramer Cobra products, all Kramer Calibre products, all Kramer Minicomp digital signage products, all HighSecLabs products, all streaming, and all wireless products are covered by a standard three (3) year warranty.
4. All Sierra Video MultiViewers are covered by a standard five (5) year warranty.
5. Sierra switchers & control panels are covered by a standard seven (7) year warranty (excluding power supplies and fans that are covered for three (3) years).
6. K-Touch software is covered by a standard one (1) year warranty for software updates.
7. All Kramer passive cables are covered by a ten (10) year warranty.

Who is Covered

Only the original purchaser of this product is covered under this limited warranty. This limited warranty is not transferable to subsequent purchasers or owners of this product.

What Kramer Electronics Will Do

Kramer Electronics will, at its sole option, provide one of the following three remedies to whatever extent it shall deem necessary to satisfy a proper claim under this limited warranty:

1. Elect to repair or facilitate the repair of any defective parts within a reasonable period of time, free of any charge for the necessary parts and labor to complete the repair and restore this product to its proper operating condition. Kramer Electronics will also pay the shipping costs necessary to return this product once the repair is complete.
2. Replace this product with a direct replacement or with a similar product deemed by Kramer Electronics to perform substantially the same function as the original product.
3. Issue a refund of the original purchase price less depreciation to be determined based on the age of the product at the time remedy is sought under this limited warranty.

What Kramer Electronics Will Not Do Under This Limited Warranty

If this product is returned to Kramer Electronics or the authorized dealer from which it was purchased or any other party authorized to repair Kramer Electronics products, this product must be insured during shipment, with the insurance and shipping charges prepaid by you. If this product is returned uninsured, you assume all risks of loss or damage during shipment. Kramer Electronics will not be responsible for any costs related to the removal or re-installation of this product from or into any installation. Kramer Electronics will not be responsible for any costs related to any setting up this product, any adjustment of user controls or any programming required for a specific installation of this product.

How to Obtain a Remedy Under This Limited Warranty

To obtain a remedy under this limited warranty, you must contact either the authorized Kramer Electronics reseller from whom you purchased this product or the Kramer Electronics office nearest you. For a list of authorized Kramer Electronics resellers and/or Kramer Electronics authorized service providers, visit our web site at www.kramerav.com or contact the Kramer Electronics office nearest you.

In order to pursue any remedy under this limited warranty, you must possess an original, dated receipt as proof of purchase from an authorized Kramer Electronics reseller. If this product is returned under this limited warranty, a return authorization number, obtained from Kramer Electronics, will be required (RMA number). You may also be directed to an authorized reseller or a person authorized by Kramer Electronics to repair the product.

If it is decided that this product should be returned directly to Kramer Electronics, this product should be properly packed, preferably in the original carton, for shipping. Cartons not bearing a return authorization number will be refused.

Limitation of Liability

THE MAXIMUM LIABILITY OF KRAMER ELECTRONICS UNDER THIS LIMITED WARRANTY SHALL NOT EXCEED THE ACTUAL PURCHASE PRICE PAID FOR THE PRODUCT. TO THE MAXIMUM EXTENT PERMITTED BY LAW, KRAMER ELECTRONICS IS NOT RESPONSIBLE FOR DIRECT, SPECIAL, INCIDENTAL OR CONSEQUENTIAL DAMAGES RESULTING FROM ANY BREACH OF WARRANTY OR CONDITION, OR UNDER ANY OTHER LEGAL THEORY. Some countries, districts or states do not allow the exclusion or limitation of relief, special, incidental, consequential or indirect damages, or the limitation of liability to specified amounts, so the above limitations or exclusions may not apply to you.

Exclusive Remedy

TO THE MAXIMUM EXTENT PERMITTED BY LAW, THIS LIMITED WARRANTY AND THE REMEDIES SET FORTH ABOVE ARE EXCLUSIVE AND IN LIEU OF ALL OTHER WARRANTIES, REMEDIES AND CONDITIONS, WHETHER ORAL OR WRITTEN, EXPRESS OR IMPLIED. TO THE MAXIMUM EXTENT PERMITTED BY LAW, KRAMER ELECTRONICS SPECIFICALLY DISCLAIMS ANY AND ALL IMPLIED WARRANTIES, INCLUDING, WITHOUT LIMITATION, WARRANTIES OF MERCHANTABILITY AND FITNESS FOR A PARTICULAR PURPOSE. IF KRAMER ELECTRONICS CANNOT LAWFULLY DISCLAIM OR EXCLUDE IMPLIED WARRANTIES UNDER APPLICABLE LAW, THEN ALL IMPLIED WARRANTIES COVERING THIS PRODUCT, INCLUDING WARRANTIES OF MERCHANTABILITY AND FITNESS FOR A PARTICULAR PURPOSE, SHALL APPLY TO THIS PRODUCT AS PROVIDED UNDER APPLICABLE LAW.

IF ANY PRODUCT TO WHICH THIS LIMITED WARRANTY APPLIES IS A "CONSUMER PRODUCT" UNDER THE MAGNUSON-MOSS WARRANTY ACT (15 U.S.C.A. §2301, ET SEQ.) OR OTHER APPLICABLE LAW, THE FOREGOING DISCLAIMER OF IMPLIED WARRANTIES SHALL NOT APPLY TO YOU, AND ALL IMPLIED WARRANTIES ON THIS PRODUCT, INCLUDING WARRANTIES OF MERCHANTABILITY AND FITNESS FOR THE PARTICULAR PURPOSE, SHALL APPLY AS PROVIDED UNDER APPLICABLE LAW.

Other Conditions

This limited warranty gives you specific legal rights, and you may have other rights which vary from country to country or state to state.

This limited warranty is void if (i) the label bearing the serial number of this product has been removed or defaced, (ii) the product is not distributed by Kramer Electronics or (iii) this product is not purchased from an authorized Kramer Electronics reseller. If you are unsure whether a reseller is an authorized Kramer Electronics reseller, visit our web site at www.kramerav.com or contact a Kramer Electronics office from the list at the end of this document.

Your rights under this limited warranty are not diminished if you do not complete and return the product registration form or complete and submit the online product registration form. Kramer Electronics thanks you for purchasing a Kramer Electronics product. We hope it will give you years of satisfaction



For the latest information on our products and a list of Kramer distributors, visit our Web site where updates to this user manual may be found.

We welcome your questions, comments, and feedback.

Web site: www.kramerav.com

E-mail: info@kramerel.com



SAFETY WARNING

Disconnect the unit from the power supply before opening and servicing



P/N: 2900-000552



Rev: 7