



# LaCie 6big & 12big Thunderbolt 3 User Manual

---



**Click here to access an up-to-date online version** of this document. You will also find the most recent content as well as expandable illustrations, easier navigation, and search capability.

# Contents

<b>1</b>	<b>Regulatory Compliance</b>	<b>6</b>
	FCC Declaration of Conformance	6
	FCC Class A Information	6
	FCC Caution	6
	Important Note: FCC Radiation Exposure Statement	6
	Industry Canada	7
	Important Note for mobile device use	7
	Note Importante pour l'utilisation de dispositifs mobiles	7
	Europe – EU Declaration of Conformity	7
	Power source	9
<b>2</b>	<b>Introduction</b>	<b>10</b>
	Box content	10
	Minimum computer system requirements	10
	• Thunderbolt 3	10
	• USB	11
	Computer hardware requirements	11
	• Thunderbolt 3	11
	• SuperSpeed USB 3.1 Gen 2	11
	• SuperSpeed USB 3.1 Gen 1	11
	• SuperSpeed USB 3.0	11
	• Hi-Speed USB 2.0	11
<b>3</b>	<b>LaCie 6big/LaCie 12big Advanced Storage</b>	<b>12</b>
	LaCie 6big and LaCie 12big	12
	Hardware RAID	12
	Thunderbolt 3	12
<b>4</b>	<b>System Overview</b>	<b>14</b>
	Storage management	14
	Specifications – LaCie 12big Thunderbolt 3	14
	• Enclosure dimensions	14
	• Enclosure weight	14
	• Temperature ranges	15
	• Humidity	15
	• Electrical	15
	Specifications – LaCie 6big Thunderbolt 3	15
	• Enclosure dimensions	15
	• Enclosure weight	15
	• Temperature ranges	16
	• Humidity	16

• Electrical .....	16
Views .....	16
• Front and side views .....	16
• Rear panel view .....	17
<b>5 System LEDs .....</b>	<b>19</b>
LED locations .....	19
LED behavior .....	19
• General LED behavior .....	19
<b>6 Cables .....</b>	<b>21</b>
USB-C .....	21
• Easy to connect .....	21
Thunderbolt 3 (USB-C) cable .....	21
USB 3.1 (USB-C Gen 2) cable .....	22
USB 3.1 (USB-C)-to-USB Type A cable .....	22
<b>7 Connect your LaCie 6big/LaCie 12big Thunderbolt 3 .....</b>	<b>24</b>
Windows and Thunderbolt 3 .....	24
Step 1 - Download and install LaCie RAID Manager .....	24
Step 2 - Connect LaCie 6big/LaCie 12big to your computer .....	25
• Thunderbolt 3 connection .....	25
• USB 3.1 Gen 2 connection .....	25
• PC or Mac with a USB-C port .....	25
• PC or Mac with a USB 3.0 or USB 2.0 port (Type A) .....	26
Step 3 - Power connection .....	27
Step 4 - Power switch .....	27
Format LaCie 6big/12big storage .....	28
<b>8 Operation .....</b>	<b>29</b>
Powering off the LaCie 6big/LaCie 12big hard drives: idle mode .....	29
Powering off the LaCie 6big/LaCie 12big enclosure .....	29
Short push .....	30
• Short push and RAID synchronization/initialization .....	30
Long push .....	30
Removing the Thunderbolt cable during operation .....	30
Quiet operation and heat management .....	30
Position and stacking .....	31
<b>9 Daisy Chain and Power Delivery .....</b>	<b>32</b>
Daisy chain Thunderbolt 3 devices .....	32
How to daisy chain .....	32
• Daisy chain: idle mode .....	33

Power delivery .....	33
<b>10 Software .....</b>	<b>34</b>
<b>11 RAID .....</b>	<b>35</b>
Standard RAID levels .....	35
• RAID 0 .....	35
• RAID 1 .....	36
• RAID 5 .....	36
• RAID 6 .....	37
Nested RAID levels .....	38
• RAID 10 .....	38
• RAID 50 .....	39
• RAID 60 .....	39
• RAID+Spare .....	40
Drive failures and synchronizing a spare hard drive .....	40
<b>12 Hard Drive Maintenance .....</b>	<b>42</b>
Precautions .....	42
Replacing a hard drive .....	42
LaCie 6big/LaCie 12big enclosure: non-serviceable components .....	47
<b>13 Formatting and Partitioning .....</b>	<b>48</b>
About file system formats .....	48
Formatting instructions .....	48
• Windows .....	49
• Mac .....	49
<b>14 Frequently Asked Questions .....</b>	<b>50</b>
All users .....	50
• Problem: My file transfers are too slow. ....	50
• Thunderbolt 3/USB .....	50
• Thunderbolt 3 .....	50
• USB .....	50
• Problem: I connected LaCie 6big/LaCie 12big to my computer but it does not power on and I cannot see the device in LaCie RAID Manager. ....	50
• Problem: I want to change the RAID level. ....	51
• Problem: I disconnected my computer from the LaCie 6big/12big during RAID synchronization or initialization. ....	51
• Problem: I have a USB-C hard drive that I want to add to the Thunderbolt 3 daisy chain. ....	51
• Problem: I see two or more arrays in LaCie RAID Manager but only one is available on my computer. ....	52
• Problem: I must password protect and/or encrypt my hard drive. ....	52
• Problem: I'm receiving file transfer error messages. ....	52
Mac .....	52

- Problem: The drive icon does not appear on my desktop. .... 53
- Windows** ..... 53
- Problem: The drive icon doesn't appear in Computer. .... 53

# Regulatory Compliance

## FCC Declaration of Conformance

This device complies with Part 15 of the FCC Rules. Operation is subject to the following two conditions: (1) this device may not cause harmful interference, and (2) this device must accept any interference received, including interference that may cause undesired operation.

## FCC Class A Information

This equipment has been tested and found to comply with the limits for a Class A digital device, pursuant to Part 15 of the FCC Rules. These limits are designed to provide reasonable protection against harmful interference in a residential installation. This equipment generates, uses and can radiate radio frequency energy and, if not installed and used in accordance with the instructions, may cause harmful interference to radio communications. However, there is no guarantee that interference will not occur in a particular installation.

If this equipment does cause harmful interference to radio or television reception, which can be determined by turning the equipment off and on, the user is encouraged to try to correct the interference by one of the following measures:

- Reorient or relocate the receiving antenna.
- Increase the separation between the equipment and receiver.
- Connect the equipment into an outlet on a circuit different from that to which the receiver is connected.
- Consult the dealer or an experienced radio/TV technician for help.

This device complies with Part 15 of the FCC Rules. Operation is subject to the following two conditions: (1) This device may not cause harmful interference, and (2) this device must accept any interference received, including interference that may cause undesired operation.

## FCC Caution

Any changes or modifications not expressly approved by the party responsible for compliance could void the user's authority to operate this equipment.

## Important Note: FCC Radiation Exposure Statement

This equipment complies with FCC radiation exposure limits set forth for an uncontrolled environment. This equipment should be installed and operated with minimum distance 20cm between the radiator and your body. This transmitter must not be co-located or operating in conjunction with any other antenna or

transmitter. The availability of some specific channels and/or operational frequency bands are country dependent and are firmware programmed at the factory to match the intended destination. The firmware setting is not accessible by the end user.

## Industry Canada

This device complies with RSS-210 of the Industry Canada Rules. Operation is subject to the following two conditions: (1) This device may not cause harmful interference, and (2) this device must accept any interference received, including interference that may cause undesired operation.

Ce dispositif est conforme à la norme CNR-210 d'Industrie Canada applicable aux appareils radio exempts de licence. Son fonctionnement est sujet aux deux conditions suivantes: (1) le dispositif ne doit pas produire de brouillage préjudiciable, et (2) ce dispositif doit accepter tout brouillage reçu, y compris un brouillage susceptible de provoquer un fonctionnement indésirable.

## Important Note for mobile device use

**Radiation Exposure Statement:** This equipment complies with IC radiation exposure limits set forth for an uncontrolled environment. This equipment should be installed and operated with minimum distance 20cm between the radiator & your body.

## Note Importante pour l'utilisation de dispositifs mobiles

**Déclaration d'exposition aux radiations:**

Cet équipement est conforme aux limites d'exposition aux rayonnements IC établies pour un environnement non contrôlé. Cet équipement doit être installé et utilisé avec un minimum de 20 cm de distance entre la source de rayonnement et votre corps.

## Europe – EU Declaration of Conformity

This device complies with the essential requirements of the EMC Directive 2004/108/EC. The following test methods have been applied in order to prove presumption of conformity with the essential requirements of the EMC Directive 2004/108/EC:

- EN 60950-1:2006/AC:2011: Information technology equipment - Safety - Part 1: General requirements
- EN 55022: 2010/AC:2011: Information technology equipment - Radio disturbance characteristics
  - Limits and methods of measurement
- EN 55024: 2010: Information technology equipment - Immunity characteristics - Limits and methods of measurement

Česky [Czech]	LaCie tímto prohlašuje, že tento direct attached storage device je ve shodě se základními požadavky a dalšími příslušnými ustanoveními směrnice 2004/5/ES.
Dansk [Danish]	Undertegnede LaCie erklærer herved, at følgende udstyr direct attached storage device overholder de væsentlige krav og øvrige relevante krav i direktiv 2004/5/EF.
Deutsch [German]	Hiermit erklärt LaCie, dass sich das Gerät direct attached storage device in Übereinstimmung mit den grundlegenden Anforderungen und den übrigen einschlägigen Bestimmungen der Richtlinie 2004/5/EG befindet.
Eesti [Estonian]	Käesolevaga kinnitab LaCie seadme direct attached storage device vastavust direktiivi 2004/5/EÜ põhinõuetele ja nimetatud direktiivist tulenevatele teistele asjakohastele sätetele.
English	Hereby, LaCie, declares that this direct attached storage device is in compliance with the essential requirements and other relevant provisions of Directive 2004/5/EC.
Español [Spanish]	Por medio de la presente LaCie declara que el direct attached storage device cumple con los requisitos esenciales y cualesquiera otras disposiciones aplicables o exigibles de la Directiva 2004/5/CE.
Ελληνική [Greek]	ΜΕ ΤΗΝ ΠΑΡΟΥΣΑ LaCie ΔΗΛΩΝΕΙ direct attached storage device ΣΥΜΜΟΡΦΩΝΕΤΑΙ ΠΡΟΣ ΤΙΣ ΟΥΣΙΩΔΕΙΣ ΑΠΑΙΤΗΣΕΙΣ ΚΑΙ ΤΙΣ ΛΟΙΠΕΣ ΣΧΕΤΙΚΕΣ ΔΙΑΤΑΞΕΙΣ ΤΗΣ ΟΔΗΓΙΑΣ 2004/5/ΕΚ.
Français [French]	Par la présente LaCie déclare que l'appareil direct attached storage device est conforme aux exigences essentielles et aux autres dispositions pertinentes de la directive 2004/5/CE.
Italiano [Italian]	Con la presente LaCie dichiara che questo direct attached storage device è conforme ai requisiti essenziali ed alle altre disposizioni pertinenti stabilite dalla direttiva 2004/5/CE.
Latviski [Latvian]	Ar šo LaCie deklarē, ka direct attached storage device atbilst Direktīvas 2004/104/EK būtiskajām prasībām un citiem ar to saistītajiem noteikumiem.
Lietuvių [Lithuanian]	Šiuo LaCie deklaruoja, kad šis direct attached storage device atitinka esminius reikalavimus ir kitas 2004/104/EB Direktyvos nuostatas.
Nederlands [Dutch]	Hierbij verklaart LaCie dat het toestel direct attached storage device in overeenstemming is met de essentiële eisen en de andere relevante bepalingen van richtlijn 2004/104/EG.
Malti [Maltese]	Hawnhekk, LaCie, jiddikjara li dan direct attached storage device jikkonforma mal-ħtiġijiet essenzjali u ma provvedimenti oħrajn rilevanti li hemm fid-Dirrettiva 2004/104/EC.
Magyar [Hungarian]	Alulírott, LaCie nyilatkozom, hogy a direct attached storage device megfelel a vonatkozó alapvető követelményeknek és az 2004/104/EC irányelv egyéb előírásainak.
Polski [Polish]	Niniejszym LaCie oświadcza, że direct attached storage device jest zgodny z zasadniczymi wymogami oraz pozostałymi stosownymi postanowieniami Dyrektywy 2004/104/EC.
Português [Portuguese]	LaCie declara que este direct attached storage device está conforme com os requisitos essenciais e outras disposições da Directiva 2004/104/CE.



Slovensko [Slovenian]	LaCie izjavlja, da je at direct attached storage device v skladu z bistvenimi zahtevami in ostalimi relevantnimi določili direktive 2004/104/ES.
Slovensky [Slovak]	LaCie týmto vyhlasuje, že direct attached storage device spĺňa základné požiadavky a všetky príslušné ustanovenia Smernice 2004/104/ES.
Suomi [Finnish]	LaCie vakuuttaa täten että direct attached storage device tyyppinen laite on direktiivin 2004/104/EY oleellisten vaatimusten ja sitä koskevien direktiivin muiden ehtojen mukainen.
Svenska [Swedish]	Härmed intygar LaCie att denna direct attached storage device står i överensstämmelse med de väsentliga egenskapskrav och övriga relevanta bestämmelser som framgår av direktiv 2004/104/EG.

## Power source



**Caution:** Use the product with the provided power cable only.



**Note:** To protect your data, always follow the safe removal procedures for your operating system when disconnecting your product.

# Introduction

Welcome to the user manual for LaCie 6big Thunderbolt 3 and LaCie 12big Thunderbolt 3. When connected to a computer that supports Thunderbolt 3, LaCie 6big and LaCie 12big can attain transfer rates up to 40Gb/s. LaCie 6big and LaCie 12big are ideal for professional editors, photographers and graphic artists who work with bandwidth-intensive content such as 4K video and 3D graphics.

Review this user manual to learn how to configure and manage your LaCie 6big and LaCie 12big. For common questions and answers about your device, please see [Frequently Asked Questions](#).

You can get the latest tips regarding your product and updated technical information at [LaCie customer support](#).

## Box content

- LaCie 6big Thunderbolt 3 or LaCie 12big Thunderbolt 3
- Power cable
- Thunderbolt 3 (USB-C) cable
- USB 3.1 (USB-C) cable
- USB 3.1 (USB-C) to USB 3.0/USB 2.0 adapter cable (compatible with Type A ports)
- Quick Install Guide
- Software: LaCie RAID Manager, Intego Backup Manager Pro, Genie Backup Manager Pro and LaCie Private-Public

Software can be downloaded at [LaCie.com](#).



**Important info:** Save your packaging. In the event that the hard drive enclosure should need to be repaired or serviced, it must be returned in its original packaging.

## Minimum computer system requirements

The minimum operating system for your computer differs based upon the port you are using. Choose your port and connect your LaCie device to a computer that meets the following minimum system requirements.

### Thunderbolt 3

- macOS Sierra or higher
- Windows 10 or higher

# USB

- Mac OS X 10.10 or higher
- Windows 8.1 or higher

## Computer hardware requirements

You can connect your LaCie device to a computer that supports one of the following interfaces.

### Thunderbolt 3

Transfer rates can reach up to 40Gb/s.

### SuperSpeed USB 3.1 Gen 2

Transfer rates can reach up to 10Gb/s.

### SuperSpeed USB 3.1 Gen 1

Transfer rates can reach up to 5Gb/s.

### SuperSpeed USB 3.0

Transfer rates can reach up to 5Gb/s.

### Hi-Speed USB 2.0

Transfer rates can reach up to 480 Mb/s.

# LaCie 6big/LaCie 12big Advanced Storage

## LaCie 6big and LaCie 12big

LaCie 6big and LaCie 12big give you high-end performance for your increasingly demanding projects. Feature highlights include:

- Hot-swappable enterprise-class hard drives (7200RPM 64MB cache)
- 2x Thunderbolt 3 ports, up to 40Gb/s bi-directional per port and daisy chain
- 1x USB 3.1 Gen 2 port, universal compatibility and up to 10Gb/s
- Heat-dissipating all-aluminum enclosure
- RAID-on-Chip (RoC) processor to manage the RAID
- Hardware RAIDs 0, 1, 10, 5, 50, 6, 60
- Intelligent RAID rebuild with a spare drive
- Six SATA channels, up to 6Gb/s per channel
- Hot-swappable hard drives to reduce downtime
- A warning system with audible and email alerts

## Hardware RAID

LaCie 6big and LaCie 12big offer both extraordinary performance and built-in protection. Their powerful RAID engines save your computer from expending critical processing resources on storage management, which is crucial for video and graphics applications that place heavy demands on computer CPUs. Further, hardware RAID solutions offer advanced RAID configurations to suit the needs of your working environment.

## Thunderbolt 3

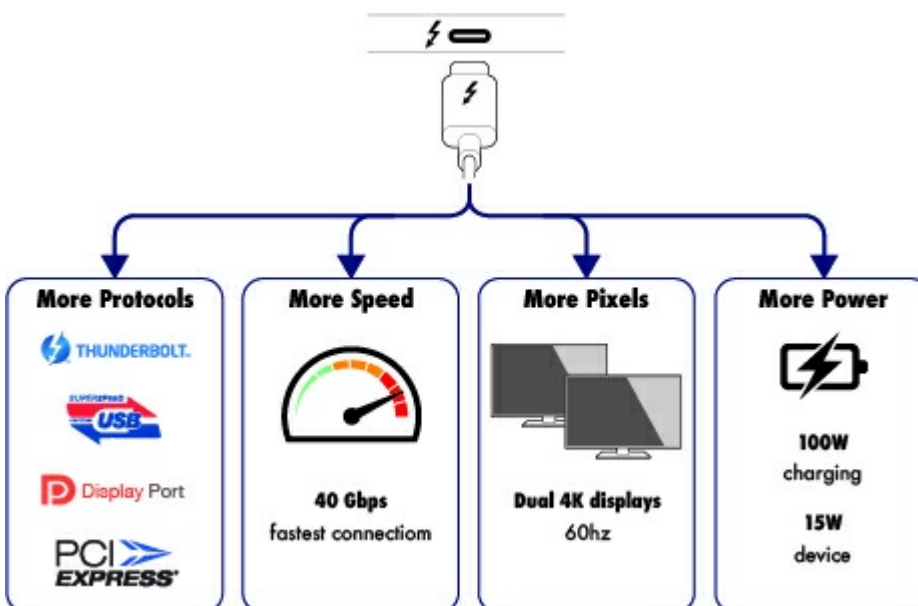

## Thunderbolt 3 features and support

Thunderbolt 3 technology provides the fastest data and high-end video transfers over a single, versatile connector. While previous generations of Thunderbolt technology offered impressive transfer rates up to 20Gb/s bi-directional, Thunderbolt 3 doubles the potential up to 40Gb/s bi-directional when connected to other Thunderbolt 3 devices. Further, Thunderbolt 3 gives priority to the video stream, apportioning the required bandwidth for playback. This is a critical advantage when working with high-end video and 3D graphics.

Thunderbolt 3 uses a USB-C connector specially labeled with a thunderbolt icon. Since Thunderbolt 3 is protocol agnostic, it supports connections from the following interfaces:

- USB 2.0, USB 3.0 and USB 3.1
- DisplayPort 1.1 and 1.2a
- Thunderbolt 20Gb/s and Thunderbolt 40Gb/s
- Ethernet (with adapter)

Non-Thunderbolt 3 devices that feature USB-C ports can be connected to the Thunderbolt 3 port to terminate a daisy chain and, if compatible, to take advantage of the power delivery option for charging batteries.

# System Overview

LaCie 6big and LaCie 12big are desktop hard drive enclosures that house up to six and twelve 3.5-inch hard drives, respectively.

Enclosures shipped with hard drives feature high-performance Seagate enterprise-class hard drives. In case of hard drive failure or, the need to expand storage capacity, each individual hard drive is hot-swappable and field replaceable. New or replacement hard drives must meet the following minimum requirements:

- SATA I or higher
- 3.0Gb/s or higher
- Spin up to 7200 RPM
- 64MB cache or greater

## Storage management

LaCie 6big and LaCie 12big storage is managed by the software utility LaCie RAID Manager. See [Software](#) for more information.

## Specifications – LaCie 12big Thunderbolt 3

### Enclosure dimensions

Side	Dimensions (mm / in)
Width	161 / 6.3
Height	447 / 17.6
Length	237 / 9.3

### Enclosure weight

Hard drives	Weight (Kg / lbs.)
12x 4TB (48TB)	16.4 / 36.2
12x 6TB (72TB)	17.6 / 38.9
12x 8TB (96TB)	17.6 / 38

## Temperature ranges

Ambient environment	Temperature range
Standard (operating)	+5°C to +40°C
Storage (non-operating)	-20°C to +60°C

## Humidity

Environment	Humidity range
Standard (operating)	10% to 60% non-condensing
Storage (non-operating)	5% to 85% non-condensing

## Electrical

Power supply: 100-240VAC; 50/60Hz; 140W up to 250W



Note on the power supply: Use the included power cable with the LaCie 12big Thunderbolt 3.

## Specifications – LaCie 6big Thunderbolt 3

### Enclosure dimensions

Side	Dimensions (mm / in)
Width	161 / 6.3
Height	225 / 8.9
Length	237 / 9.3

### Enclosure weight

Hard drives	Weight (Kg / lbs.)
6x 4TB (24TB)	9.3 / 20.5
6x 6TB (36TB)	9.9 / 21.8
6x 8TB (48TB)	9.9 / 21.8

# Temperature ranges

Ambient environment	Temperature range
Standard (operating)	+5°C to +40°C
Storage (non-operating)	-20°C to +60°C

# Humidity

Environment	Humidity range
Standard (operating)	10% to 60% non-condensing
Storage (non-operating)	5% to 85% non-condensing

# Electrical

Power supply: 100-240VAC; 50/60Hz; 85W up to 150W



Note on the power supply: Use the included power cable with the LaCie 6big Thunderbolt 3.

# Views

## Front and side views

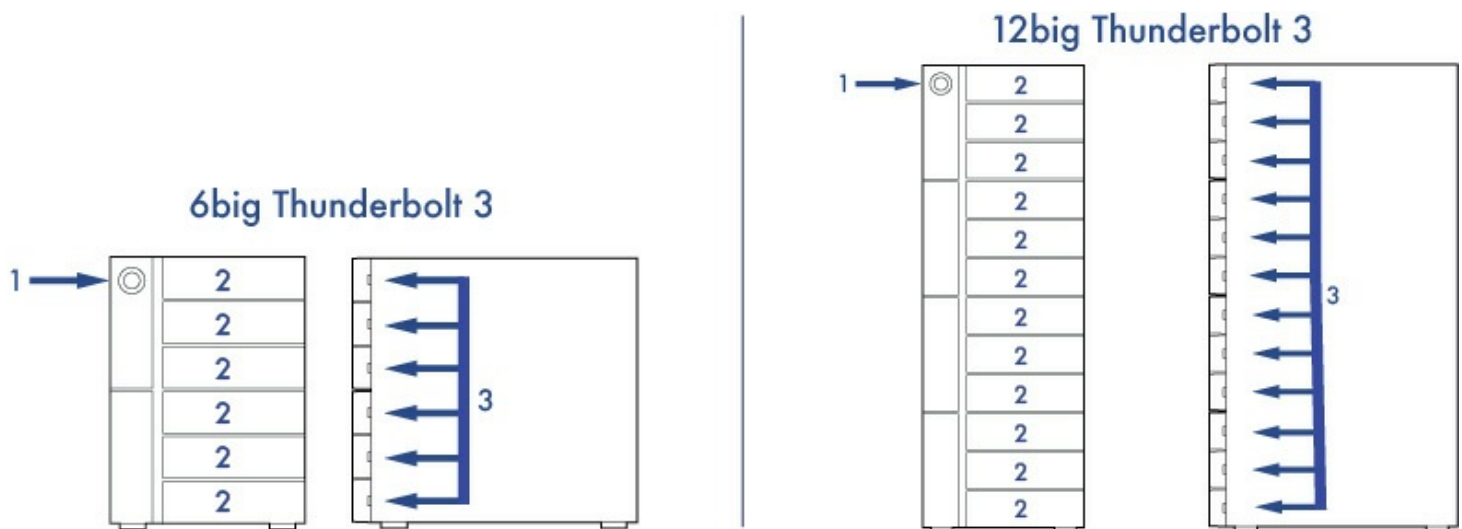

- Status LED/power button:** The LED indicates that the device is powered on and provides status signals (see [System LEDs](#)). It is also the power button. A short push spins down LaCie 6big's/12big's hard drives and places the system into idle mode. A long push is only for emergency use since it cuts power to the system without spinning the hard drives down. See [Operation](#) for more details.
- Swappable hard drive trays:** Hard drive trays can be removed to replace failed hard drives. The LaCie



6big and 12big hard drives are hot-swappable.

3. **Hard drive status LEDs:** Indicates hard drive activity and health (see [System LEDs](#)).

## Rear panel view

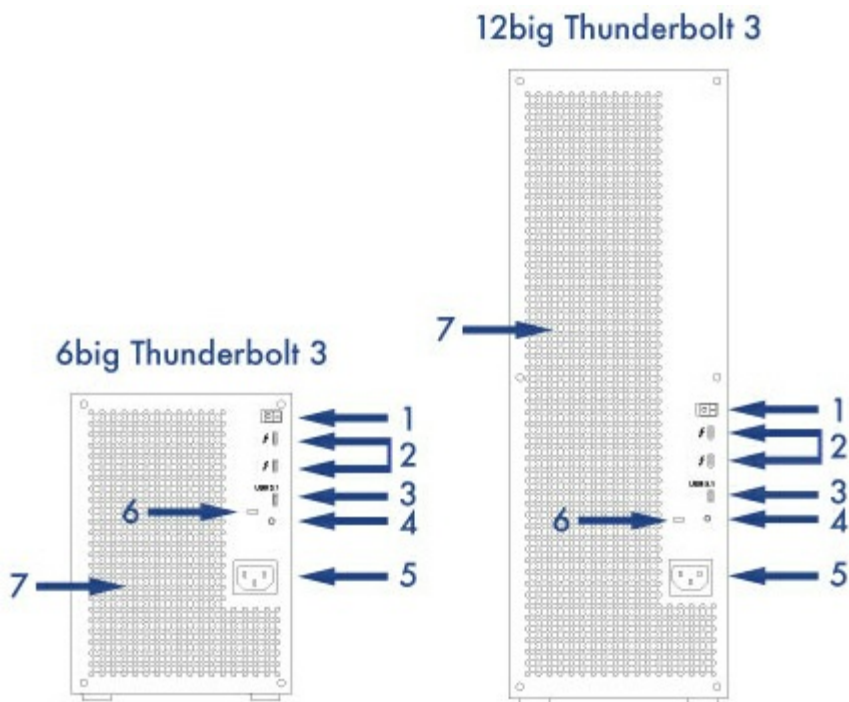

1. **Power switch:** Push I to power on the device. The device must also be connected to a computer that is powered on.
2. **Thunderbolt 3 ports:** Use the included Thunderbolt 3 cable to connect to a Thunderbolt 3 port on your computer or other Thunderbolt 3 devices. Since the ports on the LaCie device are not preconfigured with specific roles, you can use either port as the host (connected to a computer), as part of a daisy chain (connected to other compatible devices) or for power delivery to compatible devices. See [Connect your LaCie 6big/LaCie 12big Thunderbolt 3](#) and [Daisy Chain](#).



**Note:** The Thunderbolt 3 and USB 3.1 ports cannot be used at the same time.

3. **USB 3.1 port:** Use one of the included USB cables to connect this port to a USB port on your computer. You can connect LaCie 6big/LaCie 12big to a computer with a USB 3.1 (USB-C) port or a USB 3.0/USB 2.0 (USB Type A) port. Transfer rates vary by the connection type.



**Note:** The Thunderbolt 3 and USB 3.1 ports cannot be used at the same time.

4. **Firmware update button:** Updates to the USB firmware are posted on the support page to enhance your product. Only press this button when following instructions to update the USB firmware. Use a small pointed object such as the end of a paper clip to push the button within the enclosed space.
5. **Power input:** Use this port to connect the power cable. Only use the power cable included with your LaCie 6big Thunderbolt 3 or LaCie 12big Thunderbolt 3. Attaching third-party or other LaCie power cables with incorrect voltage can damage the LaCie 6big Thunderbolt 3 and/or LaCie 12big Thunderbolt 3.

6. **Kensington™ lock port:** Use this port to physically lock LaCie 6big/LaCie 12big to a desk or rack.

# System LEDs

The LaCie 6big Thunderbolt 3/LaCie 12big Thunderbolt 3 LEDs provide information on the system status.

## LED locations

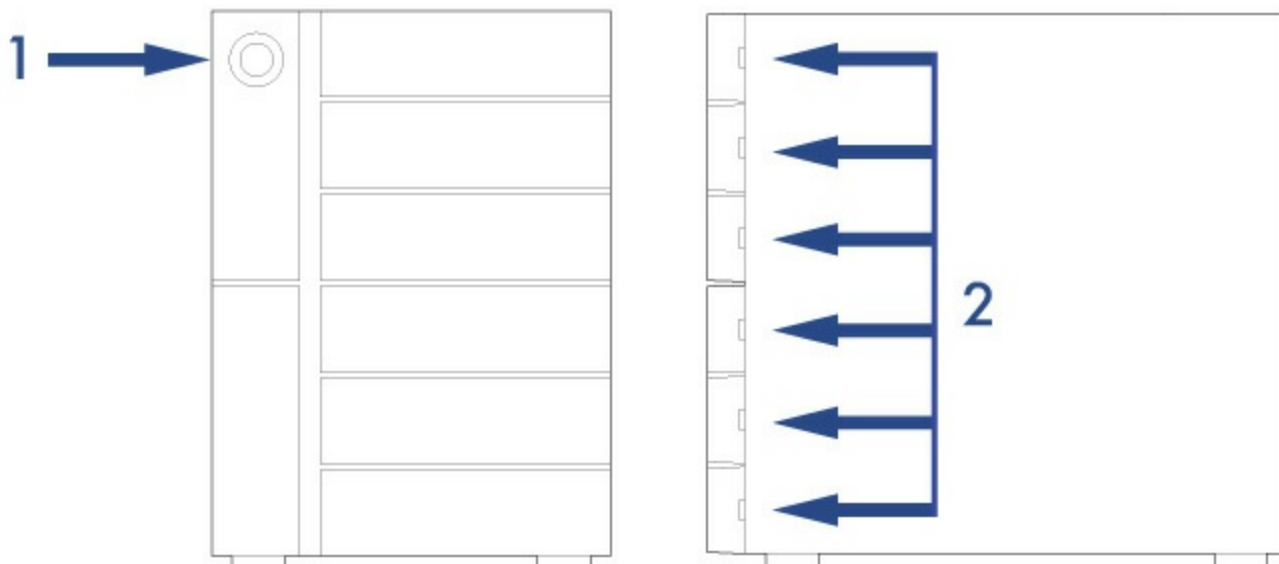

1. Front: system status
2. Side: hard drive status

## LED behavior

### General LED behavior

The list of colors below helps you identify the general status of your LaCie 6big/LaCie 12big.

Color	State
Solid blue	Ready
Blinking blue	Activity
Slow blinking blue	Sleep
Fast blinking blue	Startup and shutdown
Blinking red and blue	RAID initialization or synchronization

Blinking red	Warning
Solid red	Error

# Cables

## USB-C

USB 2.0 480 Mb/s	USB 3.1 5 Gb/s	USB 3.1 10 Gb/s	DisplayPort Multi-Function 5 or 10 Gb/s	Thunderbolt 3 20 or 40 Gb/s
				

### USB-C protocols

USB is a serial input/output technology for connecting peripheral devices to a computer. USB-C is the latest implementation of this standard and it provides convenient connector, higher bandwidth and all-new power management features. Further, USB-C ports that feature the Thunderbolt icon support Thunderbolt 3 devices.

USB-C supports many protocols:

- Thunderbolt 3: transfer rates up to 40Gb/s
- USB 3.1 Gen 2: transfer rates up to 10Gb/s
- USB 3.1 Gen 1: transfer rates up to 5Gb/s
- SuperSpeed USB 3.0: transfer rates up to 5Gb/s
- Hi-Speed USB 2.0: transfer rates up to 480Mb/s
- DisplayPort: up to 8K with compatible devices and backwards compatible to VGA and DVI

The USB-C ports on LaCie 6big/LaCie 12big are:

- Thunderbolt 3 (2 ports)
- USB 3.1 Gen 2 (1 port)

You can connect LaCie 6big/LaCie 12big to any USB-C or USB Type A port but transfer rates vary. See below for more details. Thunderbolt 3 includes support for DisplayPort up to 4K.



## Easy to connect

Connecting your product is easy since the USB-C cable is identical on both ends. Further, the USB-C ports on your LaCie hard drive enclosure and computer are conveniently rounded to accept the cable end no matter how it is connected.

## Thunderbolt 3 (USB-C) cable

Thunderbolt 3 can attain up to 40Gb/s as opposed to Thunderbolt 2's 20Gb/s.



Use the included Thunderbolt 3 (USB-C) cable to ensure maximum data transfer performance when used with compatible ports.

Connector face	Cable end
	

## USB 3.1 (USB-C Gen 2) cable

USB 3.1 Gen 2 can attain up to 10Gb/s as opposed to USB 3.0 at 5Gb/s and USB 2.0 at 480Mb/s.





Make certain to use the USB-C cable included with your device. Due to poor construction, many third-party USB-C cables can cause irreparable harm to devices such as your computer and LaCie device. LaCie is not responsible for damage to your LaCie 6big Thunderbolt 3 or LaCie 12big Thunderbolt 3 caused by third-party cables.

Connector face	Cable end
	

## USB 3.1 (USB-C)-to-USB Type A cable

Use the USB 3.1 (USB-C)-to-USB Type A cable for compatibility with computers that do not have a USB-C port. The USB-C end is connected to the LaCie hard drive and the Type A end is connected to the computer's USB 3.0 or USB 2.0 Type A port.

Hard drive performance is limited to USB 3.0 transfer rates when connected to a USB 3.0 port and, USB 2.0 transfer rates when connected to a USB 2.0 port.

Connector face (USB Type A to computer)	Cable end (USB Type A to computer)	Cable end (USB-C to product)	Connector face (USB-C to product)
			

# Connect your LaCie 6big/LaCie 12big Thunderbolt 3

The LaCie 6big Thunderbolt 3 and LaCie 12big Thunderbolt 3 are shipped with the following installation components:

- LaCie 6big Thunderbolt 3 / LaCie 12big Thunderbolt 3
- Power cable
- Thunderbolt 3 (USB-C) cable (Thunderbolt logo)
- USB 3.1 (USB-C) cable
- USB 3.1 (USB-C) to USB 3.0/USB 2.0 adapter cable (compatible with Type A ports)

The instructions below are also available on the Quick Install Guide included with the LaCie 6big/LaCie12big.

## Windows and Thunderbolt 3

Your LaCie Thunderbolt 3 storage device is certified for use with Windows PCs that have a Thunderbolt 3 port. However, you may experience connectivity issues between the storage device and the Thunderbolt 3 port on a Windows PC. Therefore, before setting up your LaCie Thunderbolt 3 storage device, please visit your PC manufacturer's website to update your Windows PC to the latest versions of:

- BIOS
- Thunderbolt 3 firmware
- Thunderbolt 3 driver

Also, make certain that your PC has the most recent version of Windows 10.

For questions regarding your PC, please contact the PC manufacturer. You can also review the following website for additional information: <https://thunderbolttechnology.net/updates>

This issue pertains to the Thunderbolt 3 port and does not affect USB ports.

## Step 1 - Download and install LaCie RAID Manager

LaCie RAID Manager is the application that manages the LaCie 6big/LaCie 12big storage. Before connecting the enclosure to your computer, download the installer for LaCie RAID Manager. The installer loads the application and the driver to recognize the Thunderbolt storage.

1. Download the installer at [LaCie RAID Manager](#).
2. Launch the installer on the computer that will connect to the LaCie 6big/LaCie 12big.
3. Follow the on-screen instructions to complete the installation.



# Step 2 – Connect LaCie 6big/LaCie 12big to your computer

## Thunderbolt 3 connection

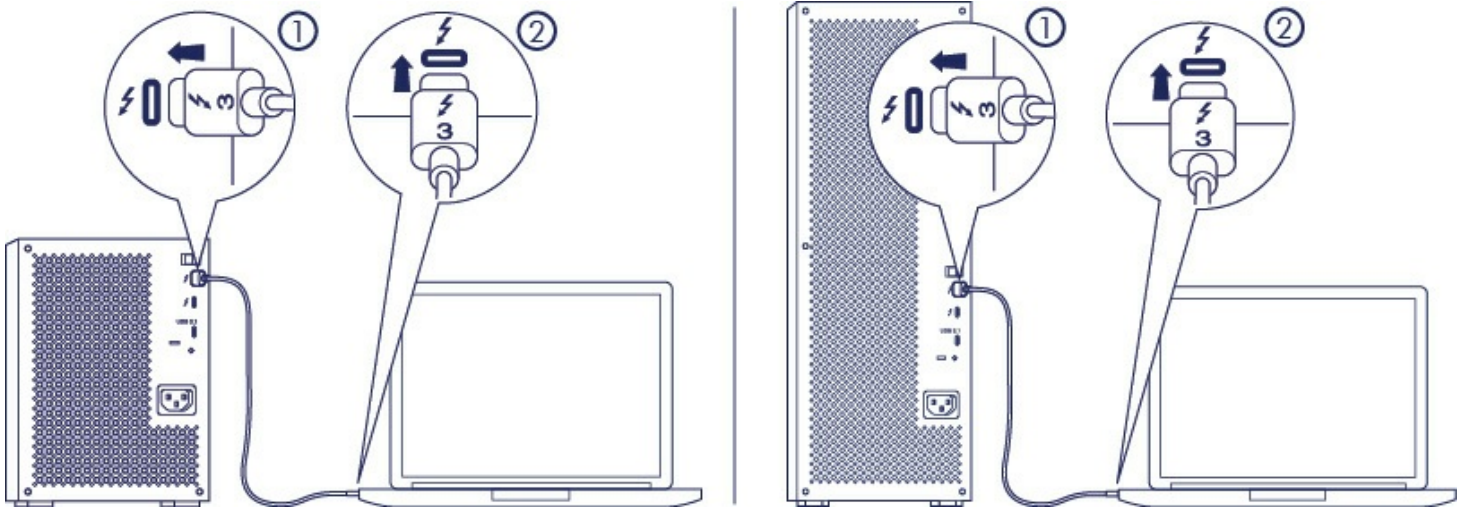

Connect the included Thunderbolt 3 cable to:

1. LaCie 6big/12big
2. PC or Mac



**Note on a Thunderbolt daisy chain:** You can also connect a second Thunderbolt 3 cable to daisy chain compatible devices to LaCie 6big/LaCie 12big. A Thunderbolt daisy chain supports up to seven devices, including the computer. See [Daisy Chain](#) for further information.

## USB 3.1 Gen 2 connection



**Note on USB connections:** Your computer can only recognize one RAID array when using a USB connection. Use Thunderbolt 3 if you intend to create more than one RAID array.

### PC or Mac with a USB-C port

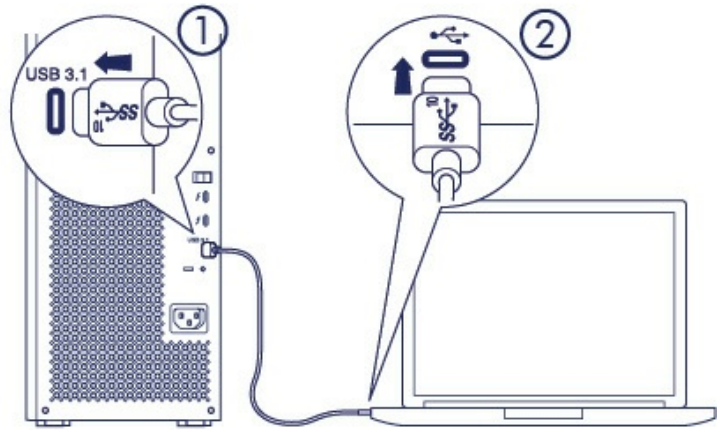
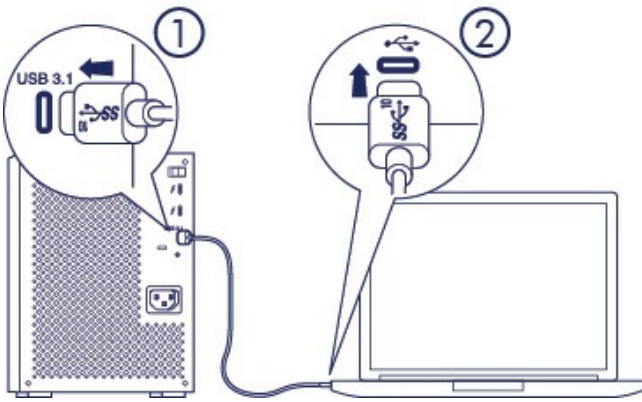

Connect the included USB-C cable to:

1. LaCie 6big/LaCie 12big. Make certain to use the correct port with the text .
2. PC or Mac. Connect to a USB-C port with the USB 3.1 Gen 1 or USB 3.1 Gen 2 icon.



**Note on USB-C connections:** Your computer must support USB 3.1 Gen 2 for transfer rates up to 10Gb/s. Connecting the LaCie 6big/LaCie 12big to a USB 3.1 Gen 1 port gives you speeds up to 5Gb/s.

## PC or Mac with a USB 3.0 or USB 2.0 port (Type A)

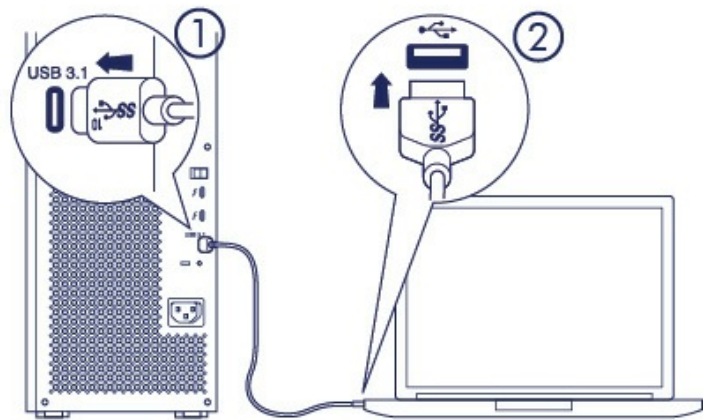
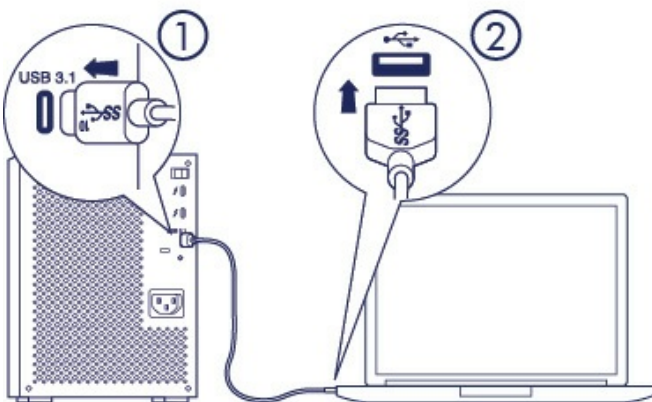

Connect the included USB 3.1 (USB-C) to USB 3.0/USB 2.0 adapter cable (compatible with Type-A ports) to:

1. LaCie 6big/LaCie 12big (USB-C end)
2. PC or Mac (USB Type-A end)



**Note on USB-C connections:** Your computer must support SuperSpeed USB 3.0 for transfer rates up to 5Gb/s. Connecting the LaCie 6big/LaCie 12big to a Hi-Speed USB 2.0 port gives you transfer rates up to 480Mb/s.

## Step 3 - Power connection

Only use the power cable provided with your device. Attaching third-party or other LaCie power cables can damage your LaCie 6big Thunderbolt 3 or LaCie 12big Thunderbolt 3.

Connect the included power cable in the order listed below.

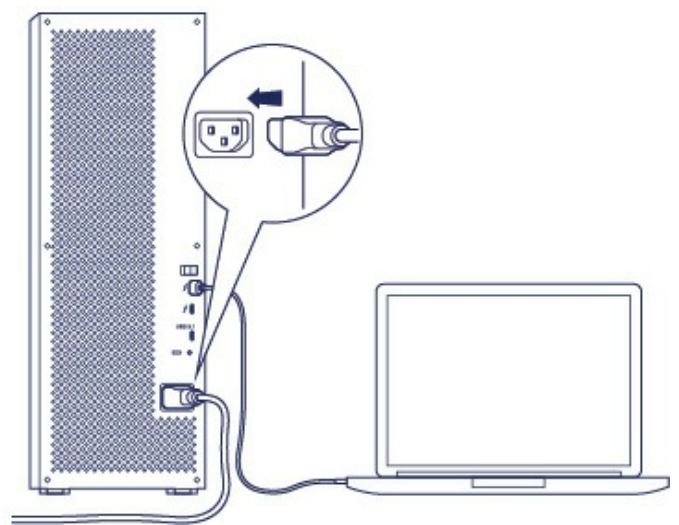
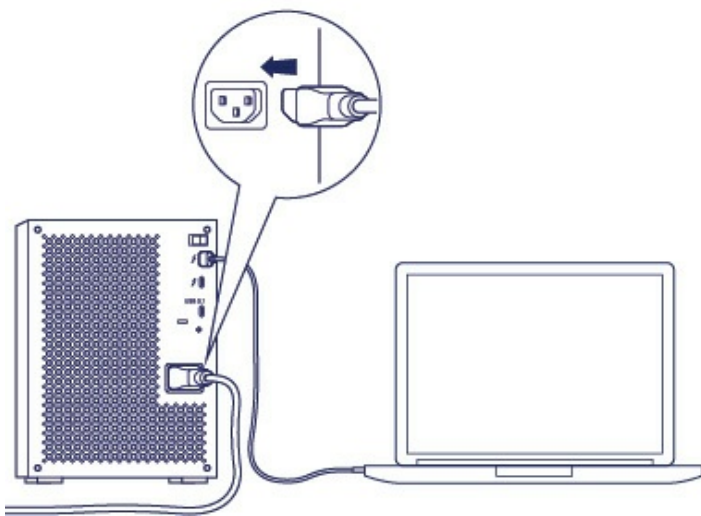

1. The LaCie 6big/LaCie 12big power input.
2. A live power outlet.

## Step 4 - Power switch

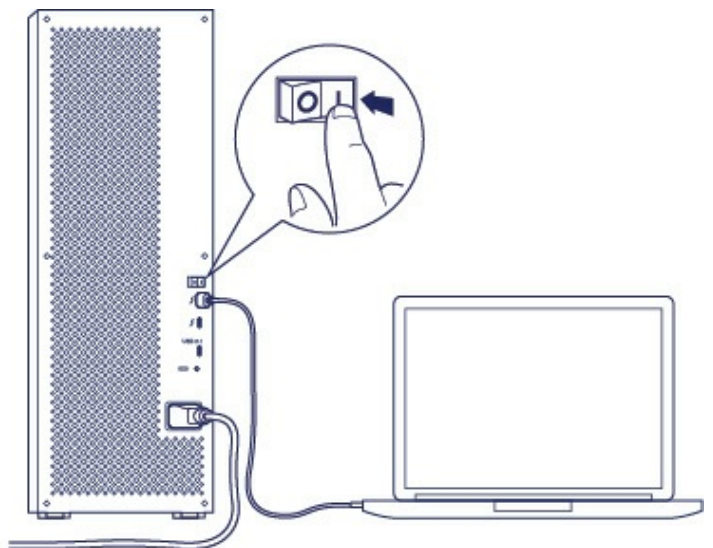
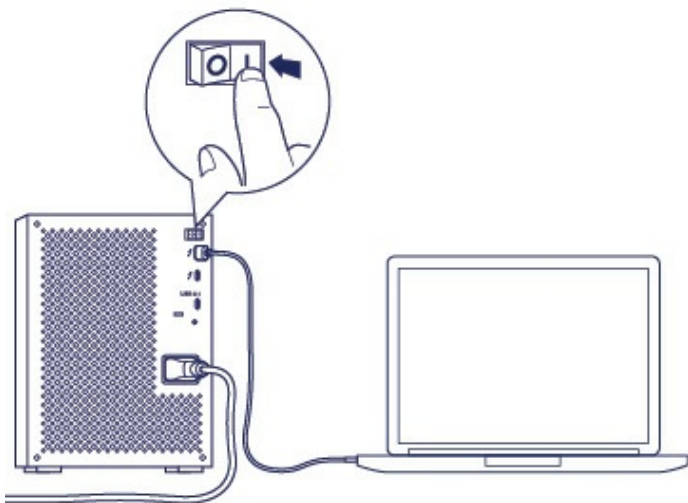

Flip the switch on the back of the device to the “On” position.



**Note:** The LaCie 6big/LaCie 12big must be connected to a computer that supports Thunderbolt 3 or USB 3.1/3.0/2.0 and is powered on. The LaCie 6big/LaCie 12big will not power on if the computer is off.

## Format LaCie 6big/12big storage

Your LaCie 6big/LaCie 12big is shipped as unformatted. When first connecting the device to a computer, you are prompted to format the default RAID 5 array. Before formatting the array, review the chapter on [RAID](#) to learn which RAID level is best for your working environment. If you want to change the RAID level or create multiple arrays, see the instructions in the [LaCie RAID Manager user manual](#).

To format the array, follow your operating system’s prompts and use one of the formats listed below.

- Mac: Mac OS Extended (Journaled), also known as HFS+
- Windows: NTFS

For more information about hard drive formats and instructions for each operating system, see [Formatting and Partitioning](#).

# Operation

- ! **Caution:** Do not operate LaCie 6big Thunderbolt 3 and LaCie 12big Thunderbolt 3 until the ambient temperature is within the specified temperature range (see [System Overview](#)). If the hard drives have been recently installed, make sure they have time to acclimatize to the ambient temperature before operating them.

LaCie 6big/LaCie 12big is ready to be powered on when:

- It is connected to a computer that supports Thunderbolt 3 or USB.
- It is plugged into a live power outlet.

To prepare the device, confirm the following:

- All the hard drive trays are firmly seated in their bays.
- The power cable is connected to a powered outlet.
- If the LaCie 6big/LaCie 12big is in idle mode or powered off, apply a short push to the LED power button. See the explanations below regarding a short push and a long push.

The LEDs blink blue while the disks spin up. You can start using the storage once all LEDs are solid blue.

## Powering off the LaCie 6big/LaCie 12big hard drives: idle mode

Place your device in idle mode if the computer will remain connected to the enclosure but you do not intend to access the storage. Before following the steps below, make certain that the LaCie 6big/LaCie 12big is not in use and that there are no active transfers.

1. Eject the LaCie 6big/LaCie 12big volumes from your computer.
2. Apply a short push to the power button. See the explanation below regarding a short push and a long push.

The status LED blinks slowly while the hard drive LEDs turn off.

You can daisy chain Thunderbolt 3 devices when the LaCie 6big/LaCie 12big is in idle mode.

## Powering off the LaCie 6big/LaCie 12big enclosure

Power off your device if you intend to disconnect it from your computer. Make certain that the LaCie 6big/LaCie 12big is not in use and that there are no active transfers.

1. Eject the LaCie 6big/LaCie 12big volumes from your computer.

2. Apply a short push to the power button. See the explanation below regarding a short push and a long push. The status LED blinks slowly while the hard drive LEDs turn off.

It is now safe to unplug the power and Thunderbolt or USB cables from the device.

**i** **Important info:** LaCie does not recommend applying a long push to power off the enclosure. See the note below for long push.

## Short push

**i** **Important info:** Always eject the LaCie 6big/LaCie 12big volumes from your computer before applying a short push.

A short push is a manual depression on the LED power button that lasts no longer than one second. When the product is operating, a short push spins down the hard drives within the enclosure. The Thunderbolt 3 ports remain active and are available for daisy chaining. This is called idle mode. For example, a display that is daisy chained with the LaCie 6big/LaCie 12big will remain available to the computer following a short push.

## Short push and RAID synchronization/initialization

Applying a short push during RAID synchronization or initialization spins down the hard drives. The RAID synchronization/initialization continues the next time you spin the hard drives up via a short push.

## Long push

A long push is a manual depression on the button that lasts more than four seconds. When the product is operating, a long push will cut the power to the LaCie 6big/LaCie 12big, forcing it to shut down immediately. A long push is not recommended for general use as it may result in data loss.

## Removing the Thunderbolt cable during operation

Removing the cable during operation can have serious consequences, such as lost data. If the cable is removed while the system is synchronizing or initializing the RAID, the synchronization/initialization continues but connection to the computer and your data is lost.

## Quiet operation and heat management

To reduce noise during operation, the LaCie 6big/LaCie 12big uses a Noctua® cooling fan to pull heat away

from the internal components. In addition to being exceptionally quiet, the Noctua cooling fan is temperature controlled, which guarantees optimal heat management by adjusting the rotational speed for the environment. Additionally, the LaCie 6big/LaCie 12big enclosure's metal casing dissipates heat from the hard drives, keeping them safe and prolonging their life. Since LaCie's unique design draws heat away from the internal hard drives, the external casing is warm to the touch after extended use.

**i** **Important info:** The wide exhaust chamber on the rear of LaCie 6big/LaCie 12big allows for enhanced airflow. Make sure that it is not obstructed and that there is a natural airflow across the casing.

## Position and stacking

Always make certain to place LaCie 6big/LaCie 12big on a flat, even surface designed to support the heat output and airflow of a professional hard disk enclosure. For proper heat dissipation, LaCie 6big/LaCie 12big is designed to stand on its rubber feet, situated on the bottom of the enclosure. **DO NOT** place the enclosure on its side when it is powered on.

**DO NOT** stack multiple enclosures on top of each other. Stacking two or more enclosures poses a severe risk that the devices will fall. Also, **DO NOT** stack other hard drives, enclosures or equipment on top of the LaCie 6big Thunderbolt 3 and LaCie 12big Thunderbolt 3.

The warranty for your LaCie 6big Thunderbolt 3 and LaCie 12big Thunderbolt 3 is voided if you:

- Stack LaCie 6big Thunderbolt 3 and/or LaCie 12big Thunderbolt 3 enclosures.
- Stack other hard drives, enclosures or equipment on top of the LaCie 6big Thunderbolt 3 and/or LaCie 12big Thunderbolt 3 enclosures.

# Daisy Chain and Power Delivery

Use the two Thunderbolt 3 ports on the LaCie 6big/LaCie 12big for:

- Direct connection to a computer that is compatible with Thunderbolt 3 technology.
- Daisy chaining with devices and displays that are compatible with Thunderbolt 3 technology.
- Charging the batteries of compatible devices.

## Daisy chain Thunderbolt 3 devices

Thunderbolt 3 is an update of Thunderbolt 2 technology. While Thunderbolt 2 technology continues to provide impressive transfer rates up to 20Gb/s bi-directional, Thunderbolt 3 offers improved performance with a potential up to 40Gb/s bi-directional. Thunderbolt 3 technology also gives you greater flexibility when using video and data, assigning greater throughput to the stream that carries the heavier load. You must have a computer that supports Thunderbolt 3 to take advantage of the updates in performance and the intelligent sharing of bandwidth.

Similar to Thunderbolt 2 technology, a single Thunderbolt 3 daisy chain can have up to seven devices, including the computer. For example, you can daisy chain five LaCie 6big/LaCie 12big Thunderbolt 3 enclosures on the same line with a display.

## How to daisy chain

Connect the cable to one of the interface ports on the back of LaCie 6big/LaCie 12big and to your computer. The additional port on LaCie 6big/LaCie 12big can be used to daisy chain compatible Thunderbolt 3 peripherals, such as hard drives and monitors. If you have another Thunderbolt 3 storage device, make certain to connect it to the daisy chain before adding compatible displays or USB 3.1 (USB-C) devices. See below for an example of the order of devices in a Thunderbolt 3 daisy chain.

1. Computer with a Thunderbolt 3 port
2. LaCie 12big Thunderbolt 3 (Thunderbolt 3 ports)
3. LaCie 6big Thunderbolt 3 (Thunderbolt 3 ports)
4. LaCie Bolt 3 (Thunderbolt 3 ports)
5. LaCie Porsche Desktop (USB 3.1 (USB-C) port)

USB 3.1 (USB-C) devices can terminate a Thunderbolt 3 daisy chain and should always be the last device.



**Note on the USB 3.1 (USB-C) port:** USB 3.1 does not support daisy chaining devices. Therefore, a USB 3.1 (USB-C) port on your computer cannot be used to daisy chain devices.



**i** **Important cable info:** When connecting your enclosure to a computer or compatible devices, use cables specifically constructed to support Thunderbolt 3.

**i** **Important info:** To reach Thunderbolt 3 transfer rates up to 40Gb/s bi-directional, LaCie 6big/LaCie 12big Thunderbolt 3 must be connected to a computer that supports Thunderbolt 3 technology.

## Daisy chain: idle mode

You can daisy chain Thunderbolt 3 devices even when the LaCie 6big/LaCie 12big hard drives are spun down. Apply a short push on the LED power button (see [Operation](#)). The status LED blinks slowly, indicating that the LaCie 6big/LaCie 12big is in idle mode.

## Power delivery

Each Thunderbolt 3 port on LaCie 6big/LaCie 12big outputs up to 15W. You can connect compatible devices that support charging via USB-C to the Thunderbolt 3 ports. LaCie 6big/LaCie 12big must receive power via its power cable to deliver power to compatible devices.

**i** **Important info:** LaCie is not responsible for devices that experience harm, damage or malfunction when connected to LaCie 6big/LaCie 12big.

# Software

The storage for LaCie 6big Thunderbolt 3 and LaCie 12big Thunderbolt 3 is managed by LaCie RAID Manager. Use LaCie RAID Manager to:

- Configure RAID
- Check the health of the storage
- Set up storage alerts
- Troubleshoot the hard drives

See the [LaCie RAID Manager user manual](#) for instructions how to manage the LaCie 6big/LaCie 12big storage.

# RAID

The information below provides a basic guide to the RAID modes available to LaCie 6big/12big Thunderbolt 3. Performance and protection differ based upon RAID level and the number of hard drives in a RAID array. For instructions how to configure a RAID array, see the [LaCie RAID Manager user manual](#).

The level of RAID is contingent upon the amount of disks. For example, an array with four disks supports all standard RAID levels except RAID 1, which is not compatible with arrays greater than two disks. When making comparisons in an array with four disks, RAID 0 appears to be the optimal choice since it offers 100% storage capacity and the best performance. However, RAID 0's major weakness is a lack of data protection in case of hard drive failure. Further, its performance is not much greater than RAID 5, which includes data protection in case one hard drive should fail. RAID 6 and, in unique cases, nested RAID levels, can provide data protection in the event that two or more hard drives fail.

Review the summaries for each RAID level before selecting your configuration for the LaCie 6big/LaCie 12big storage.

RAID mode	Type	Minimum hard drives
RAID 0	Standard	2
RAID 1	Standard	2
RAID 5	Standard	3
RAID 6	Standard	4
RAID 10	Nested	4
RAID 50	Nested	6
RAID 60	Nested	8

## Standard RAID levels

### RAID 0

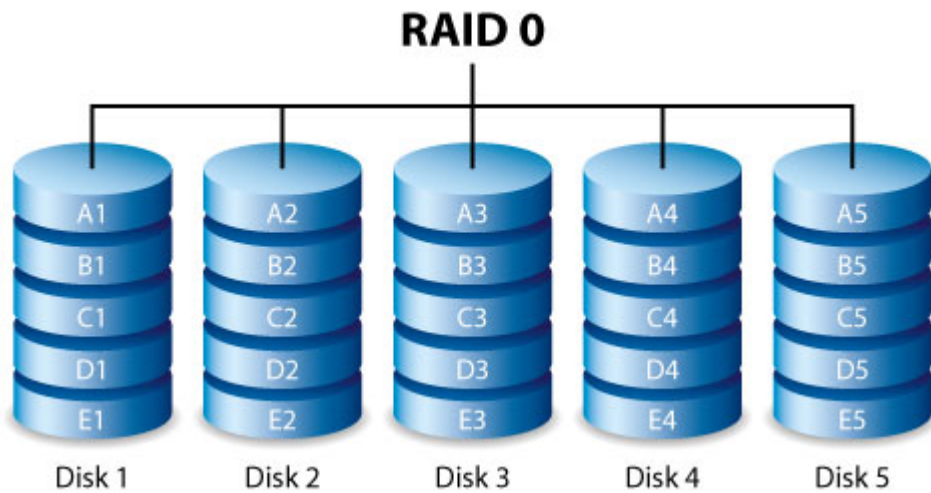

RAID 0 is the fastest RAID mode since it writes data across all of the array's hard drives. Further, the capacities of each disk are added together for optimal data storage. However, RAID 0 lacks a very important feature: data protection. If one hard drive fails, all data is lost. A recommended option is RAID 5, which offers:

- Performance that can approach RAID 0.
- Approximately 75% of the storage capacity of all the hard drives in the RAID configuration.
- Data protection in case a single hard drive fails.

## RAID 1

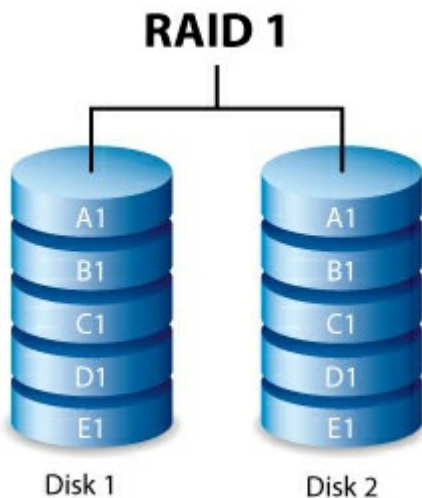

RAID 1 provides enhanced data security since all data is written to each disk in the array. If a single disk fails, data remains available on the other disk in the array. However, due to the time it takes to write data multiple times, performance is reduced. Additionally, RAID 1 reduces disk capacity by 50% since each bit of data is stored on both disks in the array.

## RAID 5

## RAID 5

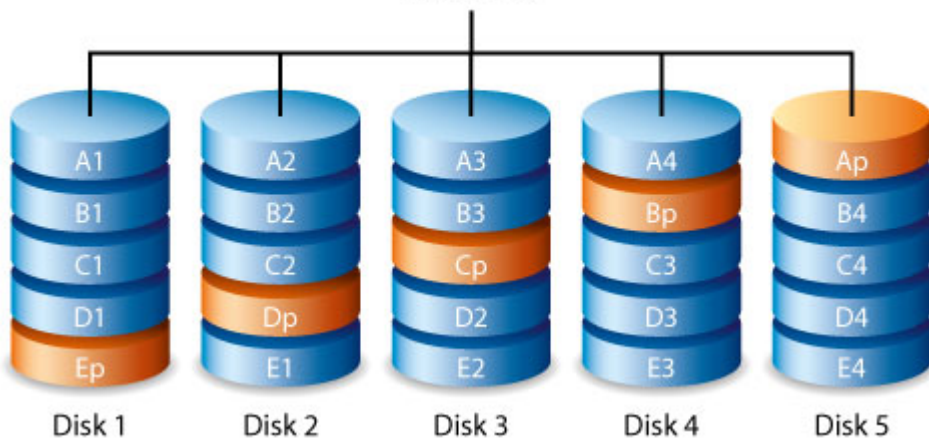

RAID 5 writes data across all hard drives in the array and a parity block for each data block. If one physical hard drive fails, the data from the failed hard drive can be rebuilt onto a replacement hard drive. While the files stored on a RAID 5 array remain intact should one hard drive fail, data can be lost if a second hard drive fails before the RAID is rebuilt with the replacement hard drive.

A minimum of three hard drives is required to create a RAID 5 array.

RAID 5 offers performance that can approach RAID 0. RAID 5's strong advantage over RAID 0 is data protection. Additionally, you still have approximately 75% of the storage capacity of a RAID 0 array (based upon total available hard drives and storage capacities). The equation for determining the storage is:

The size of the hard drive with the smallest capacity in the array) \* (Total hard drives-1)

Example 1: An array is assigned five 3TB hard drives for a total of 15TB. The equation is:

$$3\text{TB} * 4 = 12\text{TB}.$$

Example 2: An array is assigned Three 2TB hard drives and one 3TB hard drive for a total of 9TB. The equation is:

$$2\text{TB} * 3 = 6\text{TB}.$$

## RAID 6

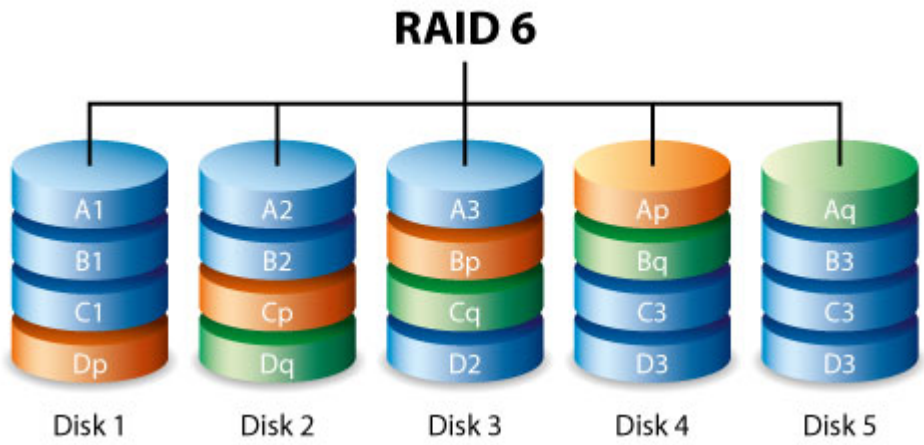

RAID 6 writes data across all disks in the array and two parity blocks for each data block. If one physical disk fails, the data can be rebuilt onto a replacement disk. With two parity blocks per data block, RAID 6 supports up to two disk failures with no data loss. RAID 6 synchronizing from a failed disk is slower than RAID 5 due to the use of double parity. However, it is far less critical due to its double-disk security.

A minimum of four disks is required to create a RAID 6 array. RAID 6 offers very good data protection with a slight loss of performance compared to RAID 5.

## Nested RAID levels

### RAID 10

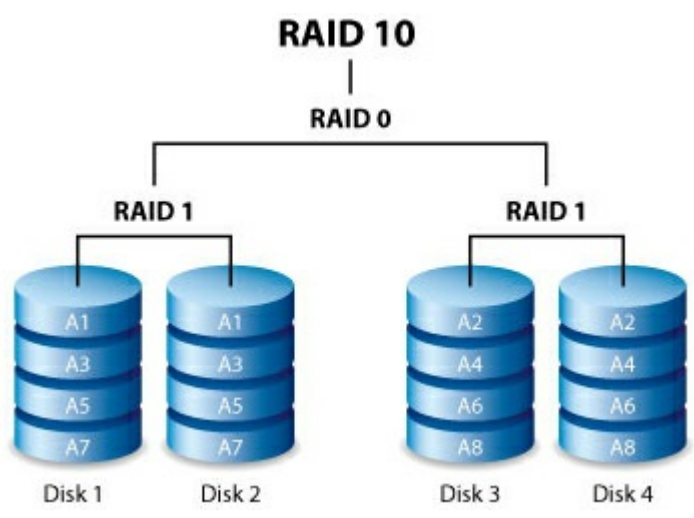

RAID 10 combines the protection of RAID 1 with the performance of RAID 0. Using four disks as an example, RAID 10 creates two RAID 1 segments, and then combines them into a RAID 0 stripe. Such configurations offer exceptional data protection, allowing for two disks to fail across two RAID 1 segments. Additionally, RAID 10 writes data at the file level and, due to the RAID 0 stripe, gives users higher performance when managing greater amounts of smaller files. This means a more generous input output per second for data, referred to as IOPS.

RAID 10 is a great choice for database managers that need to read and write a multitude of smaller files across the array's disks. The impressive IOPS and data protection offered by RAID 10 gives database managers impressive reliability both in keeping files safe and rapid access.

## RAID 50

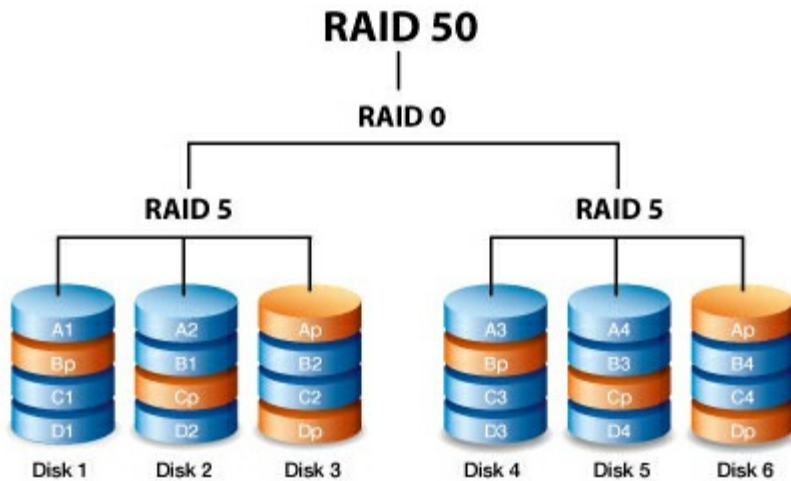

RAID 50 combines RAID 0 striping with RAID 5 parity. Due to the speed of RAID 0 striping, RAID 50 improves upon RAID 5 performance, especially during writes. It also offers more protection than a single RAID level. Use RAID 50 when you need improved fault tolerance, high capacity and impressive write speeds.

A minimum of six hard drives is required for a RAID 50 array. A RAID 50 array with a high number of hard drives increases the time to initialize and rebuild data due to the large storage capacity.

## RAID 60

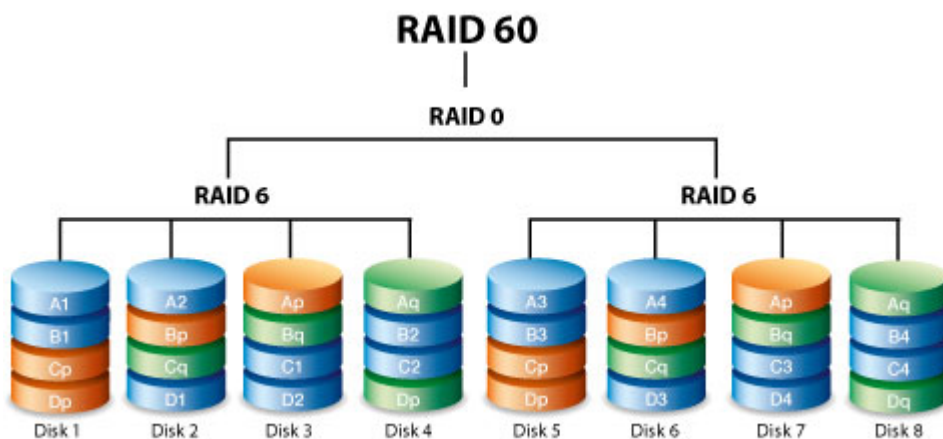

RAID 60 combines RAID 0 striping with RAID 6 double parity. Due to the speed of RAID 0 striping, RAID 60

improves upon RAID 6 performance. It also offers more protection than a single RAID level. Use RAID 60 when you need improved fault tolerance, high capacity and impressive write speeds.

A minimum of eight hard drives is required for a RAID 60 array. Since a RAID 60 array has a high number of hard drives, the time to initialize and rebuild data is longer than a single RAID level.

## RAID+Spare

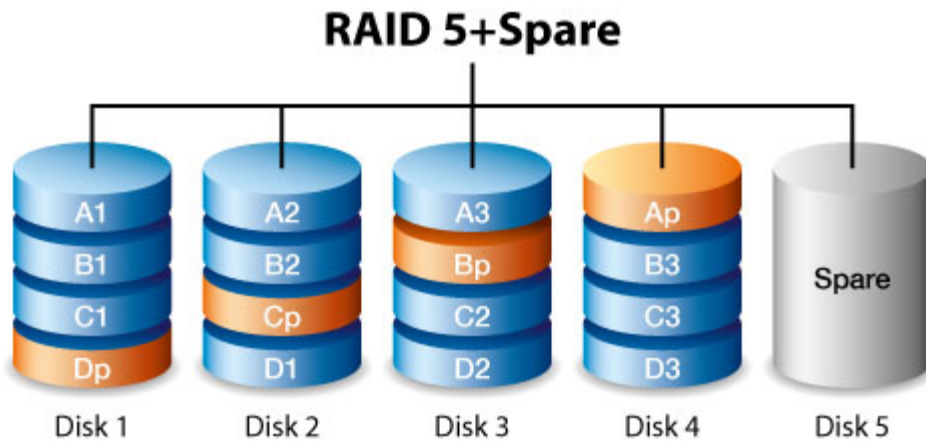

A RAID+Spare array gives you a “hot-spare” that is ready to synchronize data immediately should a hard drive fail. If a hard drive in the array fails, the data starts to synchronize with the spare. The advantage for a RAID array with a spare is the immediacy of the replacement hard drive. However, the spare cannot be used as storage during standard operation since its sole task is to take over should a hard drive fail.

You can replace the failed hard drive immediately and, once synchronization is complete, assign it as a new spare.

## Drive failures and synchronizing a spare hard drive

For RAID+Spare arrays, data remains intact when the minimum number of redundant hard drives fail. However, if an additional hard drive fails before or during data synchronization with a spare hard drive, the data in the array is lost. See the examples below.

- **RAIDs 1 and 5:** one drive has failed and the array immediately begins to synchronize with the spare hard drive. If a second hard drive in the RAID 5 array fails before synchronization is complete, all data in the array is lost.
- **RAID 6:** two hard drives have failed and the array immediately begins to synchronize the first failed hard drive with the spare. If a third hard drive in the RAID 5 array fails before synchronization is complete, all data in the array is lost.
- **Nested RAID:** nested RAID levels have greater fault tolerances depending upon which of the nested RAID arrays have hard drives that fail.
  - **RAIDs 10 and 50:** each of the nested arrays can lose one hard drive. If one of the two nested arrays loses two hard drives before or during the synchronization, data is lost.



- **RAID 60:** each of the nested arrays can lose two hard drives. If one of the two nested arrays loses three hard drives before or during the synchronization, data is lost.

# Hard Drive Maintenance

## Precautions

- “Hot-swapping” means that you can remove and replace hard drives while the enclosure is powered on. LaCie 6big Thunderbolt 3 and LaCie 12big Thunderbolt 3 feature hot-swappable hard drives.
- During operation, the hard drives should remain in their slots for optimal air flow. Airflow and fan performance are regulated by temperature.
- Observe all conventional ESD precautions when handling hard drives.

## Replacing a hard drive

Replace a hard drive if:

- You want to expand the available storage space by adding a hard drive with a larger capacity.
- The hard drive has failed.

If a failed hard drive is under warranty, make certain to contact [LaCie support](#) to receive a replacement disk.

When adding new hard drives or replacing hard drives that are not under warranty, consider using Seagate Enterprise HDD that are optimized for use with your LaCie 6big Thunderbolt 3 and LaCie 12big Thunderbolt 3. For further information about compatible hard drives, visit [LaCie support](#).

Since LaCie 6big/LaCie 12big supports hot swapping hard drives, it is not necessary to power down the device to replace a single hard drive.

**i** **Important info:** Replace a faulty hard drive with a hard drive of equal or greater capacity.

**i** **Important info:** When handling hard drives, make sure that they are placed and stored on a cushioned surface.

1. Locate the hard drive you want to replace and place your index finger on the small hole on the right side of its disk tray.

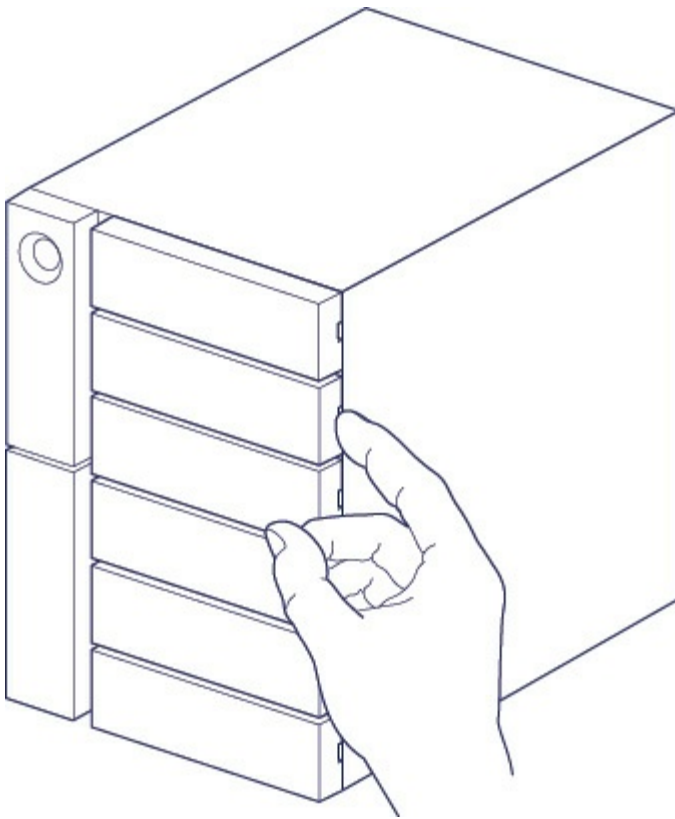

2. Gently pull your index finger away from the enclosure and maintain a firm grip as it unlocks the hard drive from the SATA connector. Once it is loose, hold the hard drive with both hands as you remove it from the slot.

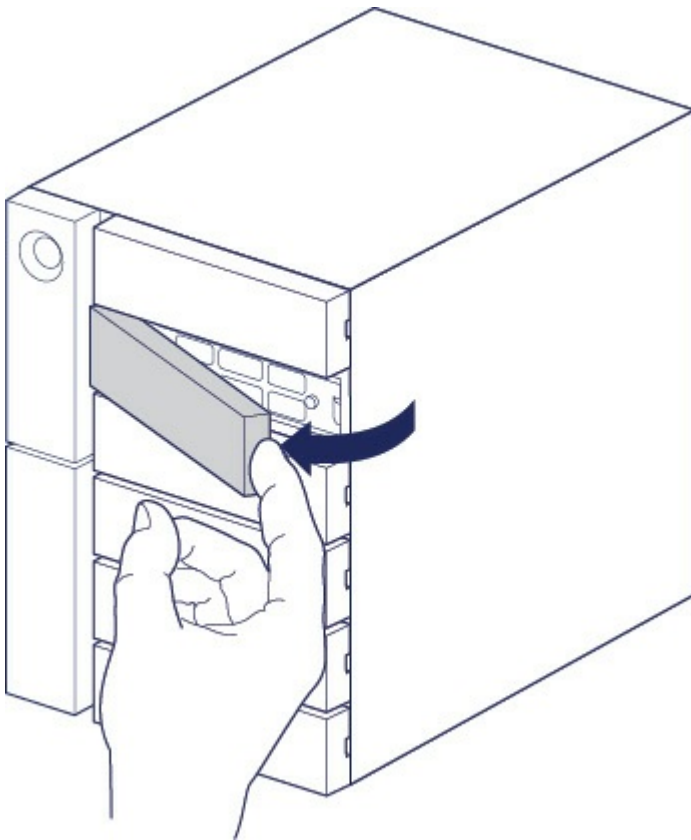

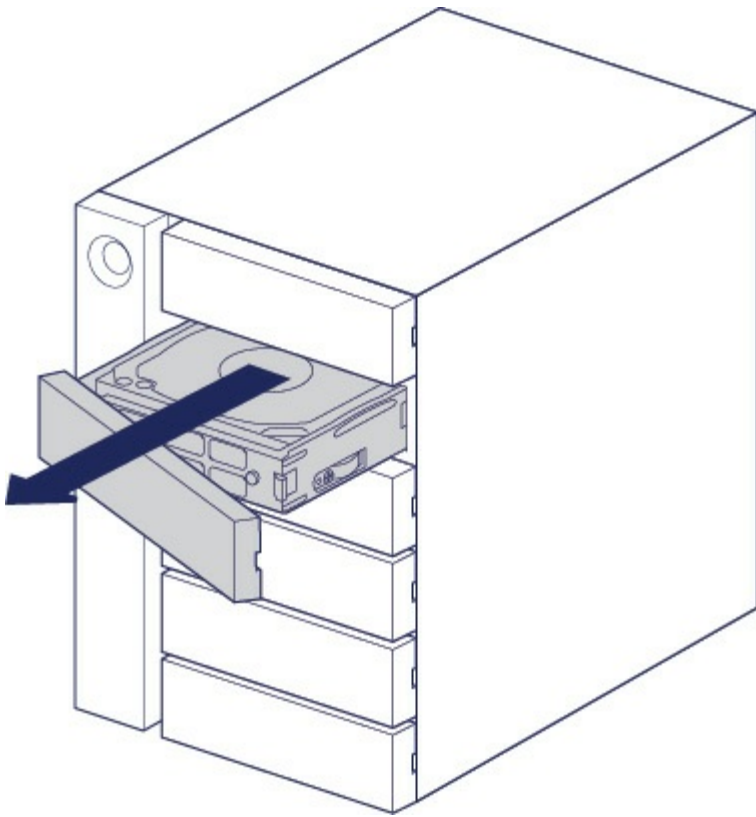

3. If you are replacing a failed hard drive with a full disk tray, skip to Step 4. Continue here if you are replacing the hard drive using the same disk tray.
- Using a Phillips head screwdriver, carefully unfasten all four screws from their four slots.

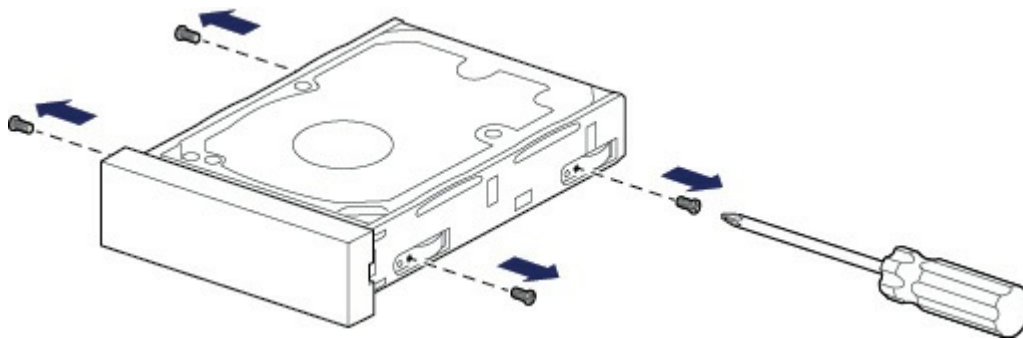

- Gently slide the disk out of the tray.

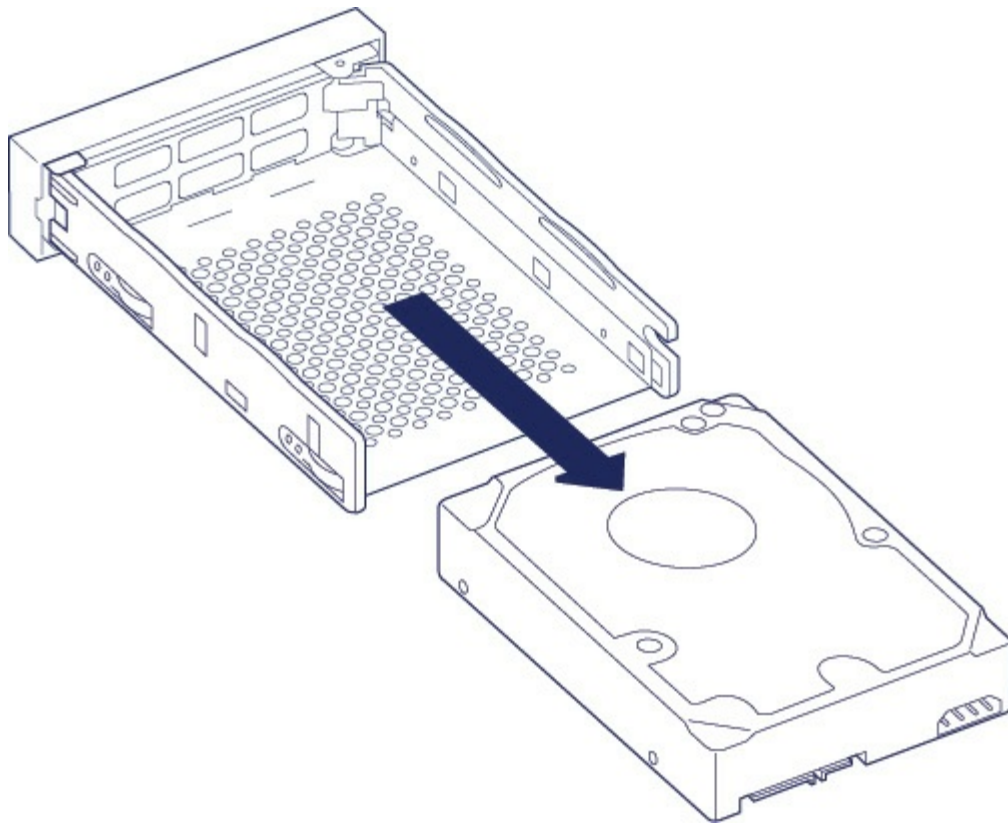

- Place the empty disk tray onto a flat work area with the handle on the bottom left.
- Many disks have a label on one side and the printed circuit board on the opposite side. With its label side facing up, gently place the hard disk within the disk tray. Keep the SATA connector facing to the right. The four screw slots should align with the disk's four screw holes.

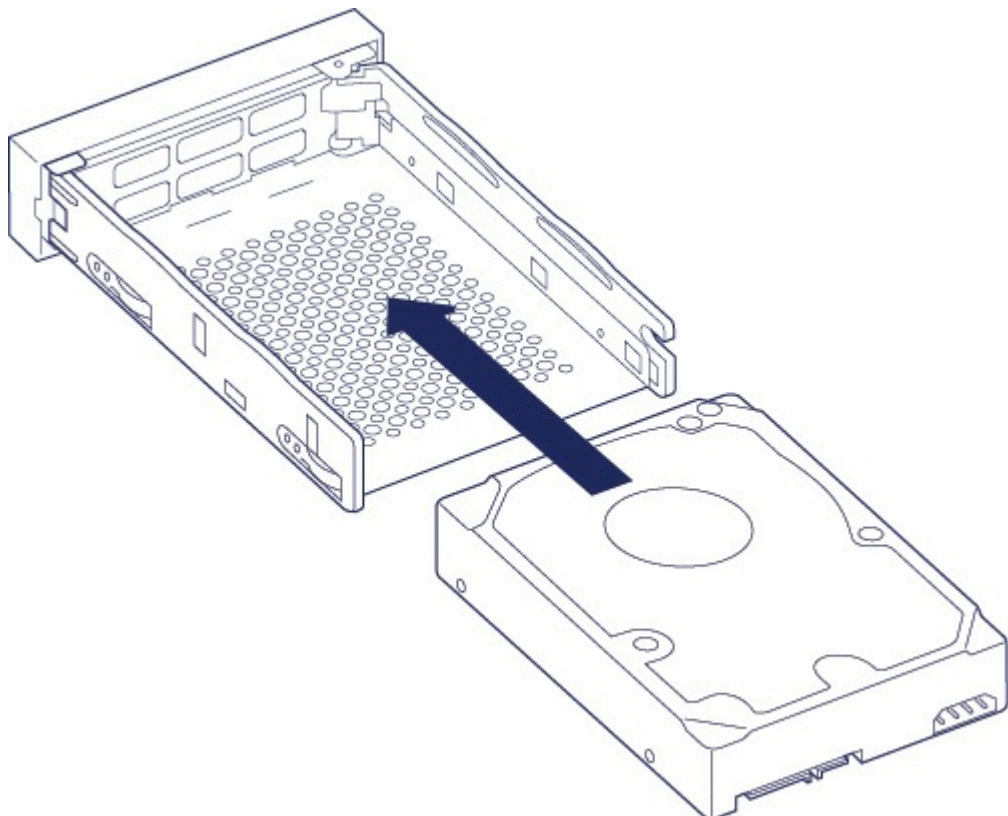

- Using a Phillips head screwdriver, carefully fasten all four screws into their four slots. Do not force the screws into the slots. Forcing the screws too tight into the slots can make it difficult to remove them

later and strip the screws' teeth.

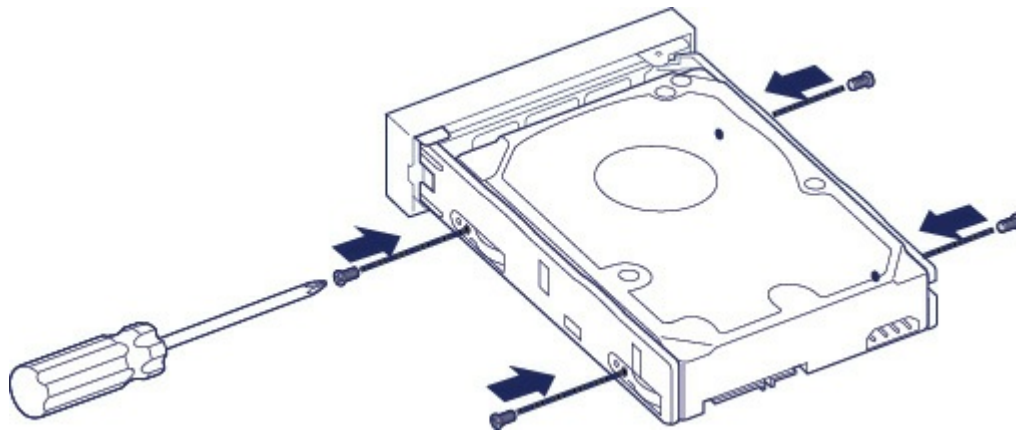

4. Carefully insert the full disk tray into the empty disk slot. Gently push the disk tray handle until you feel it snap into place.

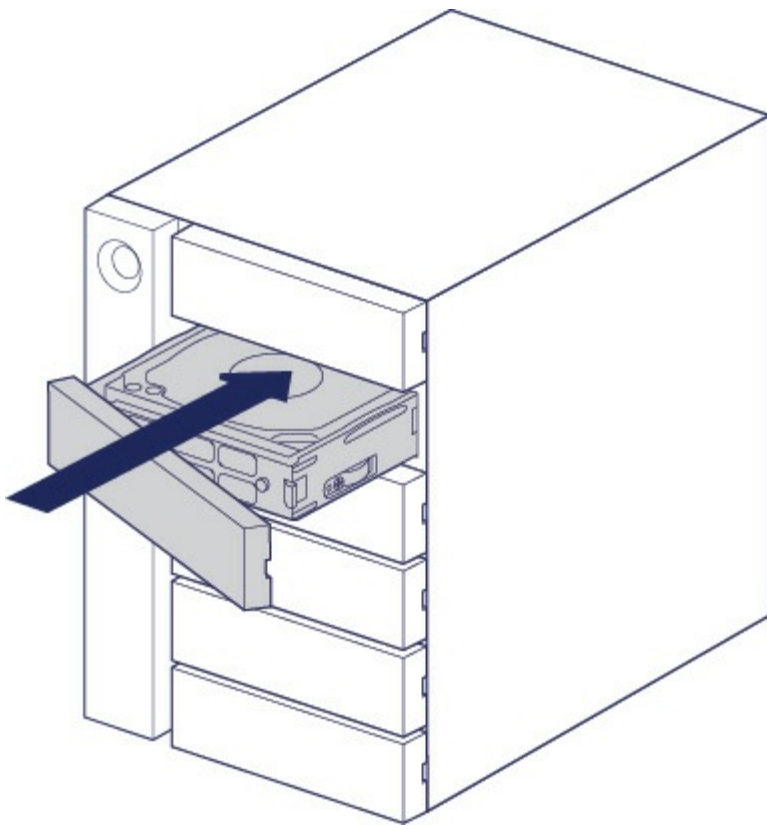

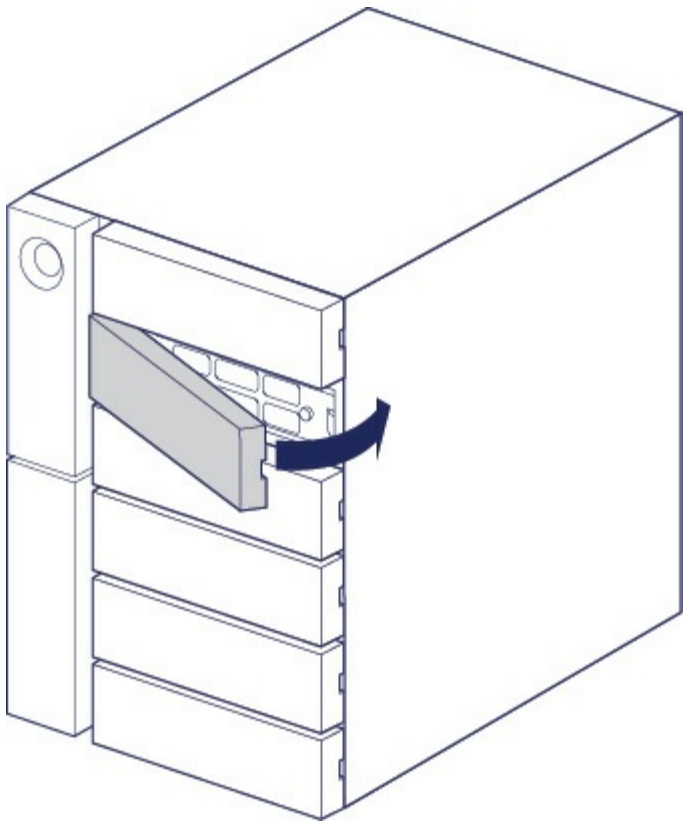

See the [LaCie RAID Manager user manual](#) for instructions how to manage the LaCie 6big/LaCie 12big storage.

When replacing hard drives that are members of an active RAID array, the hard drive LEDs blink red and blue indicating that the RAID is synchronizing data. You can continue to use the LaCie 6big/LaCie 12big storage but performance is reduced until the synchronization is complete.

## LaCie 6big/LaCie 12big enclosure: non-serviceable components

The components inside the chassis are **NOT** hot-swappable and are **NOT** serviceable at any location outside of LaCie-approved service centers. **Removing the cover voids your product's warranty.** Additionally, removing, replacing or changing any part in the enclosure or, performing any action that involves the components in the enclosure, voids the product's warranty. If you are experiencing hardware errors or failure, contact [LaCie support](#) for assistance.

# Formatting and Partitioning

Your LaCie 6big/LaCie 12big is shipped as unformatted. When first connecting the device to a computer, you are prompted to format the default RAID 5 array. Before formatting the array, review the chapter on RAID to learn which RAID level is best for your working environment. If you want to change the RAID level or create multiple arrays, see the instructions in the [LaCie RAID Manager user manual](#).

When formatting the array, consider the operating system on your computer. If you intend to use LaCie 6big/LaCie 12big with Mac computers, format the array as Mac OS Extended (HFS+). If you use the device exclusively on Windows, format the array as NTFS. See the details below for more information about system formats.

## About file system formats

**NTFS:** since it is the native file system for Windows, volumes created in NTFS are read and write with computers running Windows. Mac OS can read NTFS volumes but cannot natively write to them.

**Mac OS Extended (HFS+):** the native hard drive file system for Mac. Windows cannot natively read or write to HFS+ (journaled) hard drives.

**exFAT:** generally compatible with Mac and Windows. exFAT is not a journaled file system which means it can be more susceptible to data corruption when errors occur or the drive is not disconnected properly from the computer.

**FAT32:** compatible with Mac and Windows. However, FAT32 is a legacy file system designed for low capacity hard drives and it is not recommended for modern hard drives or operating systems. A FAT32 partition can reach up to 32GB when formatted on a Windows PC.

### How to choose the file system format

---

#### Use NTFS if:

...the storage device is connected to Windows PCs.

---

#### Use HFS+ if:

...the storage device is connected to Macs.

---

#### You can use exFAT if:

...the storage device is shared between Mac and Windows computers.

---

#### Use FAT32 if:

...the storage device is connected to older Windows and Mac computers. FAT32 is not recommended for modern operating systems and computers.

---

## Formatting instructions

The steps below help you format and partition a storage device.





**Caution:** Formatting erases everything on the storage device. LaCie highly recommends that you back up all data on your storage device before performing the steps below. LaCie is not responsible for any data lost due to formatting, partitioning or using a LaCie storage device.



**Note:** Refer to your operating system's documentation for more information on formatting and partitioning storage devices.

## Windows

1. Make sure the storage device is connected to and mounted on the computer.
2. Go to Search and then type **diskmgmt.msc**. In the search results, double click **Disk Management**.
3. From the list of storage devices in the middle of the Disk Management window, locate your LaCie device.
4. The partition must be available to format. If it is currently formatted, right click on the partition and then choose **Delete**.
5. To create a new partition, right click on the volume and select **New Simple Volume**. Follow the on-screen instructions when the New Simple Volume Wizard appears.

## Mac

1. Make sure the storage device is connected to and mounted on the computer.
2. Select **Go > Utilities** in the Finder menu bar.
3. In the Utilities folder, double-click **Disk Utility**.  All connected storage devices, partitions or disk images are displayed in the left column.
4. Select the LaCie hard drive in the left column.
5. Click the **Erase** tab.
6. Choose a format from the drop-down window.
7. Enter a name for the volume.
8. Click **Erase** and confirm your selection in the pop-up window.

# Frequently Asked Questions

For help setting up and using your LaCie hard drive, review the frequently asked questions below. For additional support resources, go to [LaCie customer support](#).

## All users

### Problem: My file transfers are too slow.

#### Thunderbolt 3/USB

**Q:** Are both ends of the cable firmly attached?

**A:** Review troubleshooting tips for cable connections below:

- Check both ends of the cable and make sure they are fully seated in their respective ports.
- Try safely ejecting LaCie 6big/LaCie 12big from your computer and then disconnect the cable. Wait 10 seconds and then reconnect LaCie 6big/LaCie 12big to the computer.

**Q:** Are there other Thunderbolt 3 or USB devices connected to the same port or hub?

**A:** Disconnect other devices and see if the drive's performance improves.

#### Thunderbolt 3

**Q:** Is the device connected to a Thunderbolt 3 USB-C port on your computer or hub?

**A:** Connect LaCie 6big/LaCie 12big to a USB-C port on your computer that supports Thunderbolt 3 devices. The lightning bolt icon that represents Thunderbolt 3 support should appear next to the USB-C port.

**Q:** Does your computer or operating system support Thunderbolt 3?

**A:** Consult your computer and operating system documentation for Thunderbolt 3 compatibility information.

#### USB

**Q:** Is the device connected to Hi-Speed USB 2.0 on your computer or hub?

**A:** If your hard drive is connected to a USB 2.0 port, the slower performance is normal. LaCie 6big/LaCie 12big USB performance is significantly better when it is connected to a USB 3.1 port or a SuperSpeed USB 3.0 port. Otherwise, LaCie 6big/LaCie 12big operates at slower USB transfer rates.

### Problem: I connected LaCie 6big/LaCie 12big to my computer but it does not power on and I cannot see the device in LaCie RAID Manager.

**Q:** Which cable and port did you use to connect LaCie 6big/LaCie 12big to the computer?

**A:** LaCie 6big/LaCie 12big is shipped with two USB-C cables, one for Thunderbolt 3 connections and one for USB 3.1 connections. Both are clearly marked by logos, a thunderbolt and the number "3" for Thunderbolt 3 connections and the USB 3.1 Gen 2 logo with the number "10" for USB 3.1 connections. Since both cables have USB-C cable ends, make certain to choose the correct cable for the interface you are using to connect LaCie 6big/LaCie 12big to your computer.

Additionally, make certain to connect the Thunderbolt 3 port on LaCie 6big/LaCie 12big to a computer that features a Thunderbolt 3 port. A Thunderbolt 3 port is a USB-C port that has a thunderbolt. Other USB-C ports do not support Thunderbolt 3 connections. If your computer does not have a USB-C port with a thunderbolt, use the USB 3.1 port on LaCie 6big/LaCie 12big. Please note that it is not possible to access the storage when connecting the Thunderbolt 3 port on LaCie 6big/LaCie 12big to a USB-C port on a computer that does not support Thunderbolt 3. While it is possible to connect LaCie 6big/LaCie 12big's USB 3.1 port to a Thunderbolt 3 port on a computer, the benefits offered by Thunderbolt 3 are lost. Such a connection only allows for using a single array at transfer rates up to 10Gb/s rather than Thunderbolt 3's potential of multiple arrays and transfer rates up to 40Gb/s.

If you see the storage using the USB connection but the Thunderbolt connection does not appear to work, confirm that LaCie RAID Manager is installed on your computer. The installer for LaCie RAID Manager includes an important driver that allows the computer to recognize the storage with Thunderbolt connections. The installer can be downloaded at [LaCie RAID Manager](#).

## **Problem: I want to change the RAID level.**

**Q:** How do I change the RAID level?

**A:** You can manage the storage for LaCie 6big/LaCie 12big using LaCie RAID Manager. To download the installer, go to [LaCie RAID Manager](#). For instructions how to use the application, see the [LaCie RAID Manager user manual](#).

## **Problem: I disconnected my computer from the LaCie 6big/12big during RAID synchronization or initialization.**

**Q:** Can I disconnect my computer during RAID synchronization or initialization?

**A:** Yes. Synchronization and initialization continue uninterrupted when the computer disconnects from LaCie 6big/LaCie 12big. Similarly, LaCie 6big/LaCie 12big can be placed into low power mode or powered off during synchronization and initialization. Provided the same hard drives are in the enclosure, the operation continues once the device is powered on. For more information, see [Operation](#).

## **Problem: I have a USB-C hard drive that I want to add to the Thunderbolt 3 daisy chain.**

**Q:** Can I attach my USB-C hard drive to a Thunderbolt 3 daisy chain?

**A:** Yes. Make certain to add the USB-C hard drive to the end of a Thunderbolt 3 daisy chain since USB devices do not include a second port to continue the chain. Please note that USB-C devices do not become

Thunderbolt 3 devices when added to a Thunderbolt 3 daisy chain. The USB-C device can only provide performance within its potential. For example, a USB 3.1 Gen 1 hard drive added to the end of a Thunderbolt 3 daisy chain can reach up to 5Gb/s while a USB 3.1 Gen 2 hard drive can reach up to 10Gb/s.

## **Problem: I see two or more arrays in LaCie RAID Manager but only one is available on my computer.**

**Q:** Why can't I use all the arrays?

**A:** While LaCie RAID Manager sees all arrays associated with the device, USB connections to LaCie 6big/LaCie 12big allow for one array on your computer. Create a single array from all the hard drives if you connect to LaCie 6big/LaCie 12big via USB. To use multiple arrays, connect to LaCie 6big/LaCie 12big via Thunderbolt 3.

## **Problem: I must password protect and/or encrypt my hard drive.**

**Q:** Can I attach my USB-C hard drive to a Thunderbolt 3 daisy chain?

**A:** Yes, it is possible to protect the hard drive or individual folders and files with a password. There are many third-party solutions for password protection. However, LaCie cannot guarantee them since we do not test third-party applications.

Some versions of Windows have a built-in utility called Bitlocker that can protect hard drives with a password. For more information about Bitlocker, consult [Microsoft's support documentation](#).

**Q:** Can I encrypt my hard drive?

**A:** Yes, the hard drive can be encrypted. There are many third-party solutions for encryption. However, LaCie cannot guarantee them since we do not test third-party applications.

Some versions of Windows have a built-in utility called Bitlocker that can encrypt hard drives. For more information about Bitlocker, consult [Microsoft's support documentation](#)

## **Problem: I'm receiving file transfer error messages.**

**Q:** Did you get an "Error -50" message while copying to a FAT32 volume?

**A:** When copying files or folders from a computer to a FAT32 volume, certain characters in the names cannot be copied. These characters include, but are not limited to: ? < > / \ :

Check your files and folders to ensure that these characters are not in the names.

If this is a recurring problem or you cannot find files with incompatible characters, consider reformatting the drive to NTFS (Windows users) or HFS+ (Mac users). See [Formatting and Partitioning](#).

# Mac

## Problem: The drive icon does not appear on my desktop.

**Q:** Is your Finder configured to hide hard drives on the desktop?

**A:** Go to Finder and then check **Preferences > General tab > Show these items on the desktop**. Confirm that **Hard Disks** is selected.

**Q:** Is your drive mounting in the operating system?

**A:** Open Disk Utility at **Go > Utilities > Disk Utility**. If the drive is listed in the left-hand column, check your Finder preferences to see why it is not displayed on the desktop (review the question above).

**Q:** Does your computer's configuration meet the minimum system requirements for use with this drive?

**A:** Refer to the product packaging for the list of supported operating systems.

**Q:** Did you follow the correct installation steps for your operating system?

**A:** Review the installation steps in Getting Connected.

## Windows

### Problem: The drive icon doesn't appear in Computer.

**Q:** Is the drive listed in Device Manager?

**A:** All drives appear in at least one place in Device Manager.

Go to Search to type Device Manager and then launch it. Look in the Disk Drives section and, if necessary, click the plus sign to view the full list of devices. If you're uncertain that your drive is listed, safely unplug it and then reconnect it. The entry that changes is your LaCie hard drive.

**Q:** Is your drive listed next to an unusual icon?

**A:** Windows Device Manager usually provides information about failures with peripherals. While the Device Manager can assist with troubleshooting most problems, it may not display the exact cause or provide a precise solution.

An unusual icon next to the hard drive can reveal a problem. For example, instead of the normal icon based on the type of device, it is instead an exclamation point, question mark or an X. Right click this icon and then choose **Properties**. The General tab provides a potential reason why the device is not working as expected.