



LaCie Rugged USB-C User Manual

© 2016 Seagate Technology LLC. All rights reserved. Seagate, Seagate Technology, the Wave logo, and FreeAgent are trademarks or registered trademarks of Seagate Technology LLC, or one of its affiliates. All other trademarks or registered trademarks are the property of their respective owners. When referring to hard drive capacity, one gigabyte, or GB, equals one billion bytes and one terabyte, or TB, equals one thousand billion bytes when referring to hard drive capacity. In addition, some of the listed capacity is used for formatting and other functions, and thus will not be available for data storage. Quantitative usage examples for various applications are for illustrative purposes. Actual quantities will vary based on various factors including file size, file format, features, and application software. Seagate reserves the right to change, without notice, product offerings or specifications.

Seagate Technology LLC
10200 S. De Anza Boulevard
Cupertino, CA 95014 U.S.A



Click here to access an up-to-date online version
of this document. You will also find the most recent content as well as expandable illustrations, easier navigation, and search capability.

Contents

1	Introduction	4
	Box content	4
	Minimum system requirements	4
2	Cables and Connectors	6
	USB-C	6
	Cables	6
	USB 3.1 (USB-C) cable	6
	USB 3.1 (USB-C)-to-USB Type A cable	7
3	Getting Connected	8
	STEP 1 - Connect the USB cable	8
	STEP 2 - LaCie Setup Assistant	9
	• Launch LaCie Setup Assistant - Mac	9
	• Launch LaCie Setup Assistant - Windows	9
	• LaCie Setup Assistant steps	10
4	Optional Formatting and Partitioning	12
	About file system formats	12
	Formatting instructions	12
	• Windows	13
	• Mac	13
5	Safely Remove Rugged USB-C From Your Computer	14
	Mac	14
	• Eject via Finder window	14
	• Eject via Desktop	14
	Windows	14
6	Frequently asked questions	16
	All users	16
	• Problem: My file transfers are too slow.	16
	• Problem: I have an older computer with USB 2.0 ports.	16
	• Problem: I must use a USB hub for my USB devices.	16
	• Problem: The provided USB cables are too short.	17
	• Problem: I must password protect and/or encrypt my hard drive	17
	• Problem: I'm receiving file transfer error messages.	17
	Mac	18

- Problem: The hard drive icon does not appear on my desktop. 18
- Windows** **18**
- Problem: The hard drive icon doesn't appear in Computer..... 18

Introduction

Welcome to the user manual for LaCie Rugged USB-C. The most portable of LaCie's field-tested Rugged hard drive range, Rugged USB-C gives you USB 3.1 Gen 1 transfer rates. Additionally, Rugged USB-C's casing is small and lightweight for easy travel and it withstands bumps and drops of up to 1.2 meters. Professionals and enthusiasts can appreciate LaCie Rugged USB-C's durability while enjoying high-end performance when connected to a computer with a USB 3.1 Gen 1 port.

Review this user manual for instructions how to connect your LaCie Rugged USB-C to your computer. For common questions and answers about your hard drive, please see [Frequently asked questions](#).

You can get the latest tips regarding your product and updated technical information at [LaCie customer support](#).

Box content

- LaCie Rugged USB-C
- USB 3.1 Gen 2 (USB-C) cable
- USB 3.1 Gen 1 (USB-C)-to-USB Type A cable (compatible with Type A USB 2.0 and USB 3.0 ports)
- Quick Install Guide
- Software: LaCie Backup Assistant



Note: A PDF of this user manual and software utilities are pre-loaded on the drive.



Important info: Save your packaging. If you experience problems with your hard drive and want to exchange it, the hard drive must be returned in its original packaging.

Minimum system requirements

You can connect your LaCie device to a computer that meets the following minimum requirements:

- Windows 7 or higher
- Mac OS X 10.7 or higher



Note: For optimal performance up to 5Gb/s, connect the product to a USB 3.1 Gen 1 or USB 3.0 host port on your computer. Connecting LaCie Rugged USB-C to a USB 2.0 port reduces performance to USB 2.0 transfer rates, up to 480Mb/s.

Cables and Connectors

USB-C

USB 2.0 480 Mb/s	USB 3.1 5 Gb/s	USB 3.1 10 Gb/s	DisplayPort Multi-Function 5 or 10 Gb/s	Thunderbolt 3 20 or 40 Gb/s
				

USB-C protocols

USB is a serial input/output technology for connecting peripheral devices to a computer. USB-C is the latest implementation of this standard and it provides higher bandwidth and new power management features.

USB-C supports many protocols:

- Thunderbolt 3: transfer rates up to 40Gb/s
- USB 3.1 Gen 2: transfer rates up to 10Gb/s
- USB 3.1 Gen 1: transfer rates up to 5Gb/s
- SuperSpeed USB 3.0: transfer rates up to 5Gb/s
- Hi-Speed USB 2.0: transfer rates up to 480Mb/s

The USB-C port on the LaCie Rugged USB-C is USB 3.1 Gen 1. You can connect Rugged USB-C to any USB-C or USB Type A port but transfer rates vary. See below for more details.

Cables

Your LaCie hard drive is shipped with two cables for universal compatibility with all modern computers:

- USB 3.1 Gen 2 (USB-C)
- USB 3.1 Gen 1 (USB-C)-to-USB Type A (USB 3.0 and USB 2.0)



For optimal transfer rates up to 5Gb/s, connect LaCie Rugged USB-C to a USB 3.1 port.

LaCie Rugged USB-C also supports connections to computers with USB Type A ports. Transfer rates with USB Type A connections have the potential to reach the speeds listed below.

- Hi-Speed USB 2.0: up to 480Mb/s
- SuperSpeed USB 3.0: up to 5Gb/s

USB 3.1 (USB-C) cable





Use the USB-C cable to ensure maximum data transfer rates with compatible ports. Connecting your product is easy since the USB-C cable is identical on both ends. Further, the USB-C ports on your LaCie hard drive and computer are conveniently rounded to accept the cable end no matter how it is connected.

Connector face	Cable end
	

USB 3.1 (USB-C)-to-USB Type A cable

Use the USB 3.1 (USB-C)-to-USB Type A cable for compatibility with computers that do not have a USB-C port. The USB-C end is connected to the LaCie hard drive and the Type A end is connected to the computer's USB 3.0 or USB 2.0 Type A port.

Hard drive performance is limited to USB 3.0 transfer rates when connected to a USB 3.0 port and, USB 2.0 transfer rates when connected to a USB 2.0 port

Connector face (USB Type A to computer)	Cable end (USB Type A to computer)	Cable end (USB-C to product)	Connector face (USB-C to product)
			

Getting Connected

Follow the setup steps in the order they are given to ensure that your LaCie hard drive's volume mounts correctly on your computer.

STEP 1 - Connect the USB cable

Before connecting LaCie Rugged USB-C, confirm the USB port on your computer. Your LaCie device is shipped with two cables (see [Cables and Connectors](#)):

- **USB-C:** use this cable if your computer has a USB-C port.
- **USB-C-to-USB Type A (USB 3.0/USB 2.0):** use this cable if your computer does not have a USB-C port.

Connect the cable to the USB-C port on LaCie Rugged USB-C and a USB port on your computer.

- The image below shows a connection to a computer with a USB-C port.

USB-C/USB-C

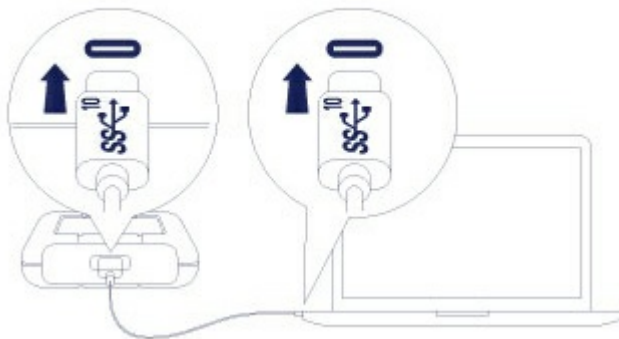

- The image below shows a connection to a computer with a USB 3.0/2.0 Type A port.

USB-C/USB 3.0 & 2.0

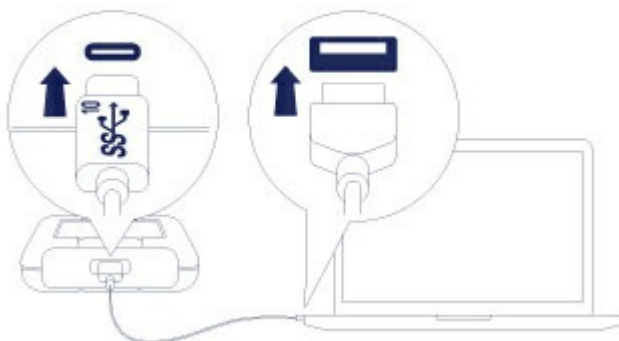

Note: If the drive does not mount on your computer, see troubleshooting topics in the [Frequently asked questions](#) section to help resolve common issues.

STEP 2 - LaCie Setup Assistant

LaCie Setup Assistant must be launched before using your drive. It will allow you to:

- Easily format the hard drive according to your needs.
- Register your LaCie device.
- Copy the user manual to the hard drive.
- Install software for added features.

i **Important info:** If you do not launch LaCie Setup Assistant or if you quit LaCie Setup Assistant after the formatting has begun, your drive will not be ready to use and will require manual formatting. Additionally, the user manual and utilities will not be available and must be downloaded from the [LaCie customer support](#).

Launch LaCie Setup Assistant - Mac

Open the **LACIE SETUP** volume on your desktop and then double click **LaCie Setup**.

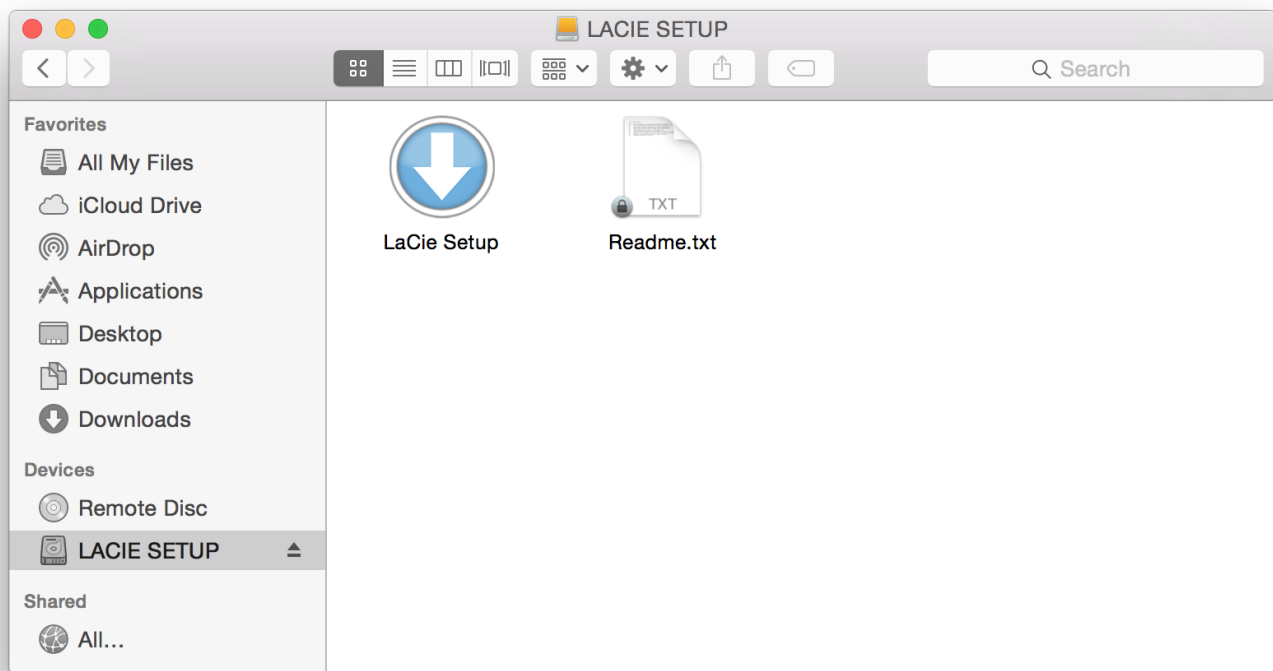

Launch LaCie Setup Assistant - Windows

AutoPlay: Windows AutoPlay may detect your LaCie hard drive as soon as it is connected to your computer. If the AutoPlay window appears, choose **Open folder** to view files using Windows Explorer and double-click **LaCie Setup**.

LaCie Setup (E:)

Choose what to do with removable drives.



Configure this drive for backup
File History



Configure storage settings
Settings



Open folder to view files
File Explorer



Take no action

Manual access: open the **LACIE SETUP** volume in a **Windows Explorer** window and double-click **LaCie Setup**.

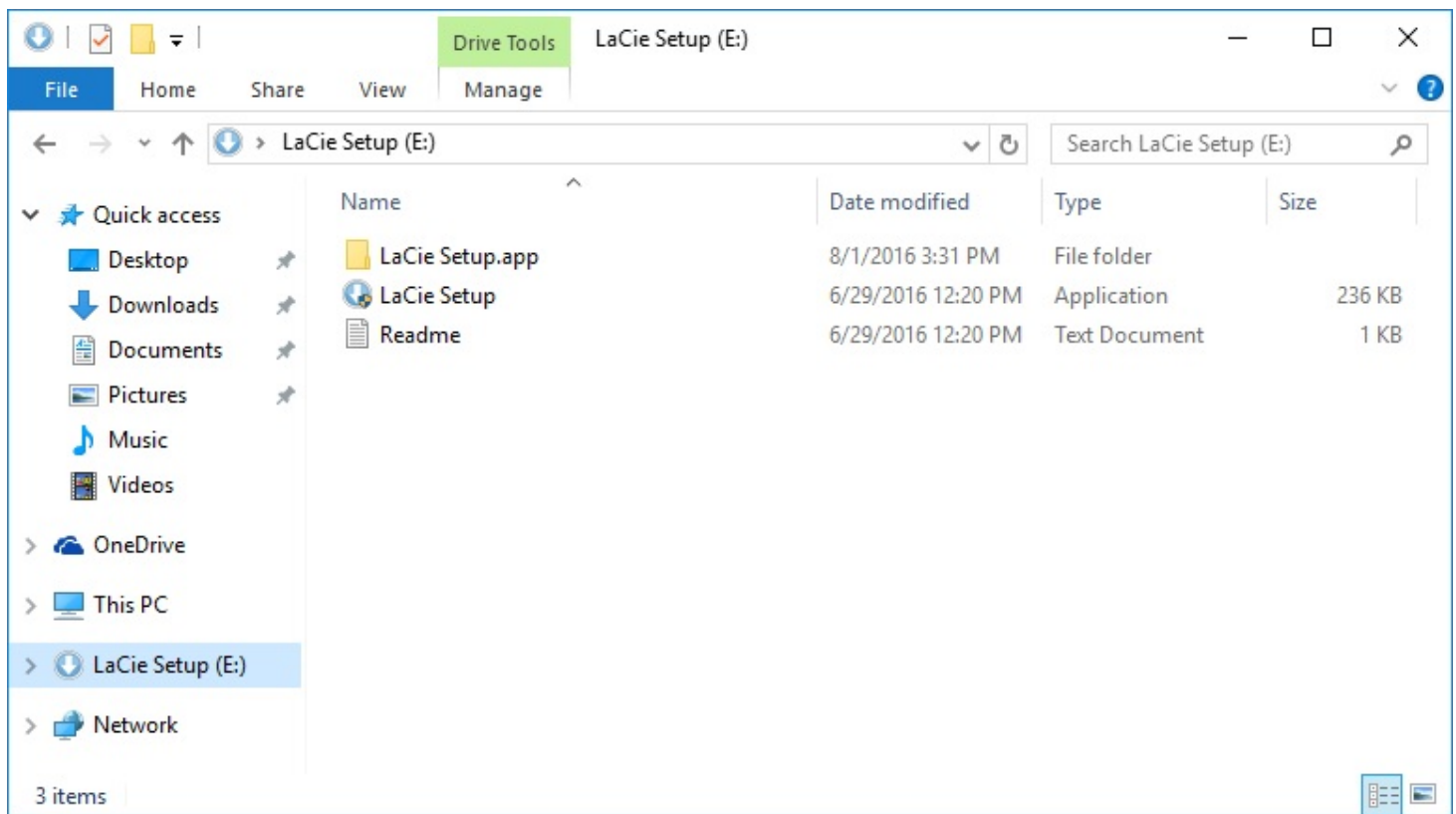

LaCie Setup Assistant steps

Follow the steps below to format your LaCie device for your operating system. LaCie Setup Assistant guides you through formatting and registering your hard drive as well as installing LaCie software utilities.

You can also use your system's native disk utility program to format or partition your LaCie drive. If you use the disk utility, you can download software utilities and the user manual from [LaCie customer support](#).

i **Important info for Mac users:** You may be prompted to enter your computer password to continue with LaCie Setup Assistant.

i **Important info for Windows users:** While running LaCie Setup Assistant, generic pop-up windows may ask if you wish to change your computer's settings. This is a normal request when formatting a hard drive or installing software. To successfully complete LaCie Setup Assistant, please agree to change the settings.

1. Select your language.
2. Read the license agreement before choosing **Next**. Selecting **Next** confirms that you accept the license agreement.
3. Use the slider to partition your LaCie hard drive. There are two options for partitions:
 - **LaCie Share:** formatted as FAT32 for compatibility with Windows and Mac.
 - **LaCie:** formatted for your operating system, NTFS for Windows or HFS+ for Mac.Move the slider to the left to reduce the size of the **LaCie Share** partition. If you do not want the **LaCie Share** volume, move the slider all the way to the left.
4. A prompt alerts you that the disk will be formatted. Select **Yes** to continue. LaCie Setup Assistant formats the hard drive.
5. Register your LaCie device.
6. Choose the software utilities that you want to install. Certain software utilities may begin to install before LaCie Setup Assistant has finished. Follow the software utility installer before completing LaCie Setup Assistant. If you do not install software utilities during this step, you can return to LaCie Setup Assistant at any time.
7. LaCie Setup Assistant provides a summary of the installation. Choose **Finish** to close the program.

To install software utilities after the initial installation, you can run LaCie Setup Assistant again. Since the format is complete you are only prompted to choose software utilities. LaCie Setup Assistant is available on:

- **LaCie Share:** if you created two partitions
- **LaCie:** if you created one partition

Optional Formatting and Partitioning

You can use LaCie Setup Assistant to format your LaCie hard drive when it is first connected to a computer (Mac or Windows). LaCie Setup Assistant helps you to quickly format the storage device according to your needs.

Read the information below if you:

- Aborted LaCie Setup Assistant while it was formatting.
- Want to reformat your storage device after successfully formatting the hard drive with LaCie Setup Assistant.

About file system formats

NTFS: since it is the native file system for Windows, volumes created in NTFS are read and write with computers running Windows. Mac OS can read NTFS volumes but cannot natively write to them.

Mac OS Extended (HFS+): the native hard drive file system for Mac. Windows cannot natively read or write to HFS+ (journaled) hard drives.

exFAT: generally compatible with Mac and Windows. exFAT is not a journaled file system which means it can be more susceptible to data corruption when errors occur or the drive is not disconnected properly from the computer.

FAT32: compatible with Mac and Windows. However, FAT32 is a legacy file system designed for low capacity hard drives and it is not recommended for modern hard drives or operating systems. A FAT32 partition can reach up to 32GB when formatted on a Windows PC.

How to choose the file system format

Use NTFS if:

...the storage device is connected to Windows PCs.

Use HFS+ if:

...the storage device is connected to Macs.

You can use exFAT if:

...the storage device is shared between Mac and Windows computers.

Use FAT32 if:

...the storage device is connected to older Windows and Mac computers. FAT32 is not recommended for modern operating systems and computers.

Formatting instructions

The steps below help you format and partition a storage device.

! **Caution:** Formatting erases everything on the storage device. LaCie highly recommends that you back up all data on your storage device before performing the steps below. LaCie is not responsible for any data lost due to formatting, partitioning or using a LaCie storage device.



Note: Refer to your operating system's documentation for more information on formatting and partitioning storage devices.

Windows

1. Make sure the storage device is connected to and mounted on the computer.
2. Go to Search and then type **diskmgmt.msc**. In the search results, double click **Disk Management**.
3. From the list of storage devices in the middle of the Disk Management window, locate your LaCie device.
4. The partition must be available to format. If it is currently formatted, right click on the partition and then choose **Delete**.
5. To create a new partition, right click on the volume and select **New Simple Volume**. Follow the on-screen instructions when the New Simple Volume Wizard appears.

Mac

1. Make sure the storage device is connected to and mounted on the computer.
2. Select **Go > Utilities** in the Finder menu bar.
3. In the Utilities folder, double-click **Disk Utility**.  All connected storage devices, partitions or disk images are displayed in the left column.
4. Select the LaCie hard drive in the left column.
5. Click the **Erase** tab.
6. Choose a format from the drop-down window.
7. Enter a name for the volume.
8. Click **Erase** and confirm your selection in the pop-up window.

Safely Remove Rugged USB-C From Your Computer

Always eject a storage drive from your computer before physically disconnecting it. Your computer must perform filing and housekeeping operations on the drive before it is removed. Therefore, if you unplug the drive without using the operating system's software, your files can become corrupt or damaged.

Mac

There are several ways you can eject your hard drive from a Mac. See below for two options.

Eject via Finder window

1. Open a Finder window.
2. On the sidebar, go to Devices to locate LaCie and click the eject symbol to the right of the drive name.
3. Once the hard drive disappears from the sidebar or, the Finder window closes, you can disconnect the hard drive's cable from your Mac.

Eject via Desktop

1. Select the desktop icon for your hard drive and drag it to the Trash.
2. When the hard drive's icon is no longer visible on your desktop, you can physically disconnect the hard drive from your Mac.

Windows

Use the Safely Remove tool to eject a hard drive.

1. Click the Safely Remove icon in your Windows System Tray to view the devices you can eject.

- Windows 7:

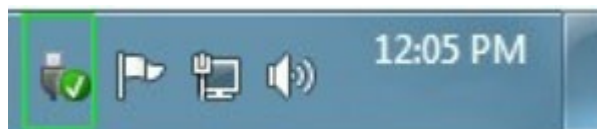

- Windows 8 / Windows 10:

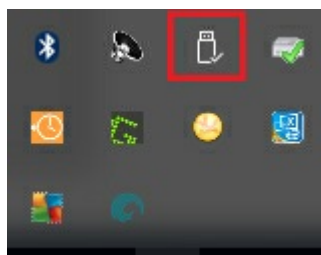

2. If you don't see the Safely Remove Hardware icon, click the **Show hidden icons arrow** in the system tray to display all icons in the notification area.
3. In the list of devices, choose the device you want to remove. Windows displays a notification when it is safe to remove the device.
4. Disconnect the hard drive from the computer.

Frequently asked questions

For help setting up and using your LaCie hard drive, review the frequently asked questions below. For additional support resources, go to [LaCie customer support](#).

All users

Problem: My file transfers are too slow.

Q: Are both ends of the USB cable firmly attached?

A: Review troubleshooting tips for cable connections below:

- Check both ends of the USB cable and make sure that they are fully seated in their respective ports.
- Try disconnecting the cable, waiting 10 seconds, and then reconnecting it.
- Try a different USB cable.

Q: Is the hard drive connected to a Hi-Speed USB 2.0 port on your computer or hub?

A: If your hard drive is connected to a Hi-Speed 2.0 port or hub, the inferior performance is normal. LaCie Rugged USB-C performance will improve when it is connected to a USB 3.1 port or a SuperSpeed USB 3.0 port. Otherwise, LaCie Rugged USB-C operates at slower USB transfer rates.

Q: Are there other USB devices connected to the same port or hub?

A: Disconnect other USB devices and see if the hard drive's performance improves.

Problem: I have an older computer with USB 2.0 ports.

Q: Will my hard drive's USB 3.1 Gen 1 port work with my computer's USB 2.0 port?

A: Yes, the cable end that plugs into the computer (USB Type A) is compatible with both USB 3.0 and USB 2.0. Make certain to use the included cable with the correct USB Type A connector. However, the transfer rates are much slower with USB 2.0.

Problem: I must use a USB hub for my USB devices.

Q: Can I use my hard drive with a USB hub?

A: Yes, the hard drive can be connected to a USB hub. If you use a hub and encounter detection problems, slower than normal transfer rates, random disconnection from your computer or other unusual issues, try connecting the hard drive directly to the computer's USB port.

Some USB hubs are less than efficient with power management, which can be problematic for connected devices. In such a case, consider trying a powered USB hub that includes a power cable.

Please note that USB 2.0 hubs limit your hard drive's transfer rates to USB 2.0 speeds.

Problem: The provided USB cables are too short.

Q: Can I use my hard drive with a longer cable?

A: Yes, provided it is certified according to USB standards. However, LaCie recommends using the cable shipped with your hard drive for the best results. If you use a longer cable and experience problems with detection, transfer rates or disconnection, use the original cable included with your hard drive.

Problem: I must password protect and/or encrypt my hard drive

Q: Can I protect my hard drive with a password?

A: Yes, it is possible to protect the hard drive or individual folders and files with a password. There are many third-party solutions for password protection. However, LaCie cannot guarantee them since we do not test third-party applications.

Some versions of Windows have a built-in utility called Bitlocker that can protect hard drives with a password. For more information about Bitlocker, consult [Microsoft's support documentation](#).

Q: Can I encrypt my hard drive?

A: Yes, the hard drive can be encrypted. There are many third-party solutions for encryption. However, LaCie cannot guarantee them since we do not test third-party applications.

Some versions of Windows have a built-in utility called Bitlocker that can encrypt hard drives. For more information about Bitlocker, consult [Microsoft's support documentation](#)

Problem: I'm receiving file transfer error messages.

Q: Did you get an "Error -50" message while copying to a FAT32 volume?

A: When copying files or folders from a computer to a FAT32 volume, certain characters in the names cannot be copied. These characters include, but are not limited to: ? < > / \ :

Check your files and folders to ensure that these characters are not in the names.

If this is a recurring problem or you cannot find files with incompatible characters, consider reformatting the drive to NTFS (Windows users) or HFS+ (Mac users). See [Optional Formatting and Partitioning](#).

Q: Did you get an error message telling you that the drive has been disconnected when coming out of sleep mode?

A: Ignore this message since the drive remounts on the desktop despite the pop-up. LaCie drives conserve power by spinning down when you set your computer to sleep mode. When the computer awakes from sleep mode, the drive may not have enough time to spin up, causing the pop-up to appear.

Mac

Problem: The hard drive icon does not appear on my desktop.

Q: Is your Finder configured to hide hard drives on the desktop?

A: Go to Finder and then check **Preferences > General tab > Show these items on the desktop**. Confirm that **Hard Disks** is selected.

Q: Is your hard drive mounting in the operating system?

A: Open Disk Utility at **Go > Utilities > Disk Utility**. If the hard drive is listed in the left-hand column, check your Finder preferences to see why it is not displayed on the desktop (review the question above).

Q: Does your computer's configuration meet the minimum system requirements for use with this hard drive?

A: Refer to the product packaging for the list of supported operating systems.

Q: Did you follow the correct installation steps for your operating system?

A: Review the installation steps in [Getting Connected](#).

Windows

Problem: The hard drive icon doesn't appear in Computer.

Q: Is the hard drive listed in Device Manager?

A: All drives appear in at least one place in Device Manager.

Go to [Device Manager](#) to type **Device Manager** and then launch it. Look in the **Disk Drives** section and, if necessary, click the plus sign to view the full list of devices. If you're uncertain that your drive is listed, safely unplug it and then reconnect it. The entry that changes is your LaCie hard drive.

Q: Is your hard drive listed next to an unusual icon?

A: Windows Device Manager usually provides information about failures with peripherals. While the Device Manager can assist with troubleshooting most problems, it may not display the exact cause or provide a precise solution.

An unusual icon next to the hard drive can reveal a problem. For example, instead of the normal icon based on the type of device, it has an exclamation point, question mark or an X. Right click this icon and then choose **Properties**. The General tab provides a potential reason why the device is not working as expected.