

iKON Series Amplifiers

User Guide



iKON





Martin Audio iKon Amplifier User Guide

Contents

Martin Audio iKon Amplifier User Guide	1
Contents	1
IMPORTANT SAFETY INSTRUCTIONS	5
CONSIGNES DE SÉCURITÉ IMPORTANTES.....	6
AVERTISSEMENT DE SECURITE	6
AVERTISSEMENT DE SECURITE	6
AVERTISSEMENT DE SECURITE	6
COMPLIANCE	7
FOR CUSTOMERS IN EUROPE.....	7
FOR CUSTOMERS IN THE USA	7
FOR CUSTOMERS IN CANADA.....	8
Thanks and Unpacking.....	8
Unpacking the Martin Audio iK42/iK81 Series Amplifier	8
INSTALLATION INSTRUCTIONS.....	9
Mechanical Installation.....	9
AC Power Connection.....	10
The User Guide	11
Introduction and Key Features	12
Introduction.....	12
Key Features	12
Audio Connections.....	14
Input Connections	14
Using unbalanced connections	14
Amplifier Output Connections.....	14
Load Matching	16
Panel Layouts.....	17
Quick start	20
Loading XE500 (or XE300 Bi-amp) Presets.....	20
Loading XE300 Passive Presets	21
Operation	23
Starting up the unit.....	23
Overview of Modules, Presets Components and Snapshots	23
Navigation.....	24
The Home Page.....	25
Drive Modules	25



Drive Module Presets	25
Component Presets	25
Factory Module Presets	25
Storing Module Presets	26
Recalling Module Presets	26
Recalling Components	26
Input	27
AES3 Inputs	27
Dante™ Inputs	27
Automatic Input Selection (Failover)	27
Gain and Polarity	27
Delay	28
High Pass Filter	28
Parametric Equalisation	28
FIR Shelving EQ	28
Parametric Filters	28
Routing	28
Output	29
Gain and Polarity	29
Delay	29
High and Low pass Filters	29
LIR Crossover Filtering	29
Parametric Equalisation	29
Limiters	29
VX Limiter	29
Tmax Thermal Limiter	30
Xmax Excursion Limiter	30
Bridge	30
Routing	31
Driver	31
Utility Pages	32
Screen Contrast	32
Stereo Linking	32
Current Ethernet IP Address	32
IP Mode	32
IP Static	32
Store Snapshot	32
Recall Snapshot	32
Bandwidth Units	32



Aux Style	32
ECO	32
External Breaker Protection (EBP)	33
Ethernet	33
Ethernet configurations	33
DHCP	33
AUTO-IP	33
Static-IP	33
IP Troubleshooting	33
Snapshots	34
AUX Port	34
Latency delay	35
Secure Mode	36
Overlay Flush	36
Revert to Factory Settings	36
Protection Systems	36
Summary of Protection Indication	36
Incident Reporting	37
Fault Relay	37
Performance Logging	37
Vu-Net	38
TIPI Control	39
Protocol Overview	39
Physical layer	39
General frame format	39
Addressing	39
Commands	40
Responses	40
MethodNames	40
Security	40
Parameter Values	40
Script Examples	41
Tipi Methods for IKON Amplifiers	41
Power Draw & Thermal Dissipation	42
iK42	42
iK81	43
Processing Block Diagram	44
Input Menu Map	45
Output Menu Map	46



Utility Menu Map	47
EQ and Filter Response Graphs	48
Technical Specifications.....	51
General	51
Audio	51
Digital processing.....	51
Power Output iK42	52
Power Output iK81	52
Power supply	52
Protection systems	52
Power distribution protection systems	52
Monitoring and logging	52
Physical	53
Options	53

IMPORTANT SAFETY INSTRUCTIONS



CAUTION

RISK OF ELECTRIC SHOCK
DO NOT OPEN

DO NOT EXPOSE TO
RAIN OR MOISTURE

ATTENTION

RISQUE DE CHOC ELECTRIQUE
NE PAS ENLEVER

NE PAS EXPOSER A LA
PLUIE NI A L'HUMIDITE



1. Read these instructions.
2. Keep these instructions.
3. Heed all warnings.
4. Follow all instructions.
5. Do not use this apparatus near water.
6. Clean only with dry cloth.
7. Do not block any ventilation openings. Install in accordance with the manufacturer's instructions.
8. Do not install near any heat sources such as radiators, heat registers, stoves or other apparatus (including amplifiers) that produce heat.
9. Do not defeat the safety purpose of the polarized or grounding type plug. A polarized plug has two blades with one wider than the other. A grounding type plug has two blades and a third grounding prong. The wide blade or the third prong are provided for your safety. If the provided plug does not fit into your outlet, consult an electrician for replacement of the obsolete outlet.
10. Protect the power cable from being walked on or pinched particularly at plugs, convenience receptacles and the point where they exit from the apparatus.
11. Only use attachments / accessories specified by the manufacturer.
12. Use only with the cart, tripod, bracket or table specified by the manufacturer, or sold with the apparatus. When a cart is used, use caution when moving the cart / apparatus combination to avoid injury from tip-over.
13. Unplug this apparatus during lightning storms or when unused for long periods of time.
14. Refer all servicing to qualified service personnel. Service is required when the apparatus has been damaged in any way, such as power-supply cable or plug damaged, liquid has been spilled or objects have fallen into the apparatus, this apparatus has been exposed to rain or moisture, does not operate normally, or has been dropped.

SAFETY WARNING

Do not remove any covers, loosen any fixings or allow items to enter any aperture.

SAFETY WARNING

The rear of the product may get hot. Avoid direct skin contact during operation and for at least 5 minutes after power has been isolated.

SAFETY WARNING

The product must only be positioned at floor level when operated in a horizontal position.

CONSIGNES DE SÉCURITÉ IMPORTANTES



CAUTION

RISK OF ELECTRIC SHOCK
DO NOT OPEN

DO NOT EXPOSE TO
RAIN OR MOISTURE

ATTENTION

RISQUE DE CHOC ELECTRIQUE
NE PAS ENLEVER

NE PAS EXPOSER A LA
PLUIE NI A L'HUMIDITE



1. Lisez ces instructions.
2. Conservez ces instructions.
3. Respectez tous les avertissements.
4. Suivez toutes les instructions.
5. Ne pas utiliser cet appareil près de l'eau.
6. Nettoyer uniquement avec un chiffon sec.
7. Ne pas bloquer les ouvertures de ventilation. Installer conformément aux instructions du fabricant.
8. Ne pas installer près de sources de chaleur telles que radiateurs, registres de chaleur, poêles ou autres appareils (y compris les amplificateurs) qui produisent de la chaleur.
9. Ne supprimez pas le dispositif de sécurité de la fiche polarisée ou mise à la terre. Une fiche polarisée possède deux lames dont l'une est plus large que l'autre. Une prise de terre a eu deux lames et une troisième broche de terre. La lame large ou la troisième broche sont fournies pour votre sécurité. Si la fiche fournie ne rentre pas dans votre prise, consultez un électricien pour remplacer la prise obsolète.
10. Protéger le cordon d'alimentation soit écrasé ou pincé, particulièrement au niveau des fiches, des prises et le point où ils sortent de l'appareil.
11. Utilisez uniquement les accessoires spécifiés par le fabricant.
12. Utilisez uniquement le chariot, le trépied, le support ou la table spécifiés par le fabricant, ou vendu avec l'appareil. Quand un chariot est utilisé, soyez prudent lorsque vous déplacez l'ensemble chariot / appareil afin d'éviter toute blessure en cas de chute.
13. Débranchez cet appareil pendant les orages ou lorsqu'il n'est pas utilisé pendant de longues périodes de temps.
14. Adressez-vous à un personnel qualifié. Une réparation est requise lorsque l'appareil a été endommagé de quelque façon que ce soit le cordon d'alimentation ou la fiche endommagé, du liquide a été renversé ou des objets sont tombés dans l'appareil, cet appareil a été exposé à la pluie ou à l'humidité, ne fonctionne pas normalement, ou s'il est tombé.
15. Le dispositif ne doit pas être exposé à des gouttes ou des éclaboussures et aucun objet rempli de liquides, tels que des vases, doit être placé sur l'appareil.
16. Déconnexion permanente de l'alimentation secteur doit être atteint en supprimant le connecteur du cordon fourni à l'arrière de l'unité. Ce connecteur doit être facilement utilisable.

AVERTISSEMENT DE SECURITE

Ne retirez pas les couvercles, ne desserrez pas les fixations et ne laissez aucune pièce s'introduire dans les ouvertures.

AVERTISSEMENT DE SECURITE

Le radiateur arrière de cet appareil devient chaud. Evitez tout contact direct avec la peau pendant le fonctionnement et au moins 5 minutes après la mise hors tension de l'appareil.

AVERTISSEMENT DE SECURITE

Le produit ne doit être positionné au niveau du sol lorsqu'il est utilisé en position horizontale.



COMPLIANCE

FOR CUSTOMERS IN EUROPE

This product complies with both the LVD (electrical safety) 73/23/EEC and EMC (electromagnetic compatibility) 89/336/EEC directives issued by the Commission of the European Community.

Compliance with these directives implies conformity with the following European standards:

EN60065 Product safety

EN55103-1 EMC emissions

EN55103-2 EMC immunity

This product is intended for the following electromagnetic environments: E1, E2; E3 & E4.

THIS PRODUCT MUST BE EARTHED. Use only a flexible cable or cord with a green and yellow core which must be connected to the protective earthing terminal of a suitable mains plug or the earthing terminal of the installation. The cord must be a maximum of 2m long, have a 2.5mm² CSA, a 300/500V rating and comply with EN50525-2-11 / H05W-F.

THIS PRODUCT IS DESIGNED FOR PERMANENT INSTALLATION. It must be fitted in to a 19" rack enclosure and not operated unless so installed. The rack enclosure should be open at the front and back to allow free ventilation and movement of air through the product.

FOR CUSTOMERS IN THE USA

This product complies with UL60065 7th edition.

THIS PRODUCT MUST BE EARTHED. Use only a flexible cable or cord with a green or green / yellow core which must be connected to the protective earthing terminal of a suitable mains plug or the earthing terminal of the installation. The cord must be a maximum of 6' long, be 14AWG, have a rating SJ, SJT, SJE or 300/500V H05W-F and be marked VW-1.

THIS PRODUCT IS DESIGNED FOR PERMANENT INSTALLATION. It must be fitted in to a 19" rack enclosure and not operated unless so installed. The rack enclosure should be open at the front and back to allow free ventilation and movement of air through the product.

DECLARATION OF CONFORMITY WITH FCC RULES

We, Martin Audio Ltd. of Century Point, Halifax Road, Cressex Business Park, High Wycombe, HP12 3SL, England, declare under our sole responsibility that this family of devices, complies with Part 15 of the FCC Rules. Operation is subject to the following two conditions: (1) this device may not cause harmful interference, and (2) this device must accept any interference received, including interference that may cause undesired operation.

FEDERAL COMMUNICATIONS COMMISSION NOTICE

An example of this equipment has been tested and found to comply with the limits for a Class B digital device, pursuant to Part 15 of the FCC Rules. These limits are designed to provide reasonable protection against harmful interference in a residential and commercial installation.

This equipment generates, uses, and can radiate radio frequency energy, and if not installed and used in accordance with the instructions, may cause harmful interference to radio communications. However, there is no guarantee that interference will not occur in a particular installation. If this equipment does cause harmful interference to radio or television reception, which can be determined by turning the equipment off and on, the user is encouraged to try and correct the interference by one or more of the following measures:

- Reorient or relocate the receiving antenna.
- Increase the distance between the equipment and the receiver.
- Connect the equipment to an outlet on a circuit different from that to which the receiver is connected.
- Consult the dealer or an experienced radio/TV technician for help.

FCC Caution: Any changes or modifications not expressly approved by the party responsible for compliance could void the user's authority to operate this equipment.



FOR CUSTOMERS IN CANADA

This product complies with CA /CSA C22.2 No.60065-03

Ce produit est conforme avec CA /CSA C22.2 No.60065-03

THIS PRODUCT MUST BE EARTHED. Use only a flexible cable or cord with a green or green / yellow core which must be connected to the protective earthing terminal of a suitable mains plug or the earthing terminal of the installation. The cord must be a maximum of 6' long, be 14AWG, have a rating SJ, SJT, SJE or 300/500V H05W-F and be marked VW-1.

CE PRODUIT DOIT ÊTRE MIS À LA TERRE. Utilisez uniquement un câble souple avec un noyau vert ou vert / jaune qui doit être relié à la borne de terre de connecteur d'alimentation ou la borne de terre de l'installation. Le cordon doit être un maximum de 6' (2m) de long, 14 AWG (2.5mm² CSA), être classé SJ, SJT, SJE ou 300/500V H05W-F et être marquée VW-1

THIS PRODUCT IS DESIGNED FOR PERMANENT INSTALLATION. It must be fitted in to a 19" rack enclosure and not operated unless so installed. The rack enclosure should be open at the front and back to allow free ventilation and movement of air through the product.

CE PRODUIT EST CONÇU POUR UNE INSTALLATION PERMANENTE. Il doit être installé dans un boîtier rack 19 ". Le rack devrait être ouvert à l'avant et l'arrière pour permettre la ventilation et le mouvement d'air libre à travers le produit .

DECLARATION OF CONFORMITY WITH CANADIAN ICES-003

This Class B digital apparatus complies with Canadian ICES-003.

Cet appareil numérique de la classe B est conforme à la norme NMB-003 du Canada.

Thanks and Unpacking

Thank you for choosing a Martin Audio iK42/iK81 Series Advanced System Amplifier for your application. Please spare a little time to study the contents of this manual, so that you obtain the best possible performance from this unit.

All Martin Audio products are carefully engineered for world-class performance and reliability.

If you would like further information about this or any other Martin Audio product, please contact us. We look forward to helping you in the near future.

Unpacking the Martin Audio iK42/iK81 Series Amplifier

After unpacking the unit please check carefully for damage. If damage is found, please notify the carrier concerned at once. You, the consignee, must instigate any claim. Please retain all packaging in case of future re-shipment.

INSTALLATION INSTRUCTIONS

Mechanical Installation

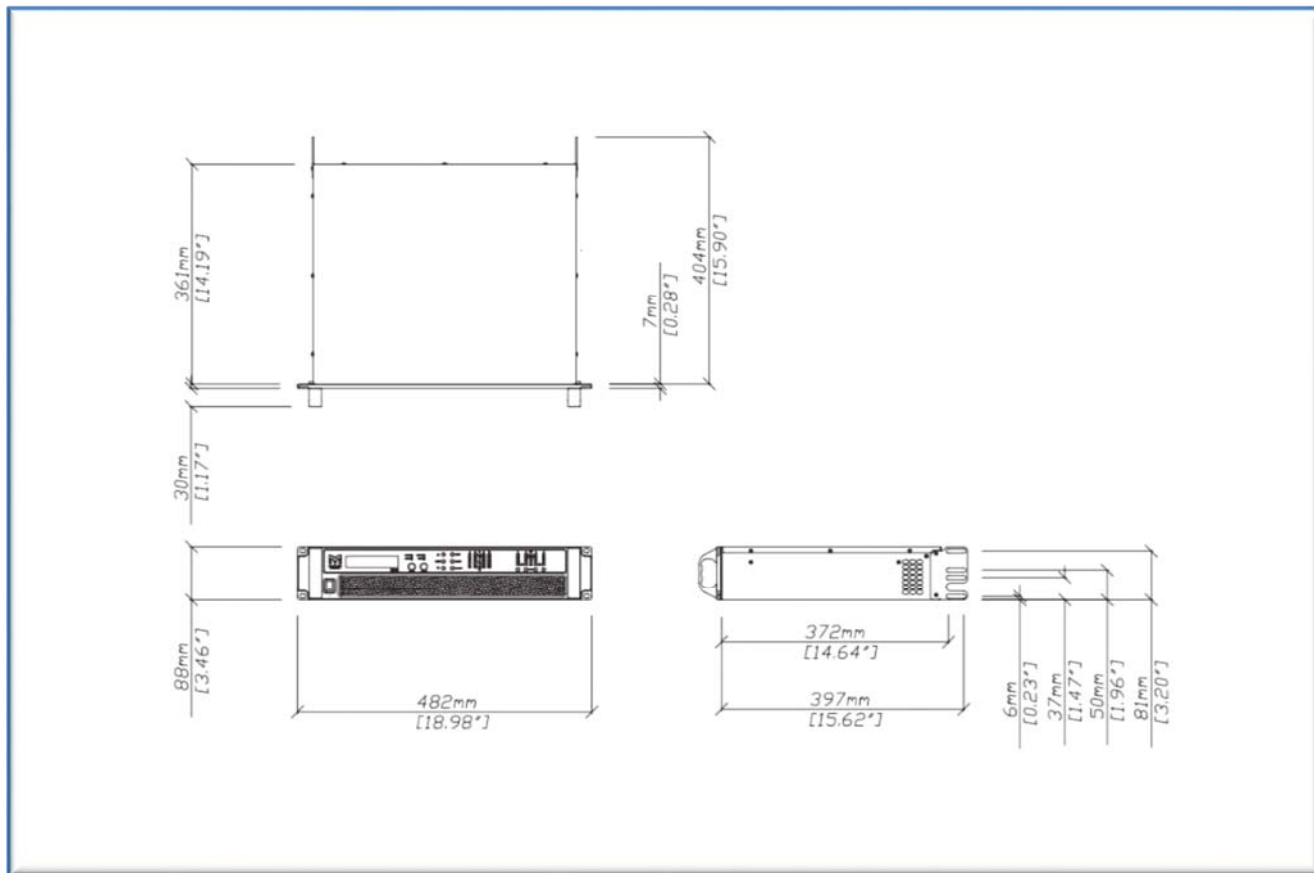

The iK42/iK81 Series Amplifier system is designed to be mounted in a standard 19" rack enclosure.

Where the amplifier is used in a fixed installation, as long as the bottom unit is supported and there are no gaps between units, it is acceptable to use only the front panel 19" rack holes when fitting it in a standard rack enclosure. If the amplifier is mounted in a mobile rack it is important that the rear is supported with a rear rack mounting kit (part number IKRACK). Damage caused by insufficient support is not covered by the warranty.

To prevent damage to the front panel it is recommended that plastic cups or washers are fitted underneath the rack mounting bolt heads.

It is possible to mount multiple iK42/iK81 Series amplifiers without ventilation gaps between them but it is essential that an unobstructed flow of clean air is available from the front of the unit to the rear. It is important that neither the air intakes on the front of the unit or the exhaust vents at the rear are covered. Steps must be taken to ensure that hot air does not continually circulate through the amplifiers from the back of the rack to the front.

The amplifier should never be exposed to rain or moisture during operation or storage. If the unit does come into contact with moisture, remove the AC power cable immediately and leave it in a dry and warm location to dry out.

Note that when any equipment is taken from a cold location into a hot humid one, condensation may occur inside the device. Always allow time for the equipment to attain the same temperature as its surrounding environment before connecting the AC power cable.

IMPORTANT

It is the responsibility of the user to ensure that dirt, liquids and vapour from theatrical smoke and fog machines is not ingested by the amplifier. Damage so caused is not covered by the manufacturer's warranty.

AC Power Connection

The amplifier utilises a 32A Neutrik PowerCon™ type locking AC power connector. Use only an AC power cable with a correctly terminated PowerCon™ type connector to make the connection to the mains power supply.

The amplifiers are designed to operate on 50/60 Hz AC power. The power supply sections automatically configure themselves for either 115V or 230V nominal voltage at turn on. The amplifiers will operate over an extended range of supply voltages (please refer to the technical specifications). The thresholds of these ranges are as follows; -

115V range: 75 - 138Vrms

230V range: 138 - 275Vrms

Note that whilst the amplifier will operate correctly at voltages indicated, the specified output power will only be achieved when operating with the stated nominal voltages.

Once an amplifier has configured itself for a particular range it will not change range, even if the mains voltage varies wildly, unless power is completely interrupted for several seconds or is cycled by the user.

During start-up the amplifier assesses the mains environment, displaying one of the following messages if a problem is detected with the quality of the incoming mains supply.

Problem and IKON LCD screen Message	Description of the problem
Mains too low	During start-up the unit waits for the mains to settle within either the 115V or 230V ranges. If the mains is taking a long time to settle and the voltage measured is <i>below</i> the 115V range this message is displayed.
Mains too high	During start-up the unit waits for the mains to settle within either the 115V or 230V ranges. If the mains is taking a long time to settle and the voltage measured is <i>above</i> the 230V range this message is displayed.
Mains unstable	During start-up the unit waits for the mains to settle within either the 115V or 230V ranges and remain there for a settling time. If the mains is taking a long time to settle but the voltage measured is currently in either the 115V or 230V ranges this message is displayed.

When an amplifier is running normally the mains is continuously monitored to ensure that it remains within the initially selected range. If the mains voltage is outside that range the amplifier will enter a protection mode and briefly display the message below. When in this mode audio will be muted but communication will still be possible.

Fault: Mains out of range	Amplifier was running but the measured mains voltage was outside the initial range.
----------------------------------	---

While in a protection mode caused by an unstable mains supply the amplifier will continually monitor the mains and automatically resume normal operation if it is assessed to be stable and within the initial range selected when the unit was first powered up. While the mains remains out of range one of the messages above will be displayed



The User Guide

This user manual gives a progressively more detailed description of the functions of the Martin Audio iK42/iK81 Series Advanced System Amplifiers. A single page quick reference guide is provided for those users who are experienced with this type of equipment and just need to know how to 'drive' the front panel. A detailed explanation of the front and rear panel controls and indicators is contained in the next section.

The final section describes each individual function or feature with annotated images explaining its use. Where appropriate, the graphical display is shown to further elaborate on the units operation.

To complete the manual a reference section is included, describing the technical performance of the device complete with graphs of filter responses.

Introduction and Key Features

Introduction

The Martin Audio iK42/iK81 Series Advanced System Amplifier represents current state-of-the-art technology in several areas. This product is the result of several years of research, from which many advances in switched mode power technologies and ever finer detail in signal processing have stemmed. Taking advantage of the latest advances in analogue to digital conversion technologies, the unit achieves performance levels among the very best that engineering permits.

Below is a list of key features, followed by some information on the major advanced features of the product.

Key Features

- Four/Eight channels of sonically pure Class D amplification
- Very high power density - packs four channels and 20kW or eight channels and 10kW into just 2U of rack space
- Packed with robust protection and monitoring systems to keep the show going
- External Breaker Protection (EBP) limits the current draw to prevent breakers opening
- Martin Audio minimal signal path design
- Class leading sonic performance achieved by the use of state of the art Amplifier technologies and highly advanced DSP algorithms using Linea Micro Detail (LMD)
- 96kHz sampling frequency provides for a nominally flat response beyond 40kHz.
- Rotary encoders, illuminated buttons and graphical display provide a rapid, intuitive and user-friendly control interface
- High speed Ethernet communications supporting DHCP, static-IP and auto-IP and direct connection to a computer without the need for a router or a switch
- Powerful Drive Module concept, abstraction from device centric to speaker based control
- Innovative Component Presets to allow individual outputs to be used for selected drivers of a loudspeaker system
- Twelve layers of Parameter Overlays for trouble-free Grouping
- Unique VX limiter providing dynamic control for passive 2-way enclosures
- Unique LIR linear phase crossover shapes giving FIR-like performance without the drawbacks
- Linear phase HF system EQ profiling which provides perfect integration between enclosures
- Innovative excursion control limiter with sliding High Pass Filter; limits only the damaging low frequencies
- Transducer thermal modelling provides regulation limiters, addressing long term overload
- Overshoot limiter governs amplitude of transient signals retaining average power whilst constraining peak energy
- Dante audio networking with automatic fall-over to Analogue or AES3
- AES3 inputs

Drive Modules

The iK42/iK81 Series processor has a new way of ordering and grouping channels in order to give a more speaker-based approach to controlling, designing and recalling speaker configurations; these are called Drive Modules. A Drive Module is the Processing provided by one Input DSP Block, and a number of Output DSP Blocks, which are associated with one-another by means of routing. For example, if Input DSP Block B is routed to Outputs 3 and 4, then this is a 2-way Drive Module with Input DSP Block B forming the 'Master' control, and Output DSP Blocks 3 and 4 providing the driver-related control. Overall, this forms the processing typically for one loudspeaker sub-system. The Vu-Net Drive Module control panel for this sub-system may then be used for control and monitoring of the associated speaker.

Drive Modules may be included in Module Groups, which use the Parameter Overlay feature in the Device to achieve trouble-free Grouping in the Vu-Net application.

The Presets in the Device are Drive-Module centric, and are used to configure individual Drive Modules rather than the whole device.

Importantly, Drive Modules move the focus away from the processing device, and onto the loudspeaker systems.

A Drive Module Preset may be broken apart into Components, allowing any output to be used for any component within a Drive Module Preset (i.e. any driver in a loudspeaker subsystem).

See Overview of Modules

Overlays



When the Device is used in Modules view in Vu-Net, this allows the modules to be grouped into Overlay Groups. These groups allow various Input (master) parameters to be adjusted in all modules in that group, whilst maintaining independent parameter values across each group. This is achieved in the device by combining the parameters for all the layers for a given section (Gain Delay, EQ etc.). When an Overlay parameter is active, the Overlay indicator will become illuminated. The combined Gain or Delay etc. associated with a given section is shown on the module panel in Vu-Net, within square brackets [] under the Delay and Gain for each input channel. The combined EQ curve is shown in an olive colour. The Input Mute button in Vu-Net will flash if an overlay mute is active. On the device, the presence of an active overlay is generally indicated by square brackets “[]” after the parameter value on the display. An input overlay mute is indicated on the mute/clip indicator for that channel flashing. Note that overlay parameters cannot be adjusted on the Device itself; these can only be controlled by the Vu-Net application. However, overlay parameters may be removed on the device – see Overlay Flush. Note that overlays are not stored in presets or snapshots or carried in settings files.

LIR Linear Phase Crossover Filtering The Device also includes a new type of crossover filtering “Linear Impulse Response” (LIR) crossover filtering, which results in a Linear Phase crossover that has a constant delay regardless of frequency (unlike other types of crossover which delay different frequencies to a different extent, thus smearing the arrival time). The LIR crossover can thus be described as having a flat Group Delay response, and thus entirely free of Group Delay Distortion.

The shape of the LIR crossover filter is quite similar to a 4th order or 24dB/Oct Linkwitz-Riley filter, and maintains zero phase difference between the adjacent bands across the crossover region to keep the polar response rock steady.

FIR Linear Phase Equalisation

The Input High-Shelf Equalisers use Finite Impulse Response (FIR) filtering to produce Linear Phase equalisation; that is all frequencies are delayed by the same amount, perfectly preserving the transient response. This can also be important in applications where different amounts of EQ are applied to different parts of a speaker cluster, such as to add 'Throw' EQ boost so that parts of cluster which are throwing further can have HF absorption correction added. If this EQ is not linear phase, then the zones where the speakers combine may suffer frequency response anomalies.

Audio Connections

Input Connections

For each input channel there is a female XLR connector for analogue inputs. There is also one female XLR for one stream (two channels) of AES3 digital audio. Note that only two channels of AES3 digital audio are available. The Dante option permits more channels of Digital Audio inputs.

The HOT, + or 'in phase' connection should be made to pin 2 of the XLR connector.

The COLD, - or 'out of phase' connection should be made to pin 3 of the XLR connector.

Pin 1 of the XLR connectors is internally connected to the chassis. The shield of the input cable should always be connected Pin 1 of the XLR to ensure that EMC performance and regulations are met.

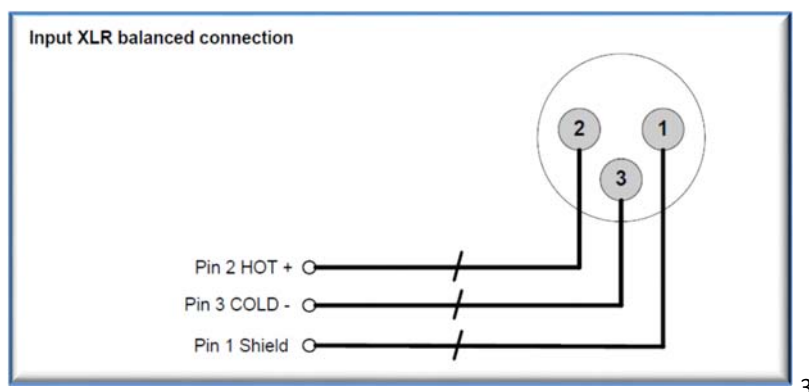

Using unbalanced connections

Please note that the use of unbalanced connections is not recommended, however when connecting the amplifier to an unbalanced audio source, the signal conductor should be connected to XLR pin 2. The 'Cold' conductor or cable screen should be connected to XLR pin 1 with a short connection made between pin 1 and pin 3.

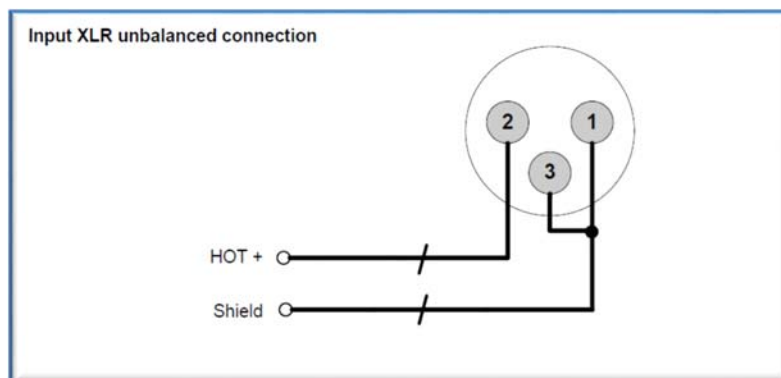

Amplifier Output Connections

The iK42 amplifier is fitted with one Speakon™ connector per amplifier channel. The appropriate conductor terminations are shown below and on the rear panel of the unit.

Amplifier output connections – iK42

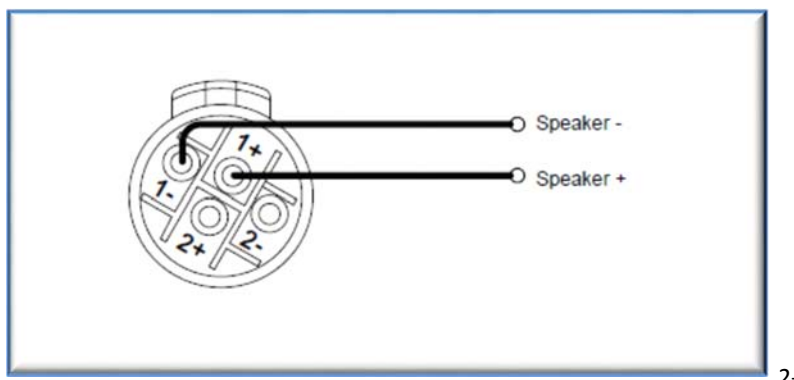

2-

Additionally, the channel 2 output is duplicated on the Speakon™ connector for amplifier channel 1 for Bi-Amp wiring. Similarly, the channel 4 output is duplicated on the Speakon™ connector for amplifier channel 3. This can be useful for making a connection to two loudspeakers with one 4-core cable (i.e. Bi-Amp).

On the iK81 model, all outputs are Bi-Amp; each Speakon™ connector carries two amplifier outputs – Channels 1&2, Channels 3&4, Channels 5&6 and Channels 7&8.

Amplifier output connections – iK81 and Bi Amp

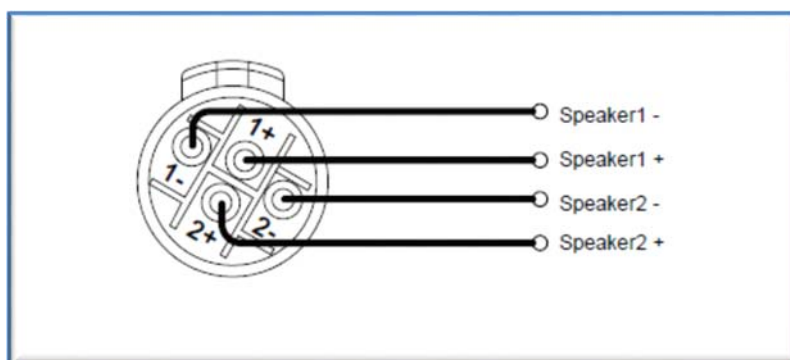

In addition, the channel 1 or channel 3 connector (all the Speakon™ connectors on the iK81 model) can also be used if the pair of amplifier channels is being operated in bridged mode.

Amplifier output connections – Bridge

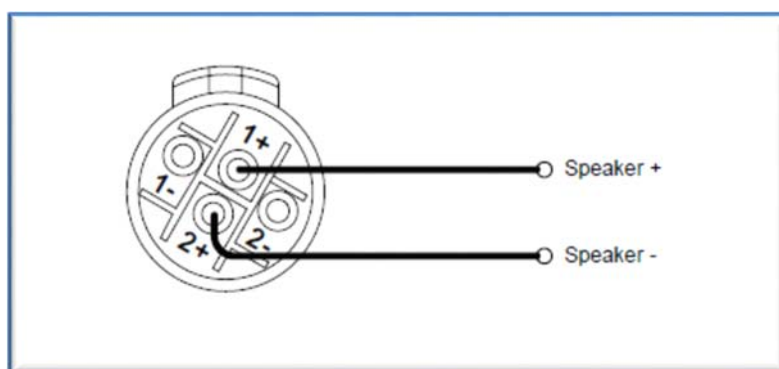

More than one speaker can be connected to each channel provided the total impedance per channel is not less than **2 ohms**. In bridged mode the minimum total impedance should not be less than **4 ohms**.



Load Matching

Each output of the device can be optimised to drive either a low impedance load (e.g. 2, 4 or 8 Ohms), or a Constant Voltage (C.V.) using the Load parameter in the Output menu. There are several C.V. settings (25V, 70V and 100V Line) which determine the maximum RMS voltage that the amplifier will produce. Select the one which is appropriate for the installation. A number of low impedance settings (depending on the model) are also available. Although it is not critical that this setting matches the impedance of the connected load, this will maximise the power that is available for the load.

Panel Layouts

(The iK42 is illustrated. The iK81 is similar, but with double the quantity of output indicators and mute buttons)

1. Power Switch- Applies mains power to the device. If the device has entered Sleep mode, it may be woken up again either from the Vu-Net application, or by switching this switch off, then on again.

2. Graphical Display- This will show the Home screen; a useful overview of channel allocation. On most pages the currently selected channel and parameter information is displayed on the upper part of the screen and the parameter value on the lower part of the screen. The screen contrast can be changed by pressing the <UTILITY> button to navigate to “Screen” and using the encoders to change the percentage; this can also optimise the viewing angle.

3. Status Indicators- The “OVERLAY” indicator shows when there are parameters active on a group layer, which the user cannot access through the front panel of the device (see Overlay Flush). The “DANTE” indicator shows that a Dante network feed is routed. The “ONLINE” indicator has three states: Off – the unit is offline and not connected to a computer or network. Flashing- the unit is searching for an IP address; if the unit does not find an IP address the unit will assign itself an IP address automatically and the indicator will stop flashing. On- the unit is online and connected with software. IP settings can be viewed or changed within the <UTILITY> pages. The “AES3 IN” indicator illuminates when one or more of the inputs is using an AES3 source.

4. Parameter Encoders- Two velocity sensitive parameter encoders are used to adjust parameters shown on the display. Up to three parameters at a time are displayed on the screen. The parameter name is shown above the parameter value in each of the three screen sections. Use SELECT to highlight the parameter, then ADJUST to change it.

5. Page Selection Buttons- When one of the buttons <INPUT>, <OUTPUT> or <UTILITY> is illuminated, the up <↑> and down <↓> arrows will also illuminate, informing the user that these buttons may be used to scroll through the various pages of parameters that may be viewed and edited. The <ENTER> button is used to confirm an operation such as storing or recalling a preset or snapshot. It will illuminate when the user is being invited to press it. It will flash when warning the user that pressing this button will activate an important function.

6. Menu Buttons- There are three buttons to determine which section of the device to view or edit. The <OUTPUT> button displays pages of parameters associated with a particular output channel. The <INPUT> button displays pages of parameters associated with a particular input socket or input DSP channel. Pressing <INPUT> or <OUTPUT> buttons repeatedly will scroll through the inputs/outputs of the device. After the last channel, navigation returns to the Home screen. The <UTILITY> button displays pages of miscellaneous parameters not associated with any particular channel. Whilst in Edit mode, one of these three buttons will be illuminated. They are mutually exclusive – pressing one of the buttons will deselect any others that are active. Pressing Utility will escape back to the Home screen.

7. Input Signal Indicators- A set of five indicators show “Sig”, “-12”, “0dBu”, “+6” and “+12” and “Clip (mute)” for each of the DSP inputs “A” “B” “C” “D”.

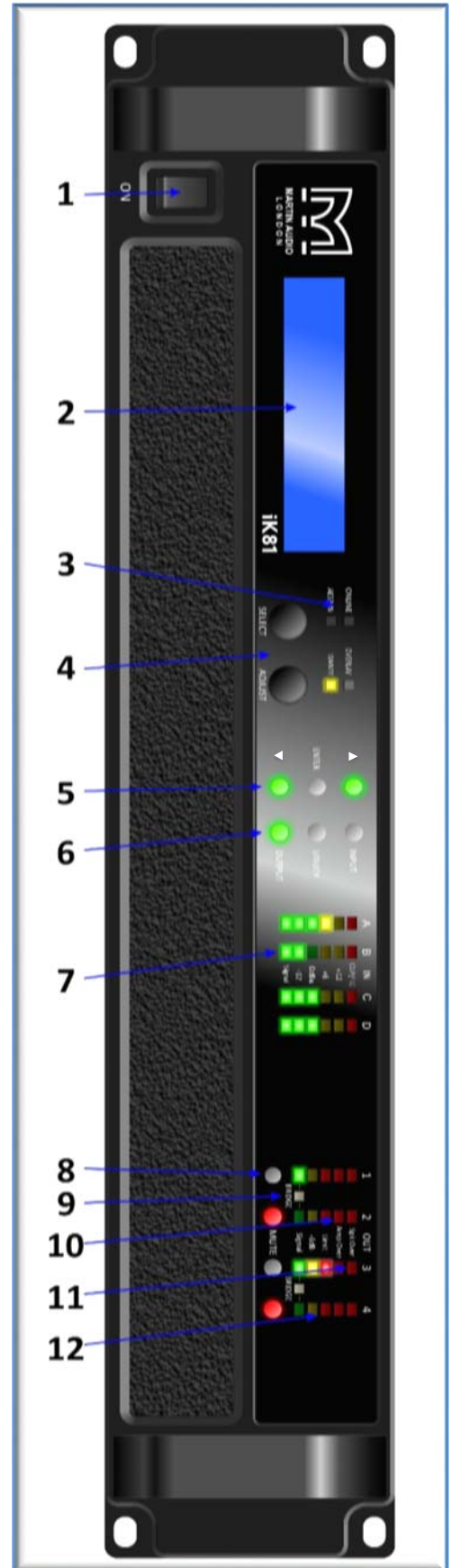



The signal present Indicators operate at approximately -40 dBu. The Clip/mute Indicators warn the user of input overload and operate at 1dB before clip. This indicator also shows a muted input

8. Mute Buttons- DSP output mute status is indicated and controlled by an illuminated button for each channel. These flash when the entire unit is muted from the AUX port or from Vu-Net Mute-All, or if this channel has been muted by the protection systems.

9. Bridge Indicator- This will illuminate when the channel pair is in Bridge mode. The controls for the left channel of the pair will determine the settings. See Bridge Mode

10. Amplifier Indicator- This indicates when the amplifier protection systems are reducing the gain to keep the parameters of the amplifier within specification, or when that the channel is clipping.

11. Driver Indicator- This indicates a signal 6dB higher than the limiter threshold, or when the threshold of the excursion limiter has been exceeded, or when the thermal limiter is active. Please note that because of the long release time of the thermal limiter, this indicator may remain illuminated for several seconds after signal on that channel is reduced.

12. Limiter Indicators- The output indicators shows the status of the limiter and output level. The level indicated is that before the limiter, referenced to the limiter threshold. The <SIG> indicator shows when a signal is present on the output. The second indicator <-6dB> shows that the signal has reached 6dB below the limiter threshold. The third <LIMIT> indicator indicates that the threshold of that output channel has been reached.

1. Loudspeaker Connectors (iK81). The amplifier Speakon™ outputs. Connect the first loudspeaker to the 1+ and 1- terminals and the second loudspeaker to the 2+ and 2- terminals. For Bridged mode, use terminals 1+ and 2+.

2. Loudspeaker Connectors (iK42). The amplifier Speakon™ outputs. Connect the loudspeaker to the 1+ and 1- terminals. CH1 also carries the (duplicated) loudspeaker output for channel 2 on terminals 2+ and 2-. Similarly, CH3 carries the loudspeaker output for channel 4 on terminals 2+ and 2-. For Bridged mode, use terminals 1+ and 2+ of either CH1 or CH3.

3. Analogue Audio Link Connectors- Carries a duplicate (parallel) connection (to another amplifier for example).

4. Analogue Audio Input Connectors- All audio connections are fully balanced and wired: pin-1 to ground (as required by the AES48 standard), pin-2 hot & pin-3 cold.

5. AES3 Audio Input Connectors- For inputting Digital Audio signals. The Input is fully balanced and wired: pin-1 to ground, pin-2 data+ & pin-3 data. The Link connector allows a buffered AES3 signal to be passed on to another device.

6. Dante Ports- Connection ports for Dante™ with the Primary and Secondary port convention available.

7. Ethernet Communications Port- The amplifier may be controlled entirely using Martin audio's Vu-Net software and so can integrate easily with other products that are supported on the same platform such as the Multicellular range, CDD-Live, DD12 and PSX. Connection will normally be made via this Ethernet port connector. This port is also used for updating the firmware in the unit.

8. Auxiliary Port- The auxiliary port may be configured to recall snapshots or apply muting.

9. Power Inlet- The unit should be connected to a suitable mains electricity supply using an earthed 32 amp PowerCon connection power lead. The device has a switch mode power supply that is capable of operating with a nominal mains voltage of 100V to 230V, 50/60Hz without re-configuration.

NOTE: The device must be earthed to a suitable power earth; failure to do so may affect performance and/or operation and will invalidate warranty and could be potentially hazardous.

10. Relay output- This isolated relay output may be used to indicate abnormal conditions to external monitoring apparatus. See Fault Relay

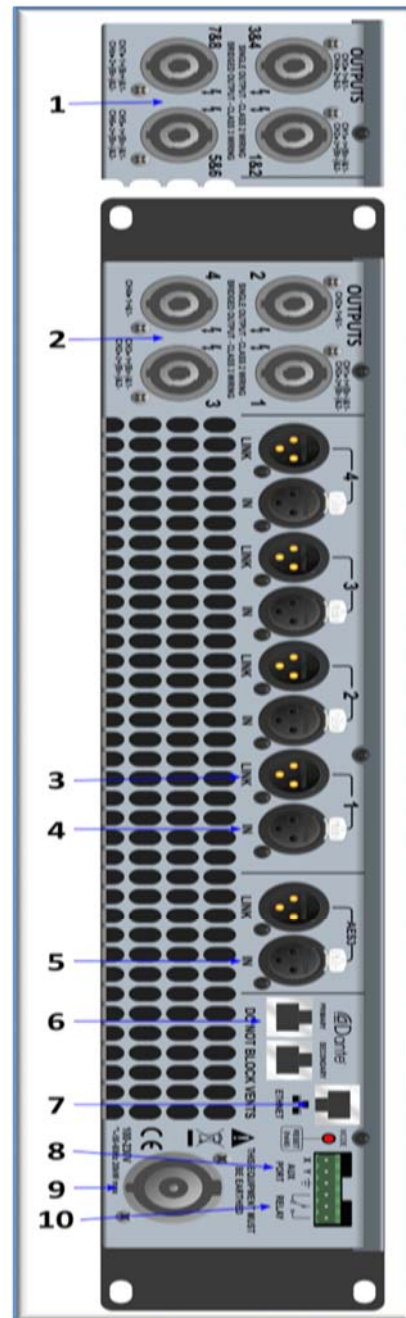

Quick start

The iK81 and iK42 are not only powerful amplifiers but have extremely comprehensive processing ability allowing complex systems to be designed to suit any application for many applications however, all you need to do is recall the appropriate Preset, connect your speakers and source and away you go. This section shows you how to achieve the quickest, most straightforward set up using an iK42.

Loading XE500 (or XE300 Bi-amp) Presets

1. Connect the amplifier. The iK42 requires mains connected to its 32Amp PowerCon inlet, an input feed, either balanced analogue to the input XLRs, AES3 to the dedicated AES XLR, or Dante to the Dante RJ45 port. XE500 and any of the other monitors run in bi-amp mode can be connected directly to output Speakon 1 and 3 as these also have channels 2 and 4 respectively connected to pins 2+/- specifically for bi-amp operations. See the chapters on mains, input and output connections for more details.
2. Power up the amplifier, once it has completed its power-up cycle press "Input" and press the down arrow once to show the Preset recall for Channel A-



3. Use the Adjust control to scroll round to the required XE500 Preset;-



4. Press "Enter" you will see the following message;-

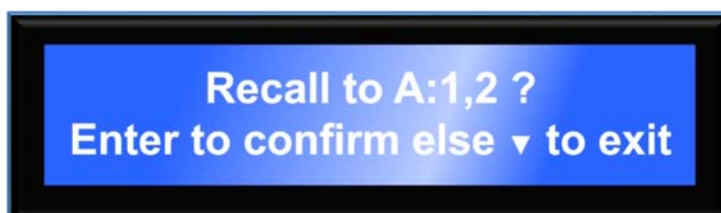

5. The Enter button will be flashing, press it and you will see the following;-



6. Input A will now feed output 1 with the XE500 LF Parameters and output 3 with XE500 HF parameters. Press "Input" again;-



7. You will notice that the screen is now showing the preset for input B. Again using the Adjust control select the XE500 preset and press "Enter";-

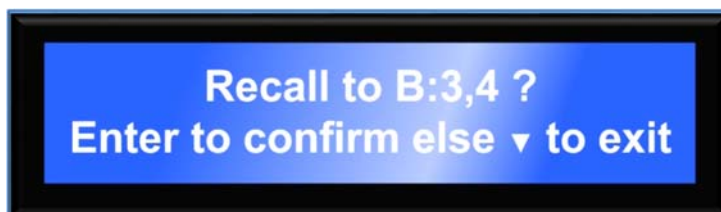

8. Press "Enter" and the preset loading is complete, press "Utility" to escape back to the default screen;-



This shows that DSP A and B are both loaded with the XE500 preset. Input 1 is routed to output 1&2, input 2 is routed to outputs 3&4, inputs 3 and 4 are not used therefore not routed anywhere. The amplifier is ready for use.

Loading XE300 Passive Presets

Loading presets for passive monitors is exactly the same procedure other than it being necessary to define the preset for all four Inputs.

- Connect the amplifier. The iK42 requires mains connected to its 32Amp PowerCon inlet, an input feed, either balanced analogue to the input XLRs, AES3 to the dedicated AES XLR, or Dante to the Dante RJ45 port. XE300 in passive mode can be connected directly to output Speakons 1, 2, 3 and 4. See the chapters on mains, input and output connections for more details.
- Power up the amplifier, once it has completed its power-up cycle press "Input" and press the down arrow once to show the Preset recall for Channel A-



- Use the Adjust control to scroll round to the required XE300 Preset;-



- Press "Enter" and you will see the following screen;

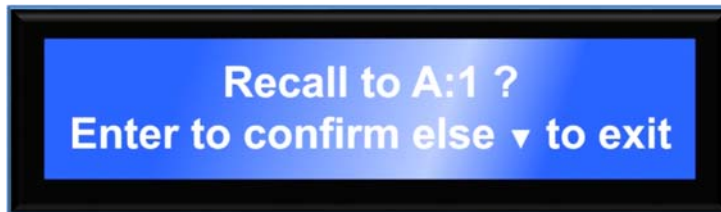

- Press "Enter" again you will see this screen;-

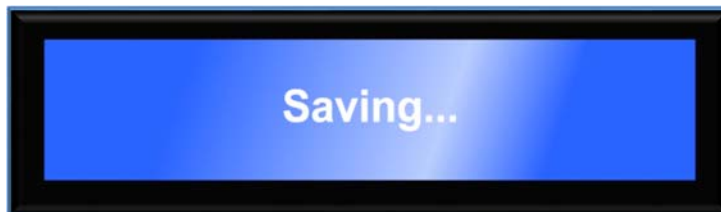

- Press "Input" again and you will see the Recal Preset Screen for input B;-



- Repeat the previous process, scroll the Adjust knob to select the XE300 passive preset, press "Enter" twice to confirm. When the preset is loaded press "Input" again to load the same preset into input C and repeat, finally press "Input" once more to enter the preset into input D. Press "Utility" to return to the home screen;-



This shows that DSP A, B C and D are loaded with the XE300 Passive Preset, Input 1 is routed to Output 1, Input 2 to Output 2 and so on. The amplifier is ready to use.

Operation

Starting up the unit

When power switch is switched on the unit will go through its start-up cycle, checking all the sub-systems as it does so. Along the way, the screen will inform you of its progress. Once this is complete the display will then show the Home screen indicating drive module configurations.

Overview of Modules, Presets Components and Snapshots

A *Drive Module* represents a loudspeaker subsystem (e.g. Sub and full range), and comprises one input channel and a number of output channels, associated with one-another by routing. The size of the Drive module is determined by the number of outputs in it. The device may contain up to four Modules.

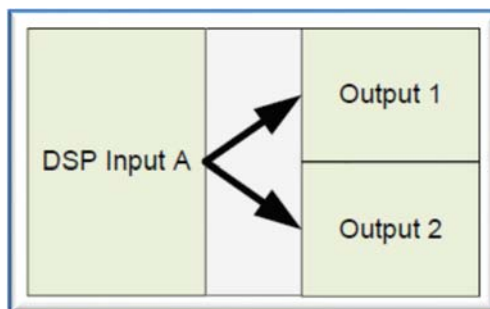

A *Module Preset* is a collection of settings (parameters) for a Drive Module of a particular size. The Preset contains a set of parameters for one input and a set of parameters for each of the outputs in the module. The most obvious example would be a bi-amp system, either individual cabinets such as a BlacklineX sub used with one of the full range cabinets, or a bi-amp speaker such as the XE500 monitor.

When a Module Preset is recalled, it will automatically change the routing between Input DSPs and Outputs, consuming a number of outputs according to the size of the Drive Module. Recalling a Module Preset thus always creates a Drive Module with consecutive outputs.

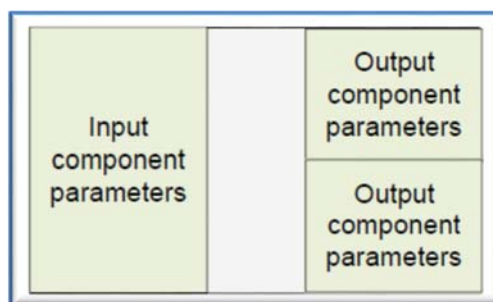

A *Component* is a collection of settings (parameters) for one (input or output) channel. Any one of the output components in a Module Preset may be recalled to any individual output.

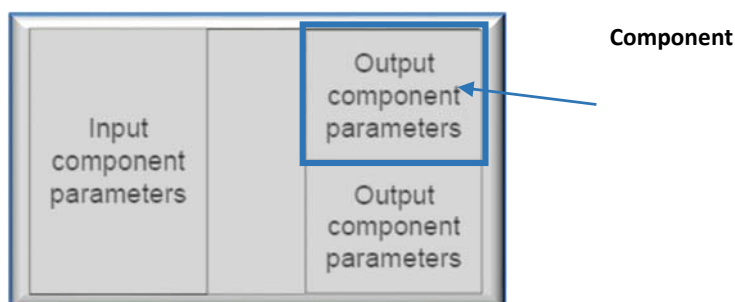

A *Snapshot* is a device-wide representation of most of the settings in the device. This is represented as four Input Component numbers, four Output Component numbers, plus a number of machine-centric settings such as routing and Input/Output Analogue/Digital selection etc.

Device Settings	Input A component number	Output 1 component number
	Input B component number	Output 2 component number
	Input C component number	Output 3 component number
	Input D component number	Output 4 component number

Navigation

Parameter navigation and adjustment on the iK42/iK81 Series is very straightforward. There is no concept of drilling down deeper into hidden menus; every parameter is accessible by simply scrolling across a 'map' of parameter pages which can be thought of as placed on a 2-dimensional grid. Horizontally across the width of the grid are the various channels, and vertically up and down the grid are the parameter pages for each section of processing.

To view a parameter, repeatedly press the desired <INPUT> or <OUTPUT> channel button until the desired channel is reached., Then repeatedly press the up <▲> and down <▼> buttons to scroll through the processing parameters for the selected input/output. For example, to adjust the first band of parametric EQ on input C, press 'Input' three times, 'C' will be displayed on the left of the LCD window. Then press 'Up' 5 times. The display will scroll from Gain to Delay, High pass filter, two low shelf filters before arriving at the first parametric which may now be edited using the select and adjust controls.

Two encoders allow you to select and adjust a parameter. Often, several parameters will be shown in various zones on the display. To select a parameter for adjustment, turn the left-most encoder such that the parameter you wish to adjust is highlighted. Then turn the right-most encoder to adjust the value of that parameter. Turning this encoder clockwise will increase the value of a parameter, or anticlockwise will decrease it. The encoders are velocity-sensitive so turning an encoder rapidly will cause the action to 'accelerate', so the value changes more rapidly.



Turn the SELECT encoder to highlight the zone you wish to adjust.

Turn the ADJUST encoder to change its value.

The Home Page

The Home Page presents an overview of the configuration of the device. It indicates the user-define Device Name at the top, and shows the four Drive Modules. In each Drive Module the top line shows the Input DSP channel ('A', 'B' etc), and the name the user has given to this channel. The bottom line shows the physical input number, and a list of the outputs which are routed from the Drive Module.

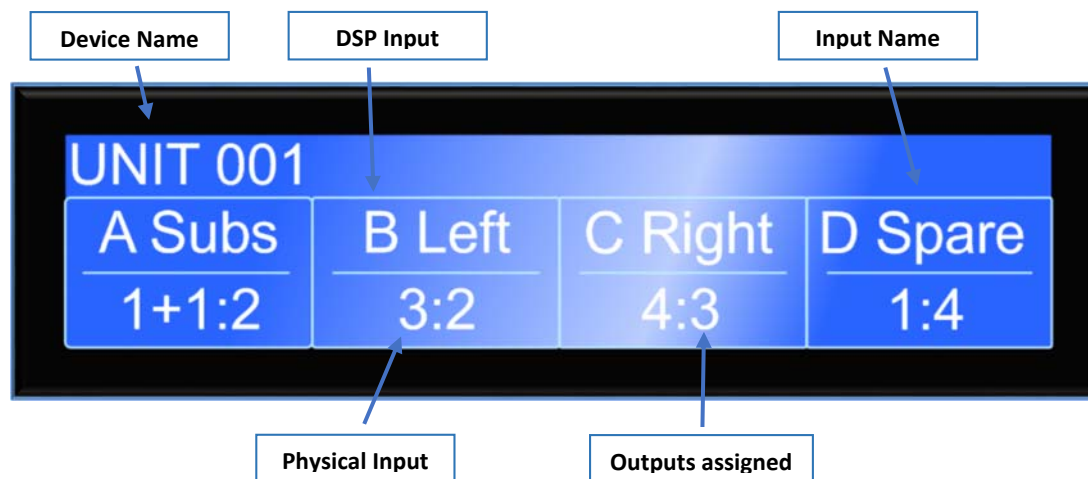

Drive Modules

The iK42/iK81 Series uses Drive Modules to represent loudspeaker sub-systems. Drive modules result in a less processor-centric and more speaker-orientated system design. A drive module is defined as the processing provided by one Input DSP, and a number of outputs, which are associated with one-another by means of routing. For example, if Input DSP B is routed to outputs 3 and 4, then this is a 2-way Drive Module; input DSP B forming the 'master' control, and output DSP 3 and 4 providing the driver-related control. The Input DSP parameters then control the Drive Module (and thus the speaker sub-system). The Drive Module control panel in the Vu-Net application is then used for control and monitoring of this sub-system.

Drive Module Presets

Presets do *not* change the settings device-wide. Rather, recalling a Module Preset creates a Drive Module by 'consuming' a number of consecutive outputs and setting up routing between the Input the preset was recalled on and those outputs. The parameters in that Drive Module are then set according to the parameters in the components in the Module Preset.

Note however, that modules with non-consecutive outputs can be created by manually manipulating the routing, and then recalling Component Presets to the individual outputs. The resulting system can then be stored in a Snapshot. Such a Module cannot be saved in a Module Preset.

Note: When a Module Preset Recall consumes outputs to construct a module, it treats a pair of Bridged outputs as a single channel, so recalling a 2-way Module Preset will consume 3 output channels if a Bridged pair is encountered. See Bridge Mode

Note: DSP inputs are not the same as physical inputs. The iK42/iK81 Series has four audio inputs and four DSP inputs. This is a matrix mixing system where any physical inputs, be they analogue, AES3 or networked audio feeds, can drive any number of DSP inputs.

Component Presets

A Component Preset represents the processing for just one output. Any part of a Module Preset may be recalled to any one output. A Drive Module comprised of parameters which have been recalled to its outputs using Component Preset Recalls can then be saved into another Module Preset provided the outputs remain consecutive (i.e. you have not changed the routing manually). If the routing has been changed manually, then the whole arrangement may be saved into a Snapshot. See also Snapshots and Recalling Components.

Factory Module Presets

The device will contain a library of Factory Presets designed to suit a range of enclosures.

Factory Presets may contain some parameters that are fixed and hidden from view; the remainder of the parameters are available for user manipulation. The number and type of hidden parameters is dependent on the Factory Preset, typically

crossover frequencies, output delay and some EQs are hidden; those settings that are a function of the loudspeaker cabinet design and should not require adjustment for different applications. Factory Presets are locked (as indicated by a 'box' symbol after the Preset name) so they cannot be overwritten. The user can, however, store an edited version of a Factory Preset in any free preset location.

In addition to the Factory Presets the device may have further 'Skeleton Presets' which will help to create new presets. They can be used to develop settings for any loudspeaker combination and are recalled in the same way as the Factory Presets described above. These Presets are also usually locked but the user can name and store their own edited versions in any free preset location.

Storing Module Presets

Once a drive module has been created it can be stored by pressing the <INPUT> button until the edited channel is reached, then pressing the down <▼> button until store page is reached. Using "ADJUST" encoder will change the preset number. When the destination preset is reached, pressing the <ENTER> button will enable the name associated with that preset to be changed. Once the name changing is active, the character to be changed will be highlighted and the "ADJUST" encoder will edit the character. Using the "SELECT" encoder will move through the character positions. Once the new preset name has been assembled, the operation can be confirmed by pressing the <ENTER> button, then a message will be displayed, "Enter to confirm or ▼ to exit"; pressing <ENTER> will store the preset.



Note: Storing a Drive Module preset for a module which is not configured with consecutive outputs is not permitted.

Note: When storing a Drive Module preset on the device, Component Names cannot be edited. To change Component names, the Module Preset must be saved in Vu-Net.

Recalling Module Presets

To recall a Drive Module preset, press the <INPUT> button, then use the down <▼> button navigate to the RECL Preset page. Using the "ADJUST" encoder will scroll through the presets available. When the desired preset is reached, pressing <ENTER> will display the message "Enter to confirm or ▼ to exit", pressing <ENTER> will recall the preset. Note that presets do not contain and do not disturb parameter Overlays. (See Overlays)



Recalling Components

To recall a Component Preset (to a single output), press the <OUTPUT> button, then use the down <▼> button navigate to the RECL Preset page. Using the encoder, "A" will scroll through the component presets available (as indicated by the ModulePreset.Component number and ModulePreset.Component name). When the desired component is reached, pressing <ENTER> will flash the Enter button. Pressing <ENTER> again will then recall the component preset. Note that component presets do not contain and do not disturb parameter Overlays. (See Overlays)



See also *Snapshots*.

Input

AES3 Inputs

In addition to the usual analogue inputs, the Device can also accept AES3 digital inputs. When a DSP input channel is assigned to an AES3 channel, the “AES3” indicator will illuminate.

There is no ‘standard’ for the relative gains between Analogue and AES3 so depending on the levels delivered by the audio source, it may be necessary to adjust the digital input gain trims to normalise them. It is possible to adjust the gain of the AES3 input using the Input Trim AES3 Gain parameter. For example, to achieve 0dBFS = +18dBu, set the AES3 trim to -2dB. To achieve 0dBFS = +24dBu, set the trim to +4dB.

This device will automatically lock onto any sample rate within the range 28kHz and 108kHz.

Dante™ Inputs

Using the Dante input, it is possible to select any channel(s) as being sourced from this network. To do this, connect the audio network connection to the connection on the rear of the Device, and set the relevant Input Type menu Type parameter to “Dante”.

When the Dante has been selected as part of the input routing, the “Dante” indicator above the encoders will illuminate. This indicator will come on even if there are no cables plugged into the networked audio port on the Device.

As for the AES3 inputs, it is possible to set the relative gain between an Analogue input and the signals sourced from the Dante using the Input Trim Dante gain parameter.

The amplifier will automatically select the correct sample rate from the incoming stream.

For other details on the operation of the Dante, please refer to the relevant manufacturer’s documentation.

Automatic Input Selection (Fallover)

It is possible to configure the input selection to be automated. The Input TYPE screen has a Fallover parameter, which defaults to Manual, allowing you to select what Type of input you wish to use. When Fallover AES3>Analogue is selected (on an input channel which supports AES3), then the AES3 source will be automatically selected if it has a valid audio stream on it. If the AES3 stream should fail, then Analogue is automatically selected instead.

When Fallover Dante>Analogue is selected (when the Dante option is fitted), then the Dante source will be automatically selected if it has a valid audio stream on it. If the Dante stream should fail, then Analogue is automatically selected instead.

Similarly, it is possible to select Fallover Dante>AES3 on a channel that supports AES3 and Dante is present.

The ‘Auto’ setting allows the highest priority input source that is active to be automatically selected, so the user could just plug a source into any input and it will be automatically selected. The priorities are: Dante first, AES3 second, Analogue third.

Note that any automatic selection will take precedence over manual selection, so if you try to manually select Dante when there is no valid Dante stream, then it will revert to the Fallover input source.

Gain and Polarity

The gain page of the input channel selected allows users to increase or decrease the amount of signal going into the selected input. Using the “SELECT” encoder to highlight the Gain value allows the value to be changed by the “ADJUST encoder in 0.2dB



steps from -40dB to +20dB. The presence of an active Group Overlay parameter is indicated by the '[' symbol (See Overlays). This page will also allow users to change the polarity of the selected input from normal to reverse and to mute the selected channel.

Delay

The delay page which controls the amount of delay associated with the input channel selected and is adjustable from 0 to 998ms. The delay parameter is adjustable in fine steps at low values; the adjustment becomes progressively coarser as the value increases. The presence of an active Group Overlay parameter is indicated by the '[' symbol. See Overlays.

High Pass Filter

System high pass filtering is provided for the input signal. Filter type is selectable from 1st order, Butterworth, Bessel, Linkwitz-Riley and Hardman. Filter slopes of up to 4th order or 24dB / octave are provided. Not all filter types are available in all slopes. For example 18dB / octave Linkwitz-Riley filters do not exist.

The Hardman type filter is always described by its order as the filter becomes progressively steeper rather than following a linear slope so a dB/octave description is not accurate.

Parametric Equalisation

There are nine stages of equalisation available for each input channel, three shelving filters and six parametric filters.

FIR Shelving EQ

The Input High Shelf EQ is implemented using a Finite Impulse Response (FIR) filter, and exhibits a linear phase response; that is all frequencies are delayed by the same amount. This can be important in applications where different amounts of EQ are applied to different parts of a speaker cluster, such as to add 'Throw' EQ boost so that parts of cluster which are throwing further can have HF absorption correction added. If this EQ is not linear phase, then the zones where the speakers combine may suffer frequency response anomalies. Being a linear phase FIR equaliser, this necessarily introduces some latency delay, which is constant regardless of the settings. However, when the 'Enable' parameter is set to "Off", it is removed from the signal path entirely, so it does not add any latency. In this page you can change the frequency parameter from 2kHz to 20kHz, enable/disable the filter, and change the cut or boost in 0.2dB increments. The presence of an active Group Overlay parameter is indicated by the '[' symbol being appended to the Gain value (See Overlays). The filter (and its associated latency) can be completely removed by setting the enable parameter to the "Off" position. Note that this EQ can only be used in Module Groups if set to 'On'.

See also Latency Delay.

Parametric Filters

Parametric filters are defined by frequency, bandwidth and gain. The frequency is adjustable over the range from 10Hz to 25.6kHz. The bandwidth shown as Width on the screen, ranges from 0.10 octaves to 5.2 octaves. Bandwidth can be shown and adjusted as Q or Octaves (Oct). Gain is adjusted in 0.2dB increments. The presence of an active Group Overlay parameter is indicated by the '[' symbol being appended to the Gain value. (See Overlays).

See also Bandwidth Units in Utilities.

Routing

Routing allows users to route any physical analogue or digital signal channel to any DSP input. This is effectively a matrix mixing system where all DSPs can be driven from any one input, or from pairs of inputs "1+2", "3+4", "1+3", "1+4", "2+3" or "2+4". Summed inputs have 6dB of attenuation so that a sum of largely similar programme material remains at the correct calibrated level.

Output

Gain and Polarity

The gain page of the output channel allows users to increase or decrease the relative signal gain for the selected output. The Gain value may be adjusted in 0.2dB steps from -40dB to +20dB. This page will also allow users to change the polarity of the selected output from normal to reverse.

Delay

The delay page controls the amount of delay associated with the output channel selected and is adjustable from 0 to 998ms. The delay parameter is adjustable in fine steps at low values; the adjustment becomes progressively coarser as the value increases.

High and Low pass Filters

High pass and low pass crossover filtering is provided for the output signal. Filter type is selectable from 1st order, Butterworth, Bessel, Linkwitz-Riley, Hardman and LIR Linear Phase. Filter slopes of up to 8th order or 48dB / octave are provided. Not all filter types are available in all slopes. For example 18dB / octave Linkwitz-Riley filters cannot be selected because they do not exist.

The Hardman type filter is always described by its order as the filter becomes progressively steeper rather than following a linear slope so a dB/octave description is not accurate.

LIR Crossover Filtering

Unique to Martin Audio, "Linear Impulse Response" (LIR) crossover filtering gives a Linear Phase crossover which has a constant delay regardless of frequency (unlike other types of crossover which delay different frequencies to a different extent, thus smearing the arrival time). The LIR crossover can thus be described as having a flat Group Delay response, and thus entirely free of Group Delay Distortion, this is exactly the same as can be provided by common FIR filtering but without the complications and disadvantages inherent with the FIR technique.

The shape of the LIR crossover filter is similar to a 4th order Linkwitz-Riley filter, and maintains zero phase difference between the adjacent bands across the crossover region to keep the polar response rock steady.

Note that very narrow bandwidths are not possible with this crossover type. If the Low Pass frequency is too close to the High Pass frequency, then the filter will 'mute'.

Linear Phase filtering necessarily introduces delay; the laws of physics demand it. To keep this delay to a minimum, it is recommended that more conventional crossover shapes (such as Linkwitz-Riley) are used for the very lowest frequency high-pass edge, particularly if this is less than perhaps 100Hz, which is well below the frequency thought to cause audible 'Group Delay Distortion'.

This constant delay will depend on the lowest high-pass frequency used in the crossover filters in a given Drive Module.

See also the section on Latency Delays.

Parametric Equalisation

There are ten different EQ filters; two shelving filters and eight parametric filters. Parametric filters are defined by frequency, bandwidth and gain. The frequency is controlled over the range from 10Hz to 25.6 kHz. The bandwidth, shown as Width on the screen, ranges from 0.10 octaves to 5.2 octaves. Bandwidth can be shown and adjusted as Quality Factor or (Q), or Octaves (Oct). Gain is adjustable in 0.2dB increments.

See also Bandwidth Units in Utilities.

Limiters

The iK42/iK81 Series includes three limiters in the output signal path. Please note that whilst the Limiters in this product offer protection for amplifiers and drivers, they can never protect from all possible scenarios, therefore Martin Audio is not responsible for any damage which might occur.

VX Limiter

This is a peak-detecting signal limiter. The VX Mode parameter determines the style of limiter. When Virtual Crossover (VX) mode is off, the limiter is controlled in a conventional manner; the only controls being Threshold and Overshoot.



The Overshoot limiter prevents the signal from exceeding threshold during the attack phase of the main limiter by more than a predetermined amount. The optimal Overshoot setting is usually about 8dB. Lower Overshoot settings will sound progressively 'harder'.

When VX mode is engaged, the user can choose the crossover point of a 'virtual crossover', which incorporates two limiters per output so the user can individually limit the drivers in a passive 2-way enclosure using individual thresholds, and optimised attack and release characteristics for each. The Threshold of the second 'Hi' limiter is set relative to the threshold of the first 'Lo' limiter.

This Limiter introduces some delay. In non-VX mode, this delay will depend on the lowest high-pass frequency used in the crossover filters in a given Drive Module. In VX mode, the delay is related to the Split frequency. This delay will be applied to all of the outputs in a given Drive Module to keep them in phase.

See also Latency Delays

Tmax Thermal Limiter

The Thermal Limiter is intended to protect the driver against damage due to over-heating. It models the temperature of the driver, and constrains the output signal level in order to keep the average output power below a predetermined limit, applying attack and release characteristics to go some way towards modelling the complex thermal circuit of a driver's voice coil and magnet assembly.

Three parameters are available for adjustment:

Threshold – the continuous RMS voltage which the driver should be able to withstand. This is calibrated at the output of the amplifier. The Thermal Limiter can be defeated by setting the Threshold to the maximum "Off" value.

Attack – The time-constant of the speed at which the driver heats up (in seconds).

Release – The time-constant of the speed at which the driver cools down (expressed as a multiple of the Attack time).

Xmax Excursion Limiter

The Excursion Limiter protects the driver against excessive linear movement of the cone and voice-coil which could otherwise cause mechanical damage. Since this movement (excursion) is largely related to the inverse of the signal frequency, drivers are prone to being damaged by very low frequencies. This limiter is progressively more sensitive at lower frequencies and, rather than varying the gain to provide the limiting action, it uses a sliding high-pass filter to progressively curtail the low-frequency response, effectively limiting the linear excursion to below the X-max specification of the driver.

To set the limiter up, it is necessary to know the shape of the family of Excursion vs. Frequency curves of the driver for various drive voltage levels. A curve should then be chosen where the slope is high where it passes through the specified X-Max value for the driver. The peak voltage and frequency of this point should then be noted.

The Xmax limiter is usually then set up using just two parameters:

Threshold – the peak voltage of the point arrived at above. This is calibrated at the output of the amplifier. The Excursion Limiter can be defeated by setting Threshold to the maximum "Off" value.

Frequency – The frequency at which the above threshold voltage is appropriate.

A further parameter "*Min*" may also be available for more advanced applications. This allows the increasing limiting action at lower frequencies to level-off below a certain frequency. In most application, this would be left set to its default value of 5Hz.

Bridge

When an amplifier pair is set to Bridge Mode, it uses two amplifier channels to drive one loudspeaker with greater power. In this mode, only one set of Output controls is active per pair of amplifier channels since both of the amplifiers in the pair are driven with the same signals, as determined by the left-hand (lower numbered) channel of the pair controls. Bridge settings should be set up before recalling Drive Module Presets. Module Preset Recall will see a bridged pair of outputs as a single channel. Bridge Mode is enabled or disabled in the AMP page for a given odd numbered Output. When enabled, the Bridge indicator will be illuminated between the bridged channels. When Bridged, the partner (even numbered) channel will not show any signal on the limiter meter, and the Mute button will not operate, neither will you be able access any of its parameters for adjustment. The Amplifier protection indicator however will still operate. Note that the gain of a bridged pair of channels will be 6dB higher than



a single channel so 38dB. This may impact on limiter settings and balance of levels in a system where some amplifier channels are bridged and others are in standard mode.

Routing

Outputs can be driven from any DSP input. This routing is the fundamental means by which Drive Modules are created. Routing should always consume outputs consecutively alphabetically and numerically. However, non-consecutive Drive Modules may be created using manual routing and Recalling Components. See the drive module section of this user manual for more information.

Driver

The optimal drive level may be adjusted for a given driver impedance using the Load parameter. (See Load Matching). The live measured impedance value is also shown on the Driver page. Since the device can only measure this when there is a signal, the impedance is indicated as “?” when there is insufficient signal level to perform a measurement.



Utility Pages

Screen Contrast

The Screen page in the “UTILITY” section adjusts the contrast (and optimal viewing angle) of the screen from 0-100% in 1% increments.

Stereo Linking

Stereo linking is available between DSP Drive Modules A & B and between C & D. Changing a parameter in either of the stereo linked Drive Modules will change the other linked Drive Module. Stereo linking is controlled by the STEREO page in the “UTILITY” menu.

Note: Stereo linking will only work when the linked Drive Modules are of equal size. Note: Stereo Linking state is not stored in Presets (but is stored in Snapshots)

Current Ethernet IP Address

This may be viewed in the “IP Curr” page of the “UTILITY” menu. This value cannot be edited.

IP Mode

The Ethernet IP address may be automatic “Auto” or may be a fixed static value “Static” as determined by the “IP Mode” page of the “UTILITY” menu.

WARNING – Do NOT use Static mode unless your IT system specifically requires it. Auto mode should always be used where possible since in this mode, the Device can always be ‘discovered’ by the Vu-Net application. When in Static mode, the IP Address will flash on the Home screen.

See also *Ethernet Configurations*.

IP Static

This allows the Static Ethernet IP address to be adjusted by the rotary encoders on the IP Static page of the “UTILITY” menu. This page will only be visible when in Static mode.

Store Snapshot

This page of the “UTILITY” menu allows a Snapshot of the device to be stored.

See also *Snapshots*.

Recall Snapshot

This page of the “UTILITY” menu allows a Snapshot to be recalled.

See also *Snapshots and Aux Port*.

Bandwidth Units

This page of the “UTILITY” menu allows the Bandwidth of Parametric Equalisers to be viewed and adjusted in either Octaves or ‘Q’.

Aux Style

This page of the “UTILITY” menu allows the action of the Aux port to be viewed and adjusted.

See also *Aux Port*.

ECO

This page of the “UTILITY” menu allows the device to save power by going into a low power mode when it is not being used. Standby is a fast mode which saves some energy, but will wake-up very quickly if an audio input is detected. The associated Standby Time parameter allows the amplifier to automatically go into power-save if no audio signal has been detected for a period of time. This function can be defeated by setting the latter control to Manual. Linea would strongly advise leaving it set to automatic however as there is no negative consequence to doing this since ‘wake-up’ on detecting the presence of an audio input signal is instantaneous.



The Standby Now 'parameter' allows the amplifier to be put into standby mode manually when it is not being used.

Sleep is a deep power save mode which saves the most energy, however it will take a small number of seconds for the amplifier to wake-up, and it may only be woken up manually (either from the Vu-Net application or by switching the device off then on again). The associated Sleep Time parameter allows the amplifier to automatically go into Sleep mode if no audio signal has been detected for a period of time. This function can be defeated by setting the latter control to Manual.

External Breaker Protection (EBP)

The Power ("PWR") utility page provides access to the External Breaker Protection (EBP) feature, which allows the output power to be limited in order to prevent the nuisance tripping of mains circuit breakers or fuses when the amplifier needs to be operated on a mains supply with restricted capacity. Set the EBP value to that of the circuit breaker or fuse to which the amplifier is connected.

Ethernet

Ethernet configurations

IP addressing in the Device can be completely automatic; No setup is required.

When first installing and launching Vu-Net, the computer Firewall may ask to allow Vu-Net to access the network. **NOTE: This must be allowed for both private and public networks.**

DHCP

There are two primary IP address ranges – one used when there is a DHCP server, and another ('Link Local') where there is no DHCP server (so the Device and the Computer will instead use 'Auto IP' to allocate themselves an IP address). Both the device and the computer must be in the same IP address range. In a local network environment such as an office where there is a DHCP server, both the computer and the Device will be in the DHCP IP address range, and so will connect immediately.

AUTO-IP

The device will initially search for a DHCP server when first switched on (during which time its Online Indicator will be flashing). As it can take up to one minute to establish that there is no DHCP server available, this is the time it may take before Auto IP is entered.

Please be aware that it can also take some time from a computer being switched on in an isolated network (without a DHCP server), or unplugged from a network with DHCP to time out of DHCP searching, so it will not connect immediately to amplifiers that are already using Auto IP. The time it takes before it decides to revert to Auto IP depends on the operating system but it can take several minutes to acquire an Auto IP address.

Static-IP

If the device or the computer has a static IP address set, Vu-Net may not be able to 'see' the device if it is in a different IP Address range (i.e. in a different subnet). **Unless there are good reasons it is best to avoid the use of static IP addressing if at all possible unless you have a comprehensive understanding of network systems.**

IP Troubleshooting

If Vu-Net cannot connect to the device:

- A Router acting as a DHCP server is highly recommended as this provides the most trouble-free way of administering IP addresses. Always switch on any DHCP server before connecting either the computer or Amplifier to the network.
- If not using a DHCP server, check that the Current IP address in the device is compatible with the IP address of the computer. Generally, the leftmost two sets of 3 digits should be the same.
- If there is no Router in the system acting as a DHCP server, wait 10 minutes (for the computer to acquire the correct IP address) and try again.
- Check that the Firewall in the computer will allow Vu-Net access to the network **for both private and public networks.**

Snapshots

A Snapshot may be recalled either via the device User Interface, from the Vu-Net application or via the AUX port on the rear of the Device.

The snapshot menu is accessed via the utility pages. Recalling a Snapshot triggers the recalling of a Component to each input and output, and may change other device-wide settings, effectively recalling a processor-wide preset. In addition to being able to recall snapshots from Vu-Net and from the Device's front panel, some of the snapshots are also recallable from the auxiliary port.

See also Aux Port

The parameters inside the Drive Modules are not individually stored in Snapshots. Recalling a Snapshot will merely trigger the recall of the appropriate Input and Output Components, rather than restoring the parameters that were active when the Snapshot was stored. This has the distinct advantage that the library of

OEM presets may be updated without having to be concerned about what parameters might have been saved in users Snapshots. It does however require that any existing edits to the parameters in Drive Modules are stored into Drive Module presets before a Snapshot is stored.

See also Overview of Modules Components and Snapshots

AUX Port

The AUX has two inputs, X & Y. These allow simple contact closure devices (relays or switches) or external logic signals to change the state of the amplifier as described below. Connecting an AUX input to ground (the earth symbol) will trigger it; there is no requirement for an external voltage. However, the ports can also be triggered directly by a logic signal as long as the logic 'low' goes below +0.5V. Do not connect systems if their logic 'high' voltage exceeds +24V.

The AUX port may be configured to work in a number of ways by adjusting the Style parameter in the Aux page of the Utility menu:

- None - No operation
- 2+Mute (Event or State) – Either Snapshot 1 or Snapshot 2 may be recalled by applying a momentary or static connection to an Aux port terminal, or the device may be muted by Grounding both Aux port terminals
- 3 Snaps (Event or State) – Either Snapshot 1 or 2 or 3 may be recalled by applying a momentary or static connection pattern to an Aux port terminals
- 4 Snaps (State) – One of the four Snapshots 1,2,3,4 may be selected by applying a static connection pattern to the Aux port terminals
- 3+Mute (State) - One of the three Snapshots 1,2,3 may be selected by applying a static connection pattern to the Aux port terminals, or the device may be mute by Grounding both Aux port terminals

This table shows the action taken for various Aux connection patterns in the various Aux port modes:

AUX X	AUX Y	2+Mute ACTION (State or Event)	3 Snaps ACTION (State or Event)	4 Snaps ACTION (State)	3+Mute ACTION (State)
Open	Open	No Change	No Change	Recall Snapshot 1	Recall Snapshot 1
Gnd	Open	Recall Snapshot 1	Recall Snapshot 1	Recall Snapshot 2	Recall Snapshot 2
Open	Gnd	Recall Snapshot 2	Recall Snapshot 2	Recall Snapshot 3	Recall Snapshot 3
Gnd	Gnd	Mute	Recall Snapshot 3	Recall Snapshot 4	Mute

Some of the above modes allow the AUX Port to be used either in Event mode (whereby a momentary push-button or momentary relay contact closure on one of the AUX lines will cause a Snapshot to be recalled). Or in State mode (where a rotary switch etc. connected to both of the AUX lines selects which Snapshot to use). Some of the other modes only allow State mode, requiring the connection pattern to persist in order for the Snapshot to be held as the current one.

NOTE: That if the contact closure port is being driven, or if the Aux Style is set to one of the State modes, this will override the snapshot recall setting in the menu (or in Vu-Net). Also under these conditions, the snapshot menu items are not accessible, and the Home screen will show the Snapshot number as a reminder.

See also Snapshots.

Latency delay

All Digital Signal Processing, and conversion between different formats of signal – analogue/digital/network etc., necessarily introduce some delay (latency) to the signal path. Of course, we strive to minimise these latencies. Small as they are, it is sometimes useful to know their precise values. The following describes the principal latencies introduced by various parts of the Device product:

Input / Output Latencies

	Analogue Input	0.385ms
OR	Digital input at 96 KHz sample rate	0.5ms
OR	Digital input at 48 KHz sample rate	0.66ms
	Analogue Output	0.402ms
OR	AES3 Output	0.1ms
OR	Dante Output	0.5ms

Processing Latencies (limited to a minimum of 1.53ms):

	Input HiShelf FIR	0.48ms (0ms if set to 'Off')
	LIR Linear Phase crossover	1.19ms/Fhp(kHz), limited to 30ms maximum **
	VxLim Limiter (VX mode off)	0.12ms/Fhp(kHz), limited to 1.53ms maximum **
OR	VxLim Limiter (VX mode on)	0.358ms/Fsplit(kHz), limited to 1.53ms max ‡‡

** This latency figure is calculated using the crossover High-pass frequency (in kHz)

‡‡ This latency figure is calculated using the Vx Split frequency (in kHz)

Important tip: The processing latency is constant at 1.53ms unless LIR crossover filters or FIR HiShelf EQs are used, so normally you would just need to add the Input and Output delays to this constant value. If LIR or FIR are in use, the Processing latency of a Drive Module may increase beyond this figure. The Drive Module Latency may be viewed on the Latency page of the relevant Input DSP channel. This can be accessed by pressing Input then down until the latency page is reached.

When LIR, is used the Vx Limiter can take the overall latency above the 1.53ms. When high pass frequency is set below 40Hz the filter will automatically revert to Linkwitz riley, this is set so that the latency will not exceed 30ms as stated.

Note that the latency reported on the Latency screen in the utilities menu does not include the Input/Output latencies.

When using input FIR filters, LIR or VX Limiters always check the view latency screen to see the latency attributed to that Drive Module.

Example:

Input/Output	
Analogue Input	0.385ms
Analogue Output	0.402ms
Processing	
Input HiShelf FIR (Off)	0ms
LIR Linear Phase crossover (500Hz)	2.38ms
VxLim Lim (VX mode on, 1KHz Fsplit)	0.358ms
Total	3.525ms

Note that the latencies within a Drive Module are equalised among outputs of that Drive Module. That is, padding delay will be automatically added to some outputs such that the total latency is the same in each output of a Drive Module.

This latency equalisation does not extend outside a Drive Module, so Drive Modules are not guaranteed to have the same latency as one-another.

Secure Mode

When activated, this will disable all the front panel controls so they cannot affect the signal path, making the unit secure against tampering. The only option that is left for user control is snapshot recall. If this is not required then storing the same device state in every snapshot will effectively disable this feature. When in secure mode, the indicators still operate normally. To activate secure mode, press and hold the utility button for 5 seconds. To deactivate, press and hold the utility button for 5 seconds. When in secure mode, this will be shown on the display. Note that the Ethernet communications port is still active in secure mode.

Overlay Flush

If the device has been used in Module Groups, and still has an active Overlay (as indicated by the Overlay indicator), these can be removed by simultaneously pressing and holding for 5 seconds the Utility and Enter buttons. See *Overlays*.

Revert to Factory Settings

If you wish to erase all of your settings in the device and revert everything to factory settings, then simultaneously press and hold for 5 seconds the Up button and the Mute 1 button, then follow the prompts on the display. Only continue by pressing the Enter button if you are sure this is what you want to do. Otherwise, press the Down button to escape. Alternatively, you can access this feature from Vu-Net application using the 'Hamburger' button on the bottom-right of the device control panel, selecting 'revert to factory settings'.

Protection Systems

Comprehensive protection features preserve the longevity of the loudspeaker and amplifier by continuously monitoring several critical parameters, and reducing the gain, or muting the amplifier either temporarily or permanently depending on the nature and seriousness of the fault or misuse. The amplifier will recover and restart if at all possible, but may remain in shut down if a serious fault persists.

Limiters deal with routine over-driving of the amplifier, making sure that the driver(s) are not pushed too hard. The limiter indicators will warn you when the driver is being driven into limit.

Minor faults are dealt with by 'dimming' the amplifier, reducing the level to a sufficient degree and for a sufficient time that the amplifier is able to recover gracefully without any user interaction. When the fault condition has passed, the amplifier will recover automatically.

When the protection systems are reducing the level, this is indicated by illuminating the left-hand Amplifier channel protection indicator. This will also illuminate when the output voltage is 'clipping'. This indicator will remain permanently illuminated if the channel has been muted by the protection systems. The Mute button will also flash. This will usually also be indicated by a warning message on the display. Some types of protection affect all output channels, so you may see the Amplifier indicator illuminated, and the Mute button flash, on every channel.

Summary of Protection Indication

The reasons for the protection indicators illuminating are summarised as follows:

Amplifier Indicator	Driver Indicator	Notes
	Limiter 6dB over	
	Thermal limiting	
	Excursion limiting	
Amplifier clipping		
Amplifier clip limiting		
Amplifier Current limiting		
Amplifier VHF limiting		
PSU Current limiting		Will show on all output channels
PSU Power limiting		Will show on all output channels
Thermal limiting		Will show on all output channels

Incident Reporting

In the Vu-Net application, a coloured indicator appears on a Device Bar in the System View which displays the Incident state of the device. The Incident state may be one of three states:

- Red: Fault (The device is faulty in some way and requires attention)
- Yellow: Check (The device may not be performing to its full and should be checked)
- Green: OK (The device is performing well and requires no attention)

Holding your mouse over the Incident indicator for a few seconds will show the current incident level and name.

If an incident is reported you can disable it, and all less serious incidents, by right clicking the bar in System View and selecting 'Enable/Disable Alarms'. Doing this will show a cross over the Incident indicator and the device will no longer report any Incidents at this level or below.

If any Incidents have previously been disabled they can be enabled by using the right click context menu and selecting 'Enable/Disable Alarms' again.

Any active incident will be shown on the display of the device.

A Fault state will also cause the Fault Relay to open. *See Fault Relay*

Fault Relay

Three connections are available via the Phoenix connector for this relay. The schematic representation printed on the rear panel shows the 'idle' state of the relay (when the amplifier is not switched on). When the amplifier is switched on, the relay will normally energise. When a Fault incident occurs, the relay will be de-energised. This will allow either a Fault Incident or a loss of power to be seen as a 'Fault'.

See also Incident Reporting

Performance Logging

The Vu-Net application allows you to inspect various performance measurements, including various graphs of performance against time, recording events over a period of up to three days. Since the amplifier cannot record any events whilst powered-off, breaks in a log due to power-downs are indicated by a break symbol || in the log.

The events recorded are:

Supply Current - How much current is being supplied to the device via the mains inlet

DC Link Voltage – A voltage which is derived from the mains supply voltage

Thermal Capacity – How much of the available thermal capacity has been used

Driver Current (for each output) – The average current being delivered to the driver

Driver Impedance (for each output) – The average impedance of the driver

Protection Limiting (for each output) - How much the amplifier is 'dimming' itself in order to protect itself from potential damage

The data in the log can be exported by right-clicking on the log to launch a context menu, and selecting "copy log data to clipboard". The data could then be pasted into a spreadsheet for further analysis. Your dealer may ask you to do this if you have experienced a problem. Alternatively, all of the operational and performance data, including the logs may be collected together into a single file by selecting File > Save Device Diagnostics. Your dealer will be able to read and interpret this data.

Vu-Net

iKon amplifiers feature an Ethernet connection to allow them to be networked together for control and monitoring of the system they are driving. This is achieved using a PC on the same Ethernet network running Martin Audio's Vu-Net software. Vu-Net allows comprehensive control of every amplifier function;-



Vu-Net is available as a free download from the Martin Audio website. For full details of Vu-Net operation please also download the Vu-Net User Guide which shows Vu-Net operation for the iKon amplifiers and all Vu-Net enabled Martin Audio products.

TIPI Control

Protocol Overview

Tipi is a simple but powerful ASCII text based protocol for controlling and monitoring IKON Amplifiers from any number of third party control panels or software applications over Ethernet (TCP/IP).

Physical layer

Tipi would typically be transported using an Ethernet Interface (10/100/1G) using the TCP/IP protocol, port 51456.

The user would normally select which 3rd party type to use via the "Third Party Control" parameter on the controlled device, with the selections: "None", "TCP", "Serial".

General frame format

- 8-bit ASCII text strings are used throughout
- The start of a message is delimited by a \$ character
- Fields are separated by one or more space characters (although no space is required after the Start delimiter (\$) or before the End delimiter (<CR>))
- Spaces may *not* be used in name fields. We suggest the use of underscore instead (_).
- Numbers are expressed in decimal units
- The case of alpha letters is not important (although Upper Case Commands (e.g. SET) and CamelCase Method names (e.g. Out1/Gain) will be used in all responses)
- The general format is SD C M VE - where:
 1. S is the Start character = \$
 2. D is the (optional) Device Address (either the DeviceName. This is normally only required when using a multidrop RS485 connection. If the address is implicit (in the case of an IP or RS232 connection for example), then this field may be omitted (so the string then starts with a Command. An absence of this field (i.e. when the frame starts with a Command) indicates 'any' (either the device is implicitly nominated by an IP address, or this is a broadcast). The address must always be preceded with the '#' delimiter. (See Addressing)
 3. C is the Command type (GEt, SEt etc). A minimum of two characters is required; others may be omitted (e.g. SE, ge). The full command is returned by devices in any responses.
 4. M is the Method name (such as Out2/Eq3Freq), describing which parameter is to be acted upon. The MethodName is sometimes made up of concatenated sub-fields separated by a forward slash ("/"). These fields are usually:
 - a. The Path (the input/output name/number) e.g. "Out1". Valid path names are of the form: "In1", "InA", "Out1"
 - b. The Parameter name - e.g. "Eq1Freq". 3.7.4.3. The full MethodName in this example would be "Out1/EqFreq".
 - c. Methods which are not associated with particular input/output channels do not have a Path name or the forward slash(/), so are simply of the form "Snapshot". A typical command string then might be: \$SET Snapshot 8<CR>
 5. V is the value (such as "-3.8dB"). The units of measure are merely for convenience of reading, so may be omitted ("-3.8" in this example).
- E is the end delimiter: Carriage Return (<CR>) (ASCII 13, 0x0D Hex). Note that an LF or NUL character may also be appended in addition to <CR>. 3.8. Any characters outside of a S...E frame are ignored

Addressing

- Since Ethernet and RS232 connections will necessarily be discrete 1:1 connections, it will not usually be necessary to specify addressing in the script. However, a Destination device address may be specified. This might be useful for example in multi-drop RS485 connections.
- A destination address is specified as the DeviceName preceded by #
- If the string after the start character begins with a command (rather than '#'), then the address is considered to be wildcard (broadcast). This only has relevance for multidrop RS485 since RS232 and TCP/IP connections have implicit addressing.
- Example: \$#LobbyAmp SET Out2/Gain 3.5dB<CR>
- Note that spaces in device names are not permitted. Use underscore instead e.g. "Lobby_Amp"



- In an RS485 network, the user will need to ensure that there are no duplicate DeviceNames on the network.

Commands

- A command tells the connected device what general action is to be performed
- Defined commands are:
 1. **SET** This tells a receiving device that it should set the value of the specified parameter to a particular value.
Example: \$SET Out2/Gain 3.5dB<CR> 5.2.2.
 2. **GET** This requests the value of the specified parameter. The receiving device will return a "NOTIFY" command, appended with the value of that parameter.
Example: \$GET Out8/Eq2Freq<CR>.
Response: \$NOTIFY Out8Eq2Freq 330Hz<CR>
Note that since parameter values are quantised in the device, the value returned in any subsequent GET response may not be exactly the same as the value in a SET command. For example, \$SET Out1/Gain -22.415dB<CR> might set the parameter value to -22.42dB. Similarly, if a SET or CHANGE command attempts to set a parameter to a value outside of its permitted range, a subsequent GET command will return the permitted value.
 3. **NOTIFY** Used to respond to a GET
 4. **VERSION** This requests the version of the scripting protocol, which may be enhanced from time to time. There are no further parameters for this command.
Example: \$VERSION<CR>
The response is similar to a GET; i.e. \$NOTIFY VERSION 1.28<CR>
 5. **ERROR**. This is returned when the message was erroneous. Error responses will return the original message, prepended with ERROR and appended with a brief error description and an error number. Examples of error responses are:
A message is badly formed: \$ERROR <original message> BadCommand 06<CR>
The Method was not supported in the device: \$ERROR <original message> UnsupportedMethod 09<CR>

Responses

There are several types of response:

1. **ERROR** (when the message is erroneous)
2. **NOTIFY** (when a device sends back a parameter value in response to a Get: \$NOTIFY Out2/Eq3Gain 2.6dB<CR>)

MethodNames

For each type of device, a list of compatible MethodNames is published. Please refer to the documentation for the specific device.

Security

Not all the published MethodNames will be accessible; some of these might have been 'locked' by the vendor.

Parameter Values

Parameter Values are stated in 'natural' units of measure (e.g. Hz, dB etc) in decimal format with any desired precision (although this will be truncated to the precision the device is capable of interpreting).

Although not necessary, for convenience, a suffix may be added after the value to indicate units of measure (without a space). Examples are:

- **Hz** //Freq type (e.g. 650.3Hz)
- **Oct** //Bandwidth type (e.g. 0.32Oct)
- **dB** //dB type (e.g. -3.4dB)
- **ms** //Time type (e.g. 120.3ms)
- **X** //multiplier type (e.g. 3.2X)
- **:1** //Ratio type (e.g. 4:1)
- **W** //Power type (e.g. 452.3W)
- **R** //resistance type (Ohms) (e.g. 4.2R)
- **Min** //minutes type (e.g. 122.5Min)
- **C** //temperature type (e.g. 34.5C)
- **V** //voltage type (e.g. 233.6V)



- A //current type (e.g. 72.3A)
- % //percent type (e.g. 52.5%)
- Blob //Binary Large Object (blob) type

We suggest no suffix for Integer, Select or Boolean values.

Boolean values are represented using one of the two values: Yes or No (e.g. Out1/Mute Yes)

The values of select types (such as “24dB Bessel”) are conveyed using index numbers which we publish.

Multipliers etc (such as k for 1000) are *NOT* supported. 15kHz must be scripted as 15000Hz.

Script Examples

1. \$SET Snapshot 5<CR> – Recall Snapshot 5
2. \$SET Out1/Mute yes<CR> – Mute channel 1
3. \$SET InA/Gain -3.2dB<CR> – Set the gain of input A to -3.2dB

Tipi Methods for IKON Amplifiers

Parameter	MethodName	Channels	Minimum Value	Maximum Value	Actions	Example
Input Gain	InA/Gain	InA..InD	-40dB	20dB	Get, Set	SET InB/Gain -3.2dB
Input Mute	InA/Mute	InA..InD	false	true	Get, Set	SET InD/Mute yes
Output Gain	Out1/Gain	InA..InD	-40dB	20dB	Get, Set	SET InB/Gain -3.2dB
Output Mute	Out4/Mute	InA..InD	false	true	Get, Set	SET InD/Mute yes
Snapshot	Snapshot	-	1	10	Set	SET Snapshot 5

Power Draw & Thermal Dissipation

iK42

Sleep mode (slow wake up)					
AC Mains Power Draw (Watts)	Current Draw (Amps)		Thermal Dissipation		
	120Vac	230Vac	Watts	kcal/hr	btu/hr
4.5	0.4	0.2	4.5	4	15

Standby mode (fast wake up)					
AC Mains Power Draw (Watts)	Current Draw (Amps)		Thermal Dissipation		
	120Vac	230Vac	Watts	kcal/hr	btu/hr
60	1.0	0.5	60	52	205

Running with no audio signal					
AC Mains Power Draw (Watts)	Current Draw (Amps)		Thermal Dissipation		
	120Vac	230Vac	Watts	kcal/hr	btu/hr
195	2.9	1.5	195	168	665

Running in 2 Ohm mode* (all channels driven)							
Load (ohms)	Signal duty & Crest Factor	Input power (Watts)	Current Draw (amps)		Thermal Dissipation		
			120Vac	230Vac	Watts	Kcal/hr	Btu/hr
2	1/8, cf = 4.0 (12dB)	3000	33.5**	17.5	500	430	1706
4	1/4, cf = 2.8 (9dB)	3475	28.8**	20.3	475	408	1621
4	1/8, cf = 4.0 (12dB)	1780	19.7	10.3	280	241	955
8	1/4, cf = 2.8 (9dB)	1750	19.2	10.0	250	215	853
8	1/8, cf = 4.0 (12dB)	975	11.0	5.8	225	193	767

Notes

- The amplifier was configured to have no audio processing
- Measurements were performed with a Hameg HM8115-2 power analyser
- All measurements were done at 230Vac, 50Hz.
- The Current Draw figures for 120Vac are calculated
- *The M20 does not have 4 & 8 Ohm Low Z modes
- **The EBP limiter should be set to 32A, but will not activate on any sensible program material

iK81

Sleep mode (slow wake up)					
AC Mains Power Draw (Watts)	Current Draw (Amps)		Thermal Dissipation		
	120Vac	230Vac	Watts	kcal/hr	btu/hr
4.5	0.4	0.2	4.5	4	15

Standby mode (fast wake up)					
AC Mains Power Draw (Watts)	Current Draw (Amps)		Thermal Dissipation		
	120Vac	230Vac	Watts	kcal/hr	btu/hr
60	1.0	0.5	60	52	205

Running with no audio signal					
AC Mains Power Draw (Watts)	Current Draw (Amps)		Thermal Dissipation		
	120Vac	230Vac	Watts	kcal/hr	btu/hr
204	3	1.55	204	175	696

Running (all channels driven)								
Load Mode	Load (ohms)	Signal duty & Crest Factor	Input power (Watts)	Current Draw (amps)		Thermal Dissipation		
				120Vac	230Vac	Watts	Kcal/hr	Btu/hr
2 Ohm	2	1/8, cf = 4.0 (12dB)	1703	20.4	10.6	453	390	1547
2 Ohm	4	1/4, cf = 2.8 (9dB)	1652	19.8	10.3	402	345	1371
2 Ohm	4	1/8, cf = 4.0 (12dB)	938	11.9	6.2	313	269	1069
4 Ohm	4	1/4, cf = 2.8 (9dB)	2967	31.6	16.5	467	401	1592
4 Ohm	4	1/8, cf = 4.0 (12dB)	1617	20	10.4	367	315	1251
4 Ohm	8	1/4, cf = 2.8 (9dB)	1605	19.2	10.0	355	305	1211
4 Ohm	8	1/8, cf = 4.0 (12dB)	920	16.6	6.1	295	254	1007
8 Ohm	8	1/4, cf = 2.8 (9dB)	2825	33.1	17.3	325	279	1109
8 Ohm	8	1/8, cf = 4.0 (12dB)	1567	18.48	9.6	317	272	1081

Notes

- The amplifier was configured to have no audio processing
- Measurements were performed with a Hameg HM8115-2 power analyser
- All measurements were done at 230Vac, 50Hz.
- The Current Draw figures for 120Vac are calculated

Processing Block Diagram

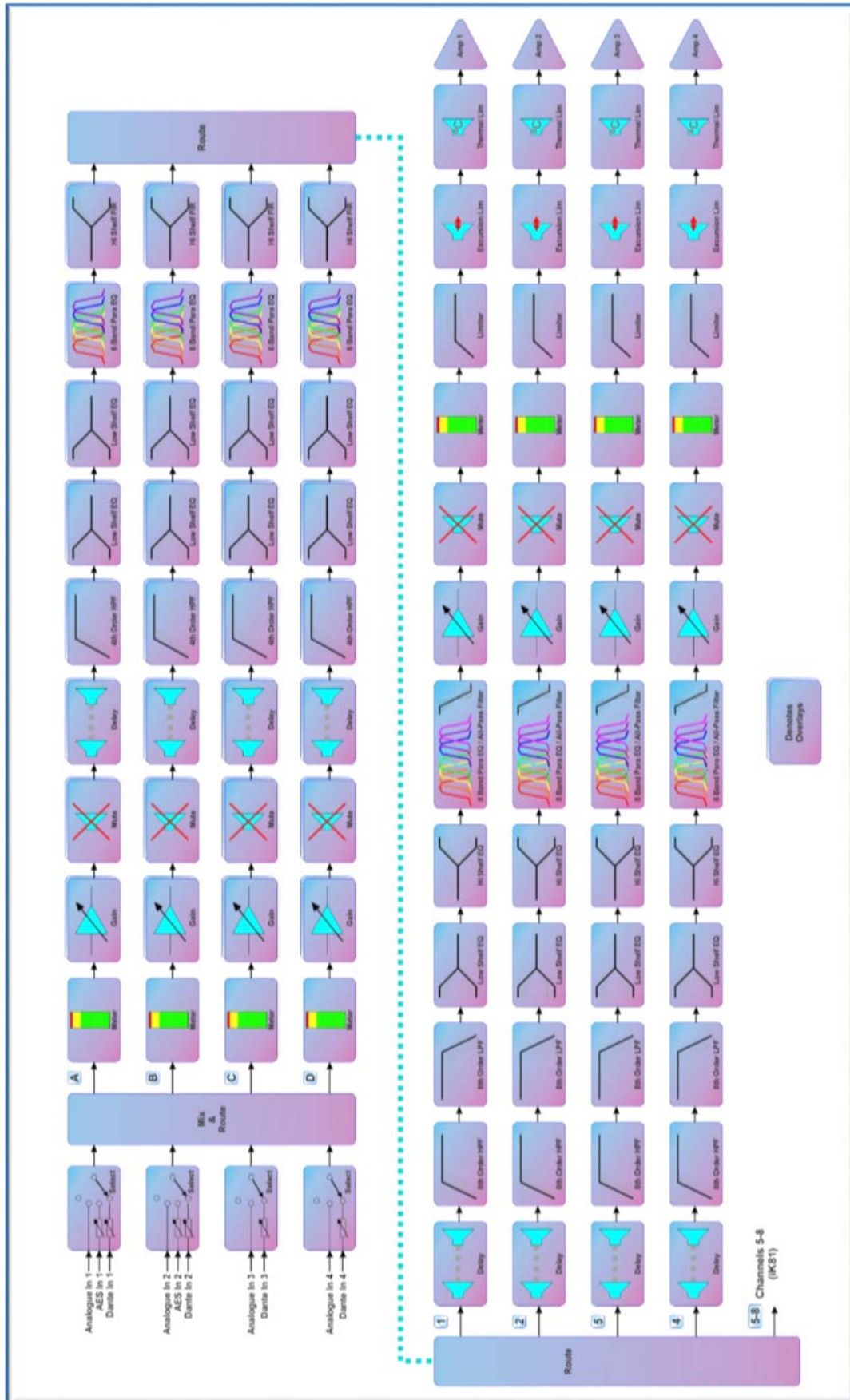

Input Menu Map

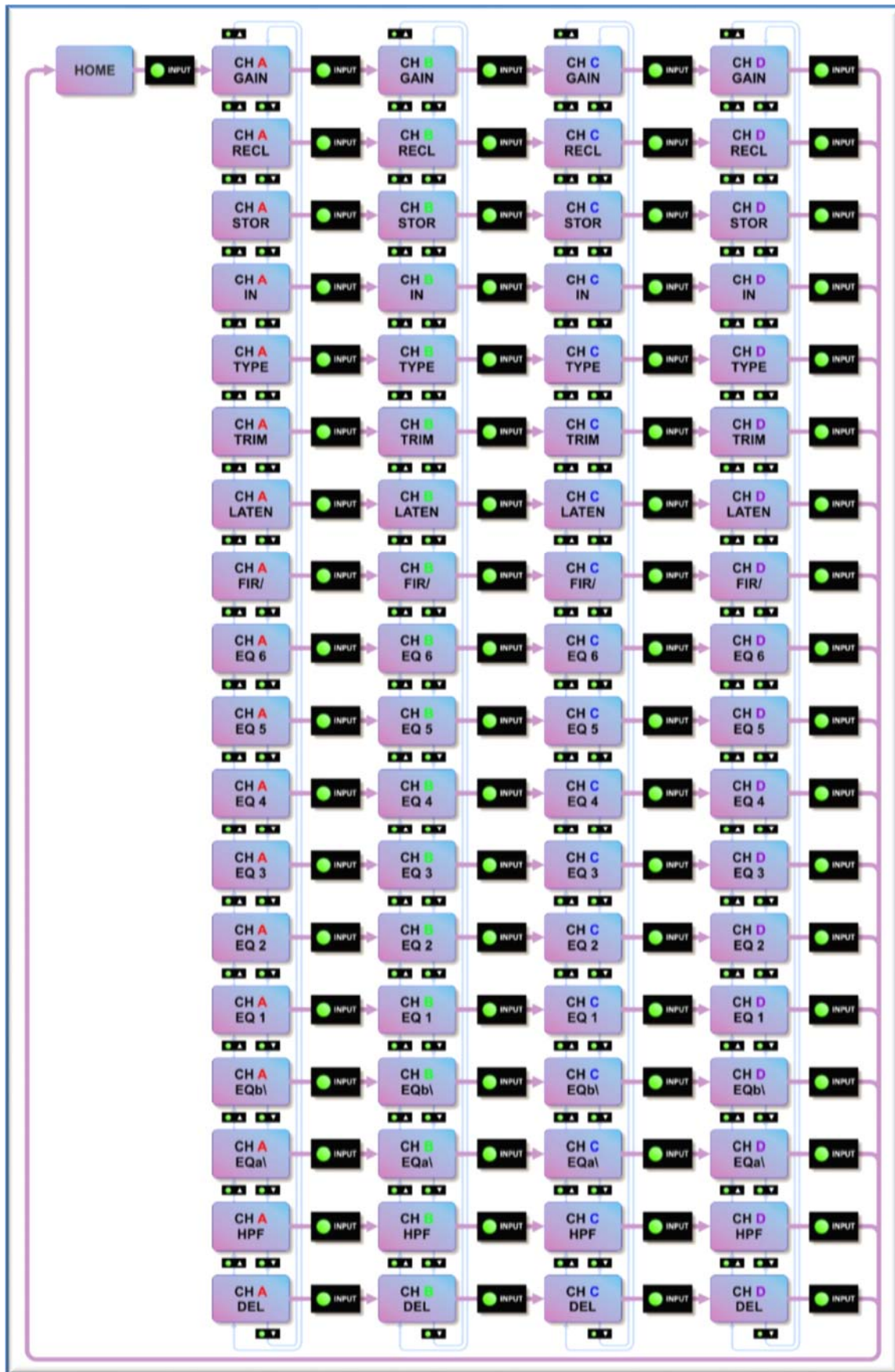

Output Menu Map

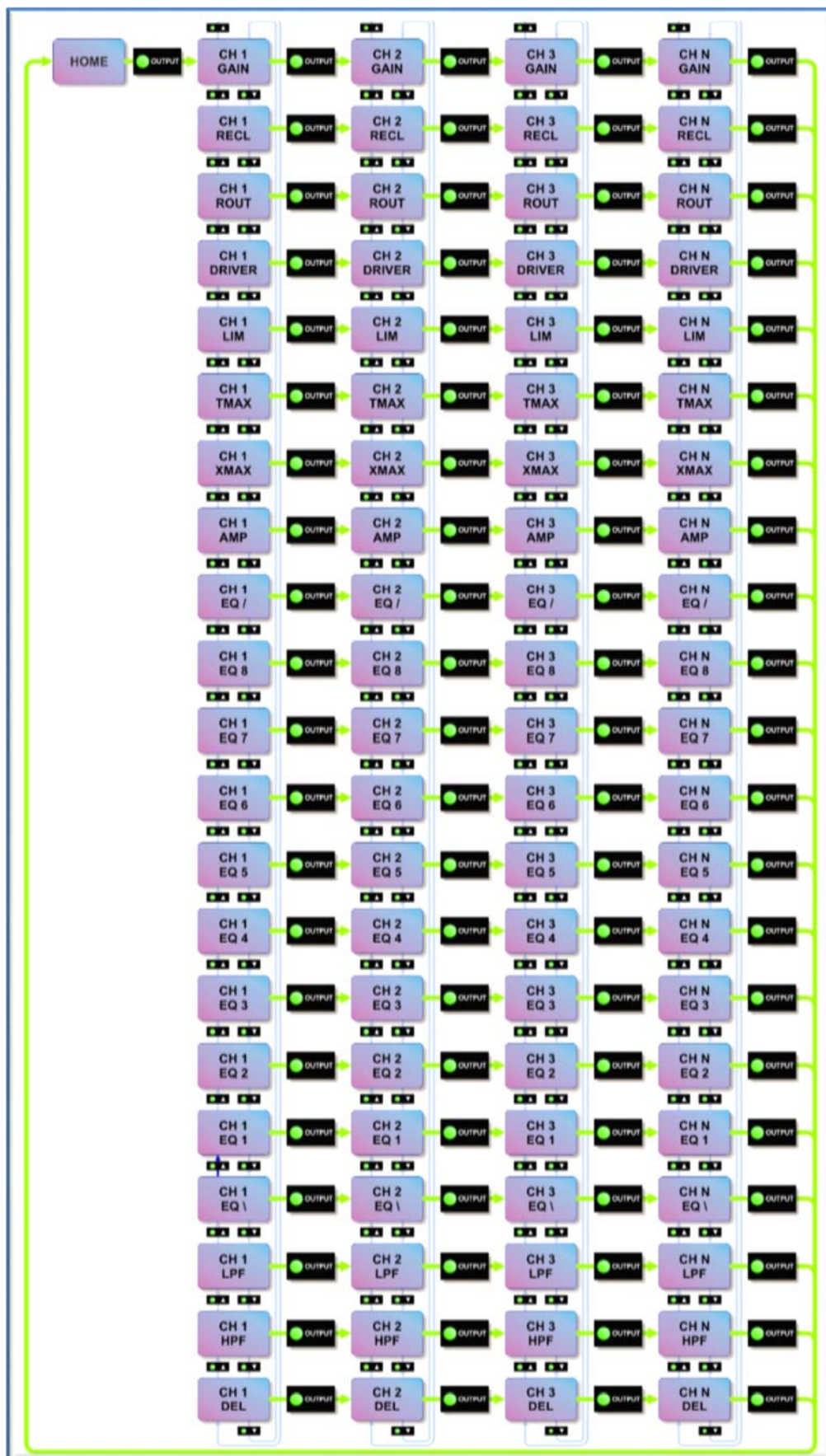

Utility Menu Map

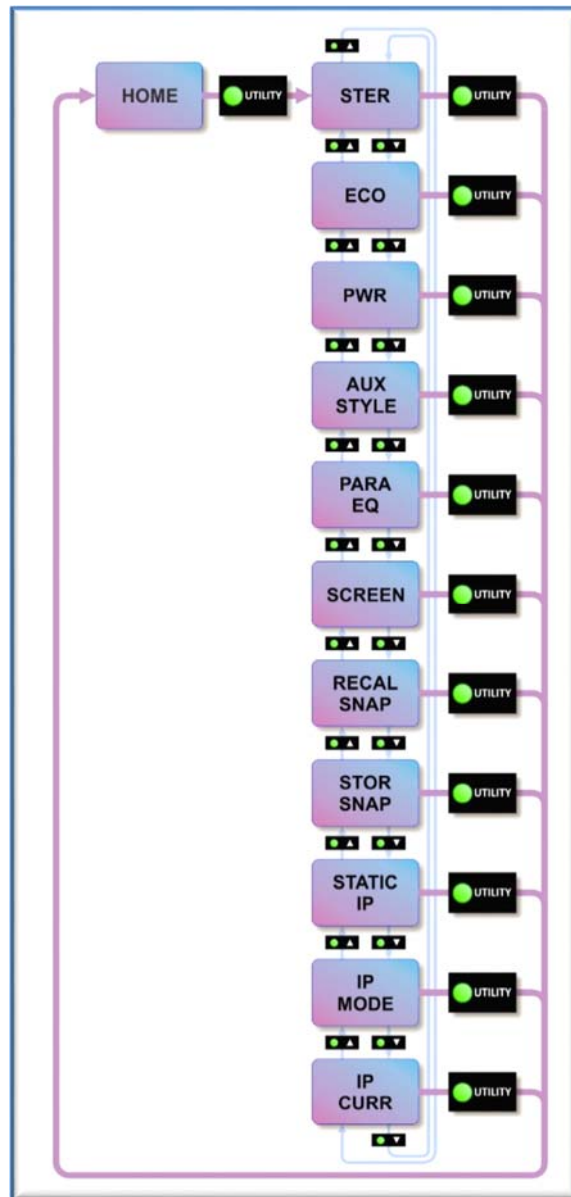

EQ and Filter Response Graphs

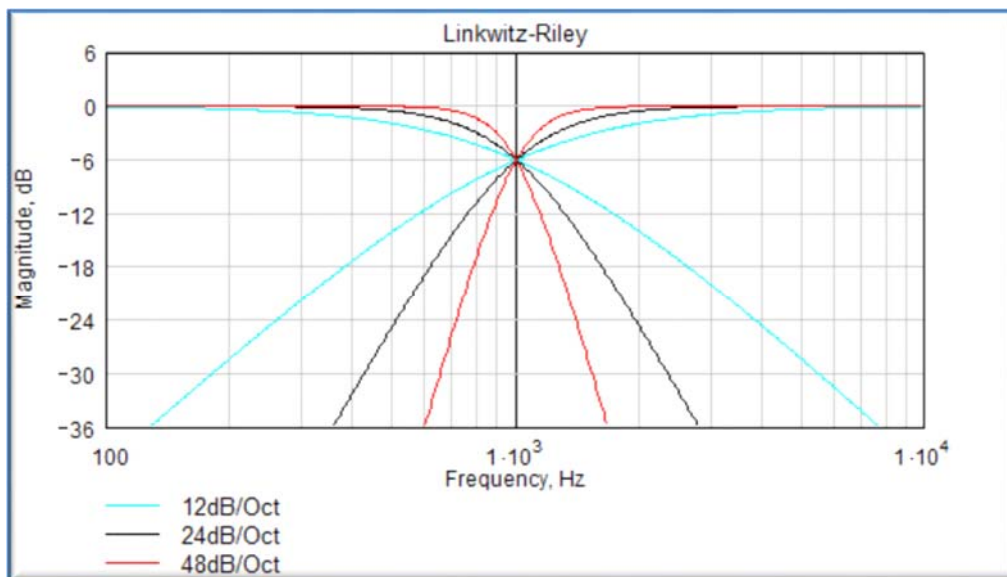
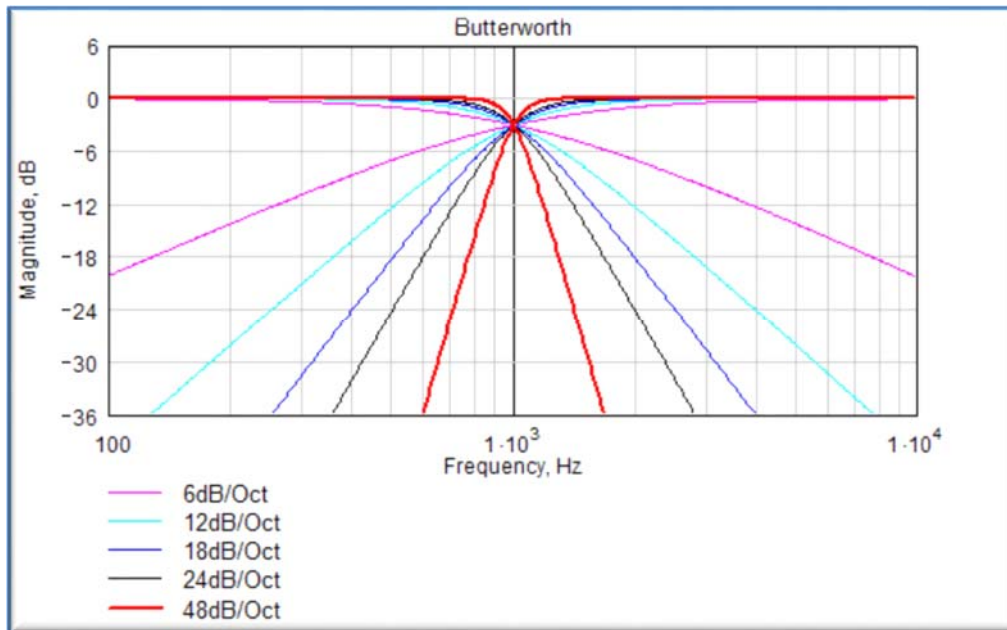

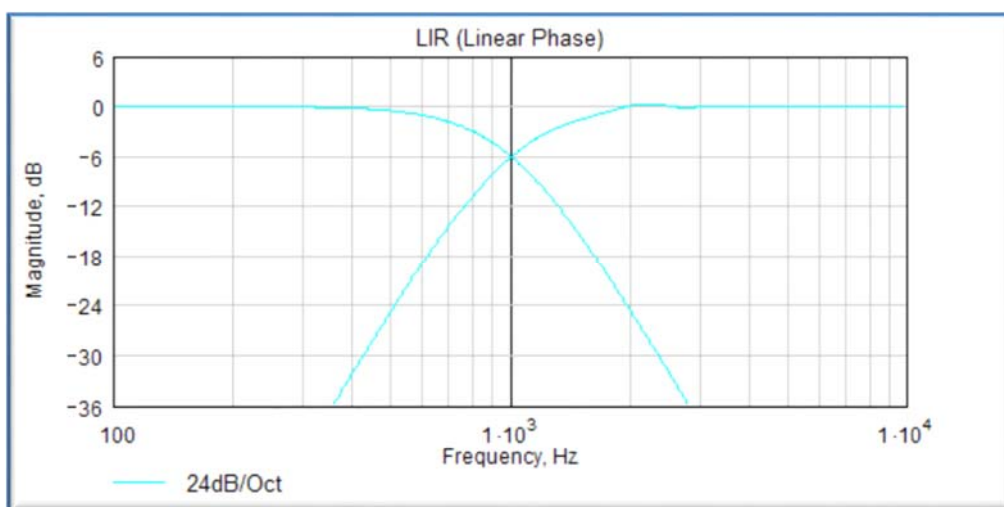
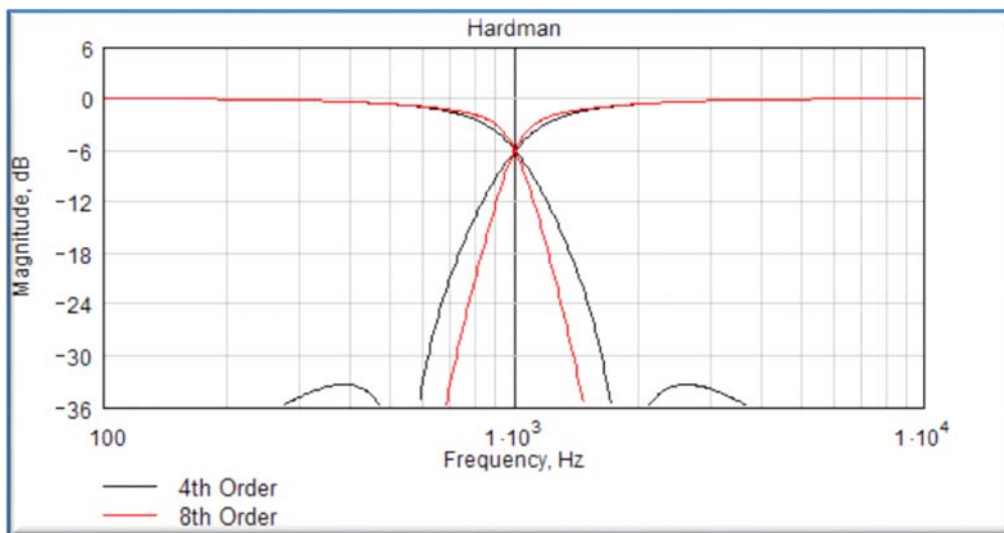
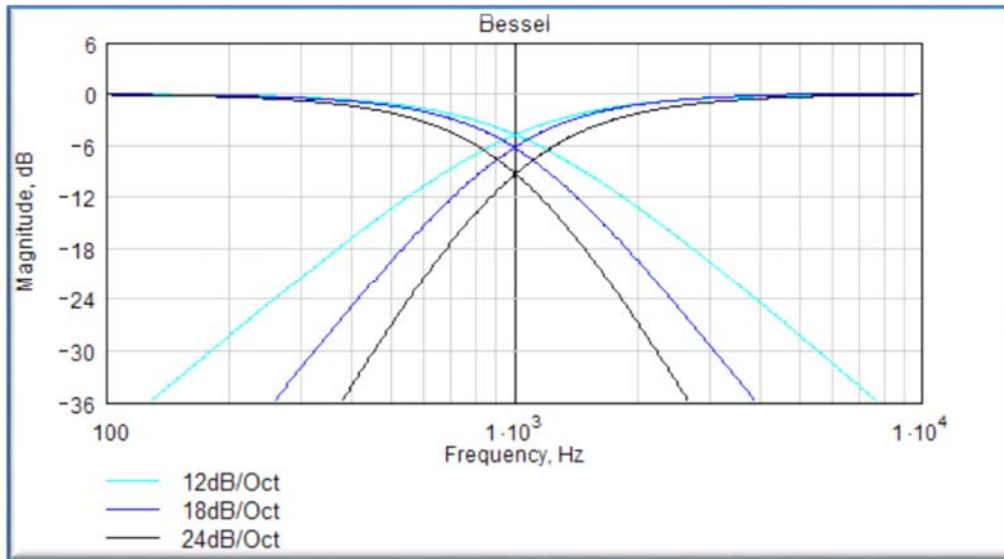

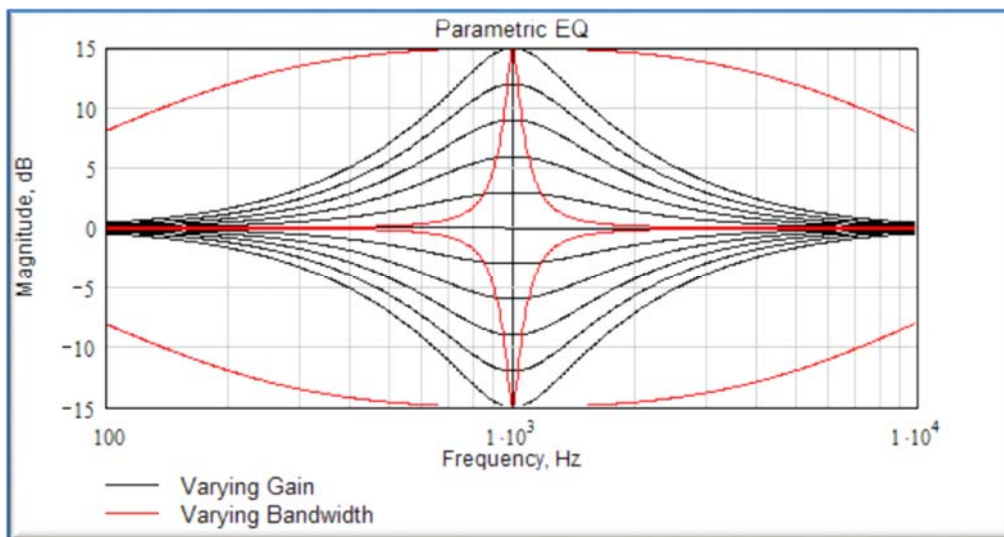
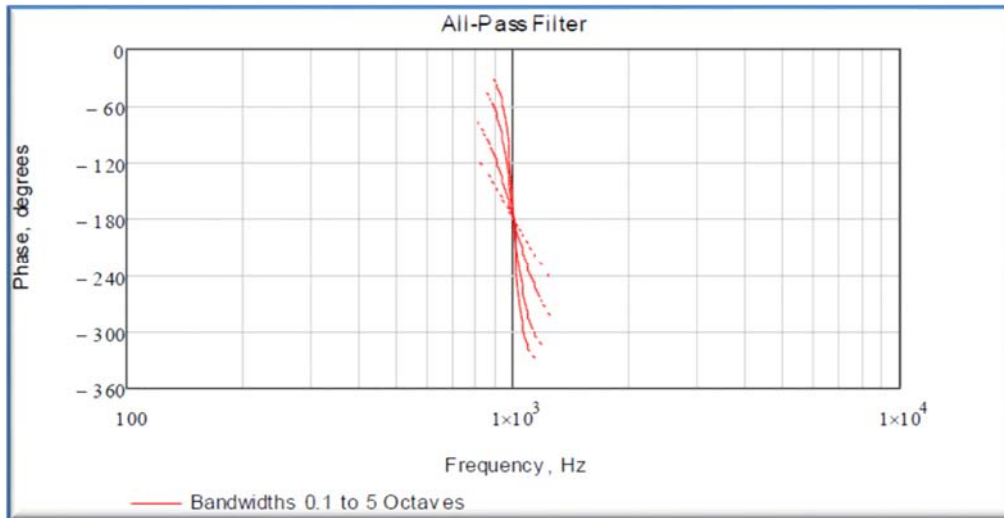

Technical Specifications

General

Number of Output channels	Four (iK42) or Eight (iK81)
Total power output (iK42)	20,000/10,000/6,000 Watts RMS (iK4220, iK4210, iK4206)
Total power output (iK81)	10,000/6,000/3,000 Watts RMS (iK8110, iK8106, iK8103)
Input types	Analogue, AES3, Dante
Control, monitoring & alarm	Ethernet, configurable function Volt-free relay and contact closure port
Energy saving modes	Standby and deep sleep, both with auto-sleep timers
System sleep and wakeup	Front panel switch, network command, contact closure and audio detection
Max ambient temperature (full power, no limiting)	40degC (105degF)

Audio

Amplifier topology	Proprietary 5th generation Martin Audio Class D
Amplifier modulation scheme	Low feedback, multiple loop, with feedforward error correction
Dynamic range (analogue input to speaker output)	>113dBA typ.
Dynamic range (AES3 or Dante input to output)	>114dBA typ.
Frequency response	<7Hz to >30kHz, 4 Ohms, -2.5dB.
Total harmonic distortion, THD	<0.05% typ, 1kHz, AES17, 4 Ohms.
Inter-channel crosstalk (worst combination of channels)	Better than -85dBr at 1kHz. Better than -75dBr at 10kHz.
Slew Rate	>60V per microsecond typical
Damping factor (Ref 8 Ohms)	>800 at amplifier output
Maximum analogue input level	+20dBu.
Analogue input sensitivity range for full output	0dBu to +20dBu, continuously adjustable.
Analogue input	20k Ohm, electronically balanced.
Analogue link	Directly connected to the analogue input.
Analogue ground scheme	AES48 standard compliant.
AES3 input	Transformer isolated with active cable equalisation for extended range
AES3 link	Active signal regeneration with automatic direct bypass to the AES3 input if the unit is unpowered.
AES3 supported sampling rates	24kHz to 192kHz (auto locking).

Digital processing

Resolution	40 bit, using proprietary LMD (Linea-Micro-Detail) algorithms
Sample rate	96kHz throughout
Special functionality:	Class leading limiter suite (See the 'speaker protection systems' section)
	Hardman crossover filters (Better out of band rejection than Linkwitz-Riley)
	LIR crossover filters (Linear Phase without the compromises of FIR filters)
	FIR Shelving EQ filters (For linear phase filtering).
	Overlays (Twelve additional independent overlays of EQ, Delay and Gain)

Power Output iK42

Power specification	RMS output power per channel, all channels driven with continuous program material and a nominal ambient temperature of 40degC / 105degF
Crest Factor of 4 (12dB), 2-Ohm nominal load	5,000W
Crest Factor of 2.8 (9dB), 4-Ohm nominal load	3,000W
Crest Factor of 2 (6dB), 8-Ohm nominal load	1,500W
Bridged, per channel pair, 4 Ohm load	10,000W
25V line (CV) operation, Crest Factor 4 (12dB)	1250W
70V line (CV) operation, Crest Factor 4 (12dB)	3500W
100V line (CV) operation, Crest Factor 4 (12dB)	5,000W

Power Output iK81

Power specification	RMS output power per channel, all channels driven with continuous program material and a nominal ambient temperature of 40degC / 105degF
Crest Factor of 4 (12dB), 2-Ohm nominal load	1,250W
Crest Factor of 2.8 (9dB), 4-Ohm nominal load	1,250W
Crest Factor of 2 (6dB), 8-Ohm nominal load	1,250W
Bridged, per channel pair, 4 Ohm load	2,500W
25V line (CV) operation, Crest Factor 4 (12dB)	625W
70V line (CV) operation, Crest Factor 4 (12dB)	1,250W
100V line (CV) operation, Crest Factor 4 (12dB)	1,250W

Power supply

Topology (main power supply)	3rd generation Series Resonant.
Topology (auxiliary and standby supplies)	Low quiescent Eco-Flyback.
Internally stored energy	>600 Joules.
Mains input voltage range (automatically configured)	85V to 240V.
Mains input frequency range	47Hz to 63Hz.
Mains inrush current (max for <10ms)	6A at 115V, 12A at 230V.

Protection systems

Note : Under all circumstances the control and protection systems will endeavour to deliver the maximum power possible for a given set of conditions, applying limiters only in extreme circumstances. Muting will only occur when a dangerous situation is detected, normal operation automatically resuming when the condition clears.

System protection	Speaker protection
Excessive output current	Audio soft-clip limiter
Excessive power supply current	VxLim, Multiband peak limiter
Excessive amplifier section temperature	VxMax, Multiband overshoot limiter
Excessive power supply section temperature	Vx-Xmax, Driver excursion limiter
Excessive DSP section temperature	Vx-Tmax, Driver thermal limiter (long term power limiter)
Mains voltage out of range	DC offset protection
Fan speeds out of range	Excessive HF energy (VHF) limiter
Internal power rails out of range	

Power distribution protection systems

Mains inrush current limiting (soft start and anti-surge).
Mains average current limiting (mains breaker / fuse trip protection).
Randomised initialisation when powered up to reduce the peak power demand in large systems.

Monitoring and logging

Supply current logged vs time	Number of power cycles counted
Supply voltage logged vs time	Number of mains brownout events counted
Thermal Capacity logged vs time	Fan speeds continuously monitored
Each driver current logged vs time	Fan under-speed events counted
Each driver impedance logged vs time	Various protection mute events counted
Protection limiting for each output logged vs time	Driver Impedance continuously monitored

An inbuilt alarm and notification system can be configured to indicate problems to remote devices either via the network or the Volt-free changeover relay contacts accessibly on the rear panel.



Physical

Cooling	Variable speed fans.
Airflow	Front to back.
Air filtration	Washable media, changeable without the use of tools.
Analogue IN and LINK connectors	Genuine Neutrik™ XLR.
AES3 IN and LINK connectors	Genuine Neutrik™ XLR.
Audio output connector	Genuine Neutrik™ Speakon.
Mains input connector	Genuine Neutrik™ 32A PowerCon.
Dante Primary and Secondary	Shielded RJ45.
Relay output & contact closure inputs	Phoenix pluggable terminal block.
Front panel display	Graphical, backlit, high contrast, daylight visible.
Front panel encoders	Two, indented, velocity sensitive.
Front panel push buttons	Large, tactile, illuminated.
LED indicators	Bright, easily differentiated
Enclosure	Standard 19" 2U (88mm) with handles and optional rear support system
Depth (behind rack ears)	357mm (14").
Net Weight	12.5kg (27.5 pounds).

Options

Options	Part Number
Rear rack support kit	