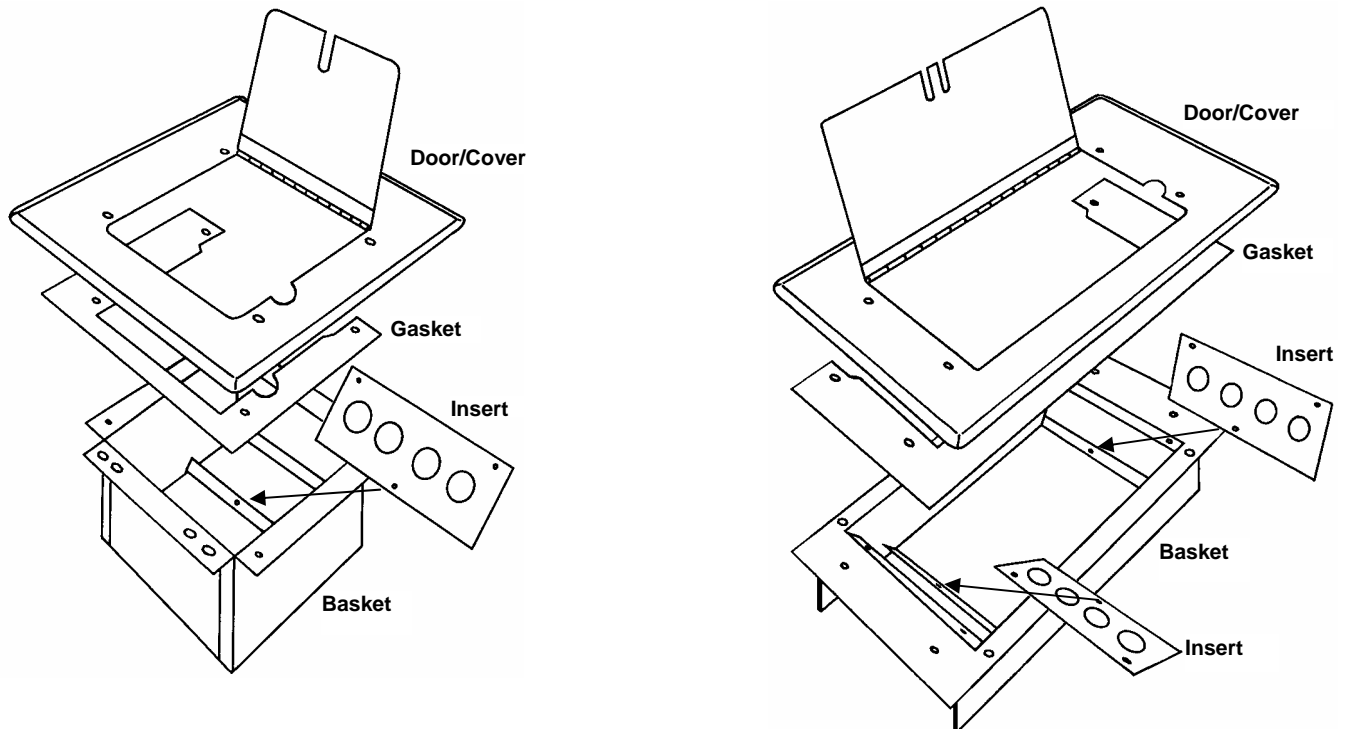

**RE: FMCA 1000/2000 series Installation Instructions****Important Note:**

Mystery Electronics backboxes are UL listed and conform to all applicable N.E.M.A. Standards. While locally available boxes may seem acceptable as substitutes, there are differences in certain critical dimensions. For a fast and easy installation and to avoid costly onsite rework, the user is strongly cautioned to use only Mystery Electronics backboxes. They are proven to be the lowest cost alternative.

**General:**

These instructions are provided to assist in the installation of all FMCA1000 and FMCA2000 series units, and are precise for most routine applications. Further technical support or application-specific instructions are available from our Technical Support Department. The FMCA series includes a variety of Insert Panel types to accommodate most applications with little or no modification. The purpose of this variety is to reduce installation labor and preparation work as much as possible. Laser cut custom inserts are also available or use the cost saving MultiPunch feature to attain custom results as detailed below.

Careful consideration and pre-planning should be given to both the immediate and long-term conditions of the proposed installation. FMCA units are typically located where they might be walked on, rolled over, and generally abused. Every effort should be made to keep the FMCA units out of the path of heavy traffic.

The Mystery Electronics FMCA satin black series 1000 or FMCA satin black series 2000 are not recommended for unprotected outdoor or indoor wet, damp or severe weather locations. The FMCA1100 and FMCA2100 series with solid brass Door/Covers, along with our All Weather Enclosures (AW series) are recommended for outdoor applications.

**Backbox:**

The backbox is an optional item and not furnished with the FMCA kit. Consult TechNote TN12 for backbox installation details. A backbox is required for all conduit system installations. The backbox is optional when a conduit system is not installed but is recommended to maintain secure integrity and ease of the installation. For applications where moderate to heavy traffic or movement of equipment or materials (pianos, scenery, props, "road cases", etc.) is expected, a backbox is strongly recommended.

Run all wiring lines into the backbox before proceeding to mount the Basket. Connector Insert Panel openings in the Basket of all models are large enough to allow most connectors to be mounted on the panel, have connections wired and still be fed thru the Basket. This allows off-site prefabrication. It also effectively prevents inadvertently "getting ahead of oneself".

#### **Basket installation with backbox:**

For backbox applications, align the countersunk holes in the flange of the Basket with the corresponding holes in the top flange of the backbox and install the 1/4" flat phillips head self-tapping screws. The self-tapping screws furnished with the FMCA are designed to thread these holes readily. Make major adjustments for variations in site conditions (i.e. backbox depth below floor, carpet thickness, hardwood floors routed to flush mount the Door/Cover, etc.) by raising or lowering the 1/4" Basket mounting screws. Further adjustment may be required before attaching the Door/Cover to the Basket. **CAUTION:** *The self-tapping screws furnished with the FMCA hardware kit may not provide secure mounting of the FMCA if a backbox other than the appropriate Mystery Electronics backbox is used.*

#### **Basket installation without backbox:**

Use the Basket as a template and cut the opening 1/8" larger than bottom of the FMCA Basket. Substrate failure can occur in particleboard, plywood and even hardwood floors due to the location of the Basket mounting holes at the edge of the cut opening. To prevent this, solid wood blocking strips (1x2 is adequate) must be fastened beneath each side of the cut opening below each Basket mounting flange (two sides only). The wood backing strips should be cut 2" longer than the Basket flange. Place each strip thru the cut opening and pull it up against the underside of the floor. Center the strip along the edge of the opening and fasten it in place with long wood screws from above. TwinFast type screws, having aggressive threads, work very well here. This provides a ledger / backing strip for the Basket to be fastened to. Mount the Basket with four (4) wood screws (not furnished) thru the floor decking and into the backing strip. This effectively clamps the floor between the FMCA Basket flange(s) and the backing strip. Install wiring as required and route wiring lines thru the insert panel opening(s) of the Basket.

#### **Door/Cover:**

Place open side of U-shaped Gasket under the hinge side of the Door/Cover, lining up notch on gasket with finger notch on Door/Cover. Secure the Door/Cover to the Basket with four (4) flathead socket screws, passing thru holes in Gasket. All FMCA units mount to the respective backbox similar to the way a duplex power receptacle mounts in a single gang box. **When properly installed, the Door/Cover should compress the Gasket and "seat" directly onto the Basket without any gap between the Door/Cover and the Basket or the Door/Cover and the floor.** For carpet installations, further minor adjustment should be made by raising or lowering the Basket until Door/Cover "seats" properly as per above. The integral carpet trim flange should pull down into carpet snugly without causing any visible deflection of the Door/Cover. If the Door/Cover exhibits any deflection, raise the Basket until deflection no longer occurs with no gap showing and the edge of the integral Door/Cover carpet trim ring is pulled sufficiently far enough into the carpet so that the FMCA does not move when walked on. Patience in performing this step ensures that the installation will be able to withstand heavy traffic. Only with certain extremely thick carpet and pad combinations will cutting the pad or shaving the carpet be required.

On hard floor surfaces, the integral trim ring edge must be firmly in contact with the hard floor surface. The floor can be routed so that the Door/Cover provides an absolutely flush installation if this is desired.

#### **Connector Insert Panel:**

Install the required number of connectors. Unused spaces may be filled with our HFP series Hole Filler Plugs. This allows future addition of connectors in these spaces while giving a professional, finished look to the installation. We recommend that the connectors be mounted to the Insert Panel with 1/8" stainless steel blind rivets ("Pop Rivet" brand or similar). Experience has shown that aluminum blind rivets often become loose after a short time, causing connectors to wiggle when microphone cables are inserted or removed.

Terminate all connections and secure the Insert Panel(s) to the Basket with three (3) 8/32 button head Insert Panel mounting screws.

---

#### **MultiPunch Feature:**

The MultiPunch feature lends itself to accommodating unusual configurations of connectors. The Type 9 Insert Panel has four of these positions. The MultiPunch position is laid out to accept 1/4" audio, 'F' type video, phono jack, BNC, etc. and similar connectors with little or no modification. By punching out the center hole to the required diameter, it will accept either Switchcraft female D\*F or male D\*M connectors with the connector mounting holes already punched. The center hole is the same size as a "Greenlee" or similar radio chassis punch drive screw to make such modification easier. Some deformation may occur when punching out the center hole of a MultiPunch position close to the edge of the Insert Panel to accommodate a D\*F connector. To minimize this deformation use a sharp punch with the points of the punch oriented to align with an imaginary line from 1/8" below the upper left most D\*F mounting hole to 1/8" above the lower right mounting hole. This moves the last part of the cutting edge of the punch (the last area to contact the metal before the punched out metal separates) away from the narrow edge of the Insert Panel. Any remaining deformation will be covered when the connector is installed.

