



Installation and Assembly Manual:

Vector Pro II™

Models: PJF2-UNV, PJF2-UNV-S



This product is intended for use with UL Listed products and must be installed by a qualified professional installer.

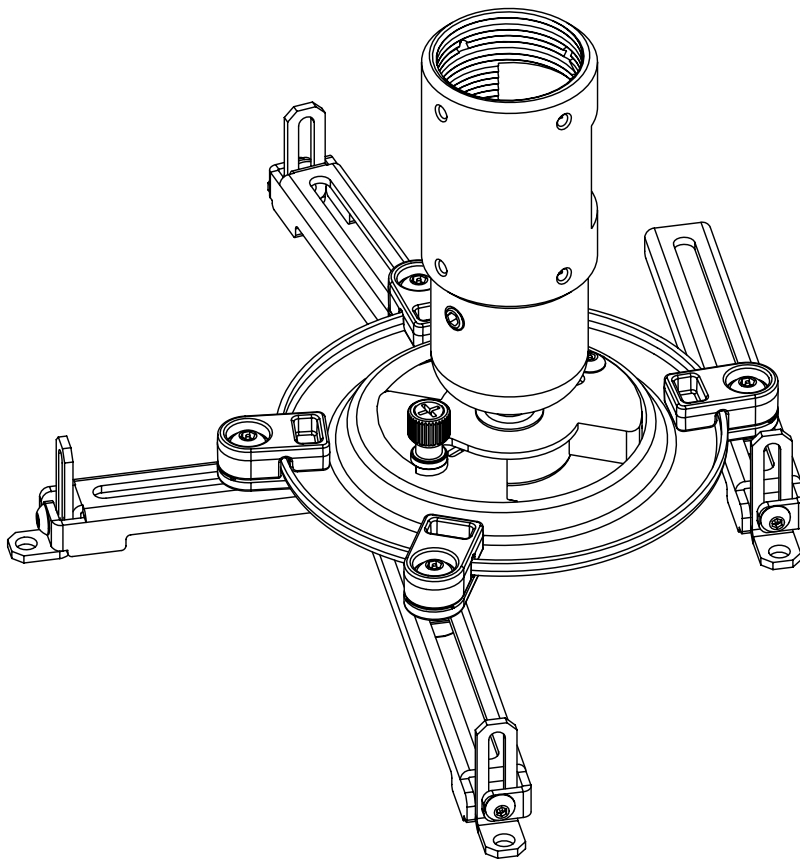

ENG Compatible model/series*	AEC*, EXT*, ADD*, ACC500*, CMJ400*, DCT100, DCS200, CMJ500R1.
------------------------------	--

Maximum UL Load Capacity: 50 lb (27 kg)

Note: Read entire instruction sheet before you start installation and assembly.

WARNING

- Do not begin to install your Peerless product until you have read and understood the instructions and warnings contained in this Installation Sheet. If you have any questions regarding any of the instructions or warnings, call Peerless customer care at 1-800-865-2112.
- This product should only be installed by someone of good mechanical aptitude, has experience with basic building construction, and fully understands these instructions.
- Make sure that the supporting surface will safely support the combined load of the equipment and all attached hardware and components.
- Never exceed the Maximum UL Load Capacity.
- Always use an assistant or mechanical lifting equipment to safely lift and position equipment.
- Tighten screws firmly, but do not overtighten. Overtightening can damage the items, greatly reducing their holding power. See suggested torque values where applicable within these instructions.

CAUTION

- It is the responsibility of the installer to ensure that the projector is properly ventilated. Feet of channels are used to raise the mount off the projector surface.

Tools Needed for Assembly

- stud finder ("edge to edge" stud finder is recommended)
- phillips screwdriver
- drill
- 1/4" masonry bit for concrete surface
- 5/32" bit for wood studs
- level
- 3/8" (10 mm) socket wrench

Table of Contents

Parts List.....	3
Installation to Wood Joist or Wood Beam Ceilings.....	4
Installation to Concrete Ceilings.....	5
Flush Mount Application	6
Installation to Extension Columns	7
Attaching Adapter Plate to Projector.....	8
Attaching Adapter Plate to Projector Mount, Projector Alignment	9

Before you start check the parts list to insure all of the parts shown are included.

Parts List			PJF2-UNV	PJF2-UNV-S
Description	Qty	Part #	Part #	Part #
A ball and socket mount	1	055-0011	055-0016	
B adapter plate	1	055-1867	055-4867	
C ceiling plate	1	580-1042	580-4042	
D extension column connector	1	580-1025	580-4025	
E M5 x .8 x 10mm socket pin type F screw	1	520-1164	520-2031	
F #10-32 x 3/8" spade thumb screw	1	560-1107	560-2107	
G #10-32 x 3/8" serrated washer head socket pin screw	1	520-1151	520-2151	
H #14 x 2.5 phillips hex head wood screw	2	5S1-015-C03	5S1-015-C04	
J .25" ID x .56" OD x .26 spacer	2	590-1050	590-2071	
K #10-32 x 3/8" socket pin screw	2	520-1084	520-2084	
L #10-32 x 3/16" slotted set screw	3	520-1187	520-2187	
M washer	4	540-1025	540-2025	
N M3 x 8 mm serrated washer head socket pin screw	4	510-1004	510-2004	
O M4 x 10mm serrated washer head socket pin screw	4	510-1060	510-2060	
P M5 x 10mm serrated washer head socket pin screw	4	510-1126	510-2063	
R M6 x 10mm serrated washer head socket pin screw	4	510-1066	510-2066	
T 2mm security allen wrench	1	560-1097	560-1097	
U 4mm security allen wrench	1	560-9646	560-9646	
V M5 x 20mm serrated washer head socket pin screw	4	510-1065	510-2065	

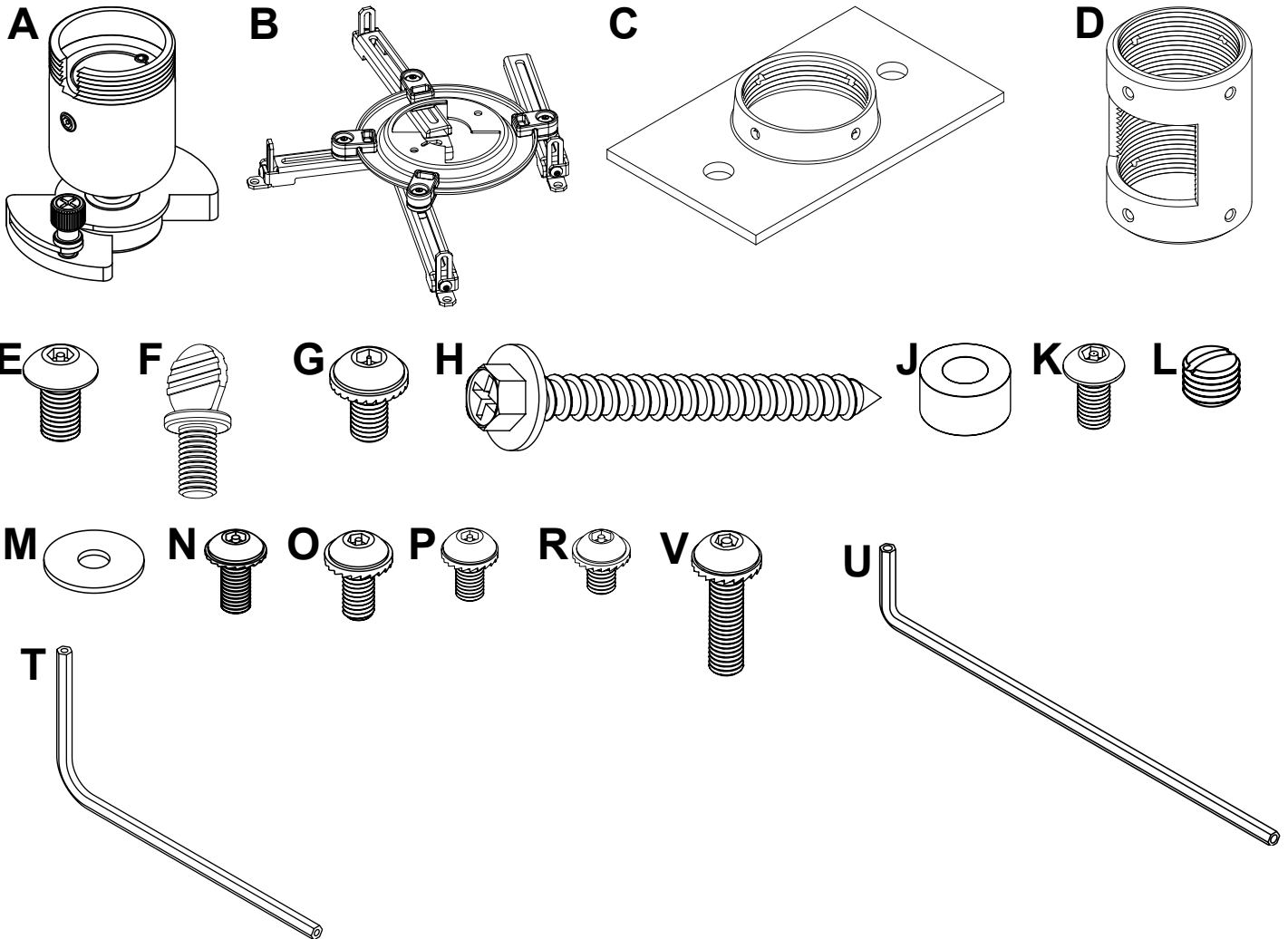

Note: Actual parts may appear slightly different than illustrated.

Installation To Wood Joist Finished Ceilings, Exposed Wood Joists, or Wood Beam Ceilings

⚠ WARNING

- When installing Peerless ceiling mounts on a wood joist/beam covered with gypsum board (drywall), verify that the joists or beams are a minimum of 2" x 4" nominal size. Do not install over gypsum board thicker than 5/8".
- Tighten wood screws (H) so that ceiling plate (C) is firmly attached, but do not overtighten. Overtightening can damage the screws, greatly reducing their holding power.
- Never tighten in excess of 80 in • lb (9 N.M.).
- Make sure that mounting screws are anchored into the center of the studs. The use of an "edge to edge" stud finder is highly recommended.

- 1** Drill two 5/32" (4 mm) dia. holes to a minimum depth of 2.5" (64 mm). Attach ceiling plate (C) with two #14 x 2.5" (6 mm x 65 mm) wood screws (H) as shown using 3/8" (10 mm) socket wrench.

Skip to step 3 for flush mount installation.

Skip to step 4 for extension column installation.

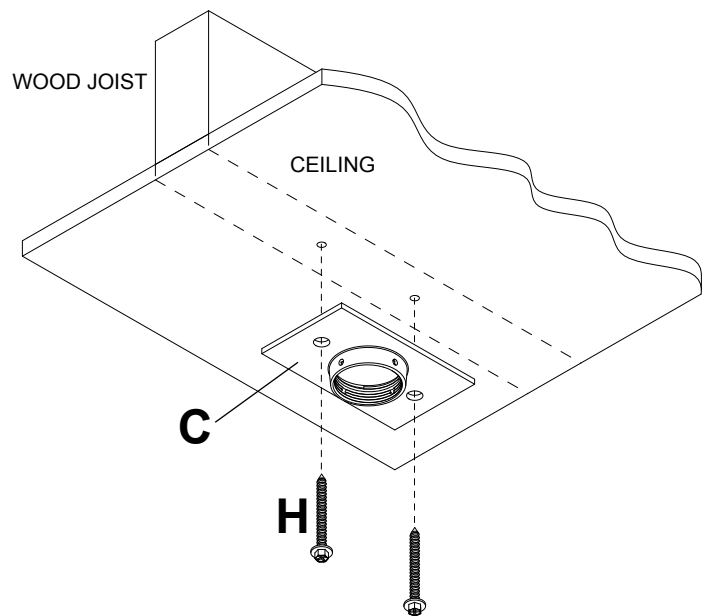

⚠ WARNING

- It is the responsibility of the installer to verify that the supporting surface will safely support the combined load of all attached hardware and components.

IMPORTANT: Be sure to drill holes into the joist CENTER!

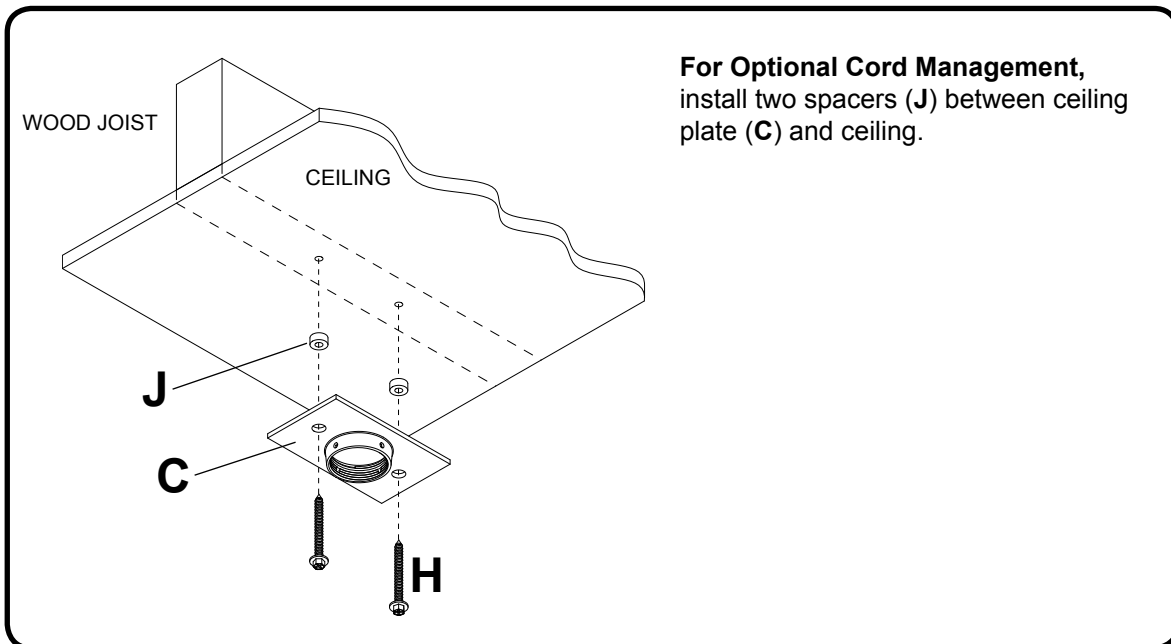

For Optional Cord Management,
install two spacers (J) between ceiling
plate (C) and ceiling.

⚠ WARNING

- When installing Peerless ceiling mounts on a concrete ceiling, the ceiling must be at least 8" thick with a minimum compressive strength of 2000 psi.
- Make sure that the supporting surface will safely support the combined load of the equipment and all attached hardware and components.
- Never exceed the Maximum Load Capacity of 50 lb (27 kg).

Installation to Concrete Ceilings

Use only **PEERLESS ACC233 concrete anchors (sold separately)**.

- 2** Drill two 1/4" (6 mm) dia. holes to a minimum depth of 2.5" (64 mm). Attach ceiling plate (C) using two concrete anchors and #14 x 2.5" wood screws (H) as shown in **Illustration A** and 1, 2, and 3 (below). Tighten all fasteners.

IMPORTANT: It is the responsibility of the installer to verify that the ceiling will safely support the combined load of all attached hardware and components.

Skip to step 3 for flush mount installation.

Skip to step 4 for extension column installation.

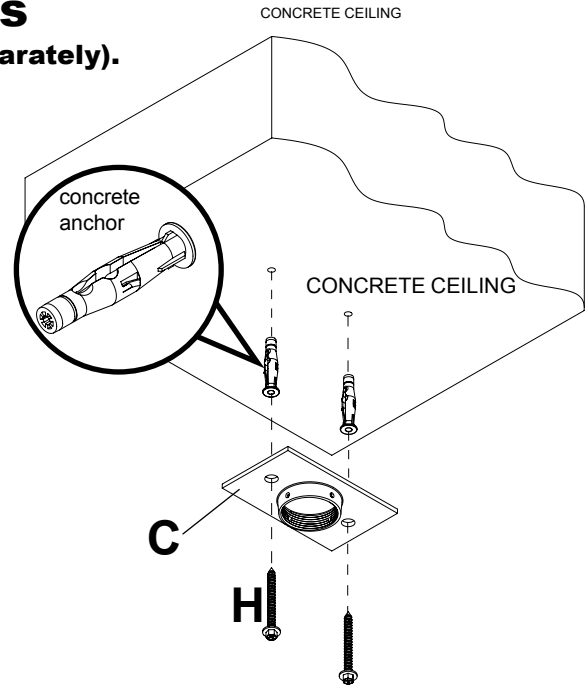

Illustration A

⚠ WARNING

- Tighten wood screws so that ceiling plate is firmly attached, but do not overtighten. Overtightening can damage the screws, greatly reducing their holding power.
- Never tighten in excess of 80 in • lb (9 N.M.).
- Make sure that mounting screws are anchored into the center of the studs. The use of an "edge to edge" stud finder is highly recommended.

⚠ WARNING

- **FOR DIRECT ATTACHMENT TO LOAD BEARING CONCRETE ONLY!** Concrete expansion anchors are **not** intended for attachment to concrete ceilings covered with a layer of plaster, drywall, or other finishing material.

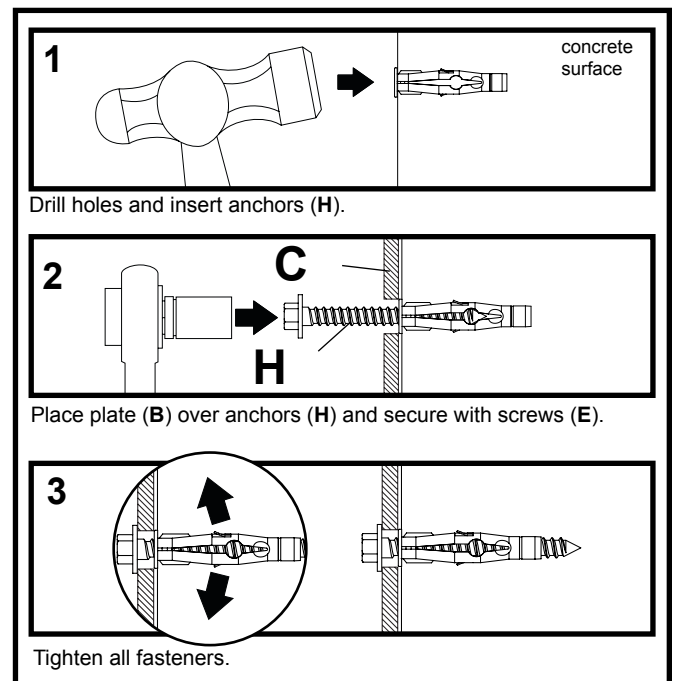

1

concrete surface

Drill holes and insert anchors (H).

2

Place plate (B) over anchors (H) and secure with screws (E).

3

Tighten all fasteners.

Flush Mount Application

- 3** Screw ball and socket mount (A) into ceiling plate (C) as shown in **figure 3.1** (minimum 5 turns). Align the notch with one of the four holes of the ceiling plate (C) and secure ball and socket mount (A) with a M5 x 10 mm socket pin screw (E) using security allen wrench (U) as shown in **figure 3.2**

NOTE: Slotted set screw (L) is used to jam against the threads of the ball and socket mount to prevent any excess movement of the ball and socket mount (A). Do not overtighten screw; overtightening screw will damage threads making it difficult to separate the products.

Skip to step 5.

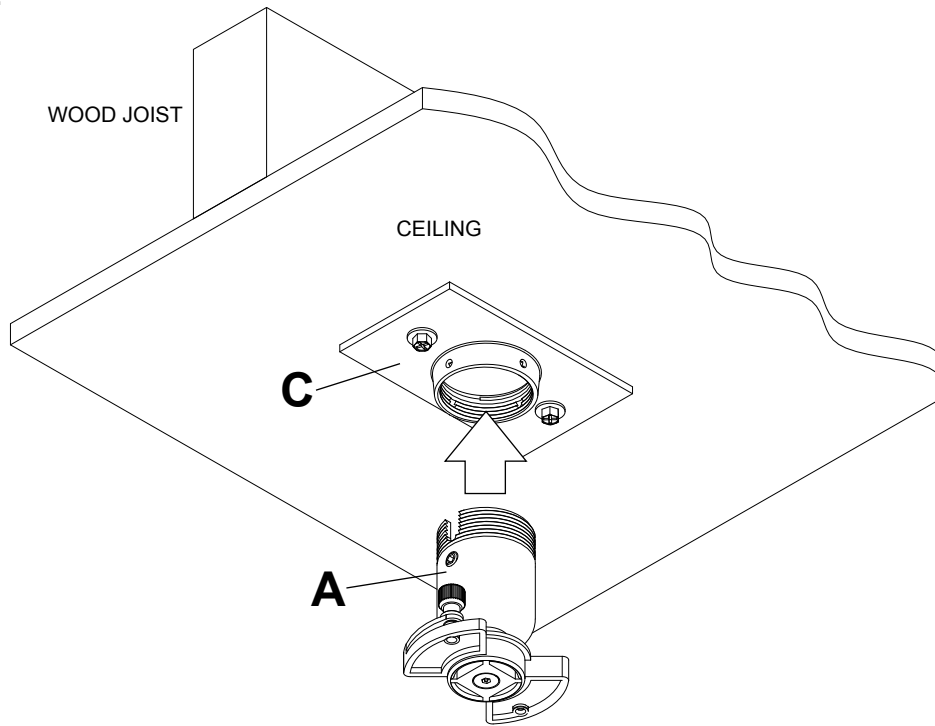

figure 3.1

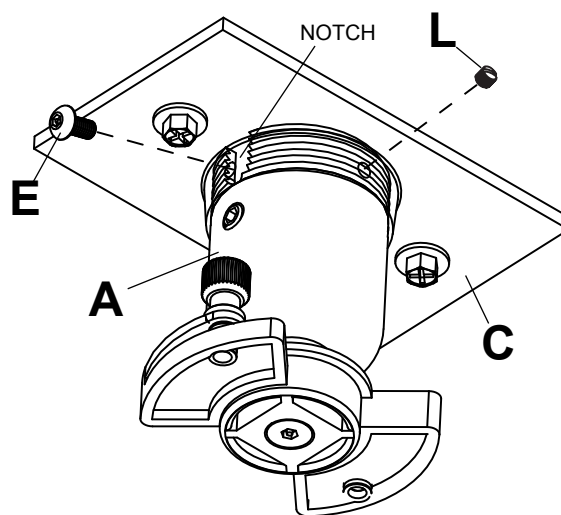

figure 3.2

Installation to Extension Column

4 Screw extension column to ceiling plate (C). Align the notch with one of the four holes in the ceiling plate (C) and secure extension column with a M5 x 10 mm socket pin screw (E) using security allen wrench (U). See figure 4.1

Screw extension column connector (D) to extension column. Align slot in extension column with one of the top holes in extension column connector (D). Insert and tighten one #10-32 x 3/8" socket pin screw (K) through extension column connector (D) into slot on extension column using security allen wrench (U). See figure 4.2

Screw ball and socket mount (A) to extension column connector (D). Align slot in ball and socket mount (A) to one of the bottom holes in extension column connector (D). Insert and tighten one #10-32 x 3/8" socket pin screw (K) through extension column connector into slot in ball and socket mount (A) using security allen wrench (U). See figure 4.3

All pipe thread connections between the ball and socket mount (A), column connector (D), ceiling plate (C) must be threaded a minimum of 5 turns.

Slotted set screws (L) are used to jam against the threads of each connecting joint to prevent any excess movement. Do not overtighten screws; overtightening screws will damage threads making it difficult to separate the products.

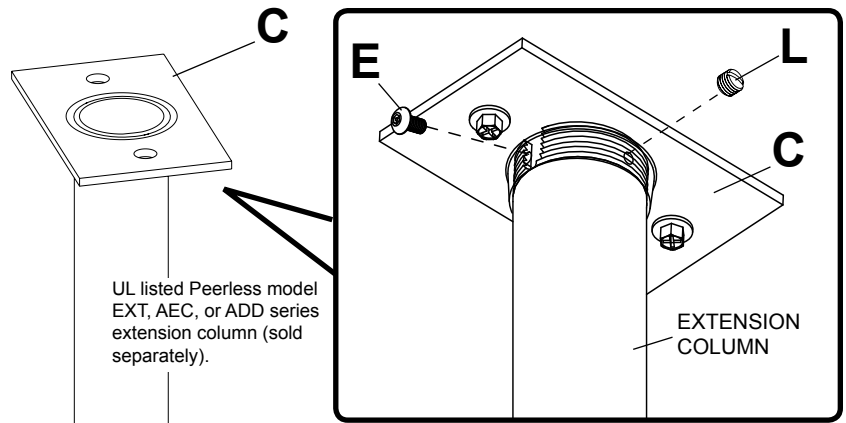

figure 4.1

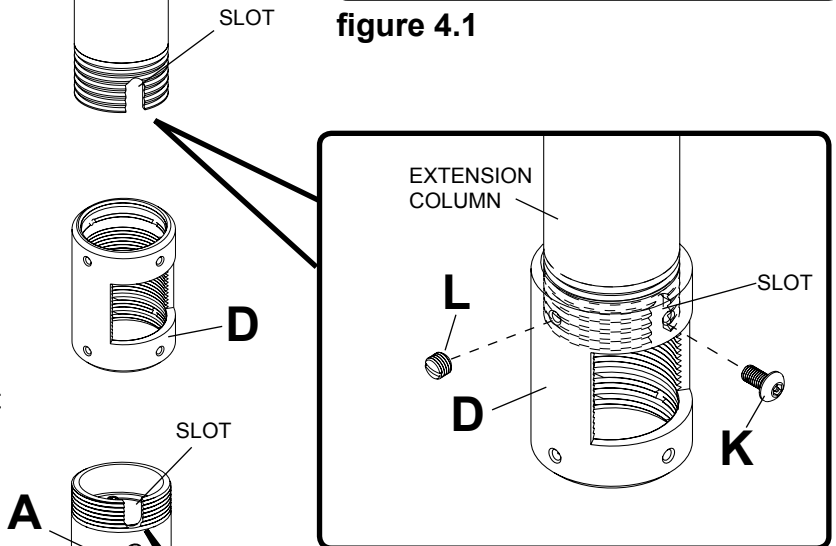

figure 4.2

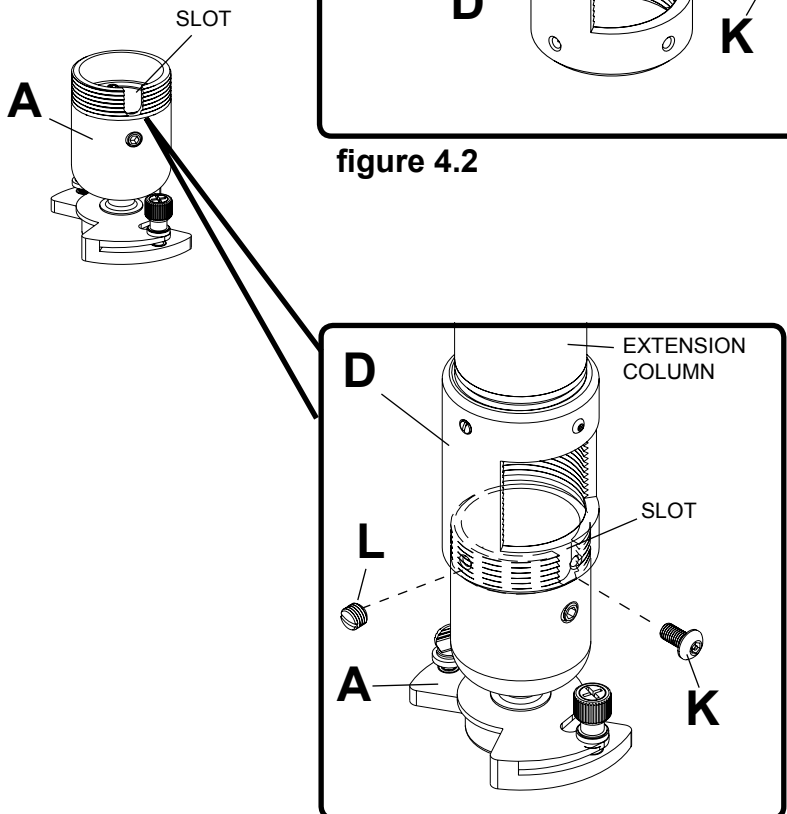

figure 4.3

Attaching Adapter Plate to Projector

NOTE: The projector you are installing may differ in appearance from the sample illustrated below.

- 5** Place projector upside down. Locate adapter plate (**B**) with notch facing forward as close to projector center of gravity as possible without covering any mounting holes. Loosen channels, and if there are only three mounting holes remove fourth channel. Using one channel for each mounting hole, position feet of channels over mounting holes as shown below. **IMPORTANT:** If projector does not have at least three mounting holes, do not use this adapter plate.

NOTE: Some projectors have feet which can be removed and the corresponding threaded insert can be used for a mounting hole.

NOTE: Once channels are in position retighten fasteners.

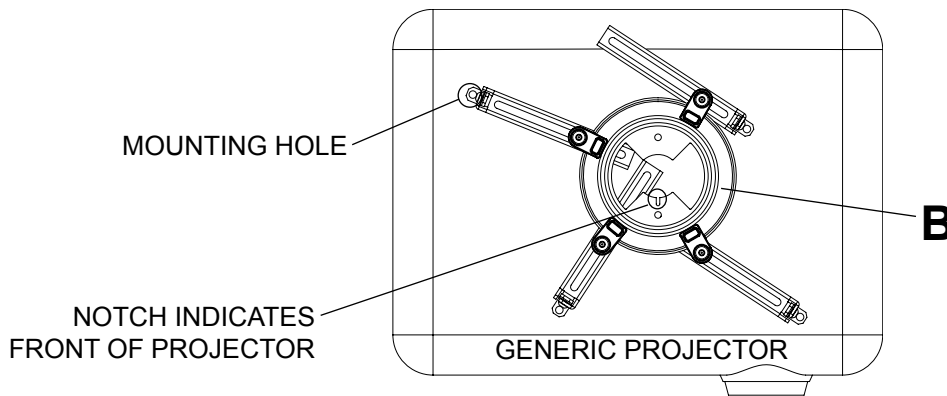

- 6** Attach adapter plate (**B**) to projector using one screw (**N, O, P, R, or V**) for each channel as shown below. Tighten all screws, while keeping the center of gravity. Be sure that adapter plate (**B**) is straight. Adjust the feet of the channels to keep the adapter plate level. Tighten all screws with 4 mm security allen wrench (**U**) or wrench provided with projector mount, while keeping the center of gravity. If M3 screws are used, tighten using 2 mm security allen wrench (**T**).

NOTE: Projectors will require different size screws for mounting. Use a combination of screws (**N, O, P, R, or V**) and foot adjustment that will result in channels of adapter plate (**B**) fitting tightly against projector. **IMPORTANT:** In order to properly engage the threads in the mounting holes, the screw must be turned at least 3 full turns.

Note: If using screw (**N**), place washer (**M**) between screw (**N**) and foot of channel.

CAUTION

- It is the responsibility of the installer to ensure that the projector is properly ventilated. Feet of channels are used to raise the mount off the projector surface.

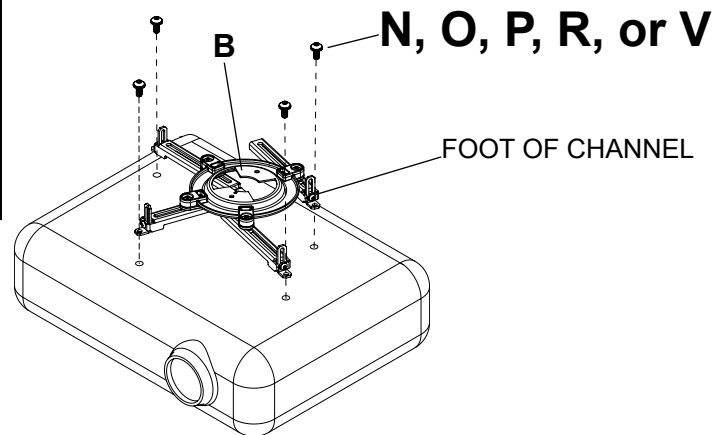

Attaching Adapter Plate to Projector Mount

7 Attach projector, with adapter plate (B) already on it, to the ball and socket mount (A) by inserting the ball and socket mount into the adapter plate connection and twisting until the adapter plate will no longer turn (about 75°). The spring loaded captive screw should line up with a corresponding hole on the adapter plate (this should line up automatically when the two are connected). Push down and tighten the spring loaded captive screw to secure the adapter plate to the mount. If not using the optional security feature, fasten thumb screw (F) in the hole opposite the spring loaded captive screw.

OPTIONAL: For Armor Lock™ security, insert serrated washer head socket pin security screw (G) in the hole opposite the spring loaded captive screw. Tighten with security allen wrench (U). This will prevent the projector from being removed.

NOTE: Be sure to only use the #10-32 x 3/8" screw (G) (or the thumb screw (F)) opposite the spring loaded captive screw.

8 To adjust roll, pitch, and yaw loosen the set screw (shown below) using security allen wrench (U) or standard 4 mm allen wrench. You should be able to just slightly loosen the screw so that your adjustments can be set without having to hold the projector. Move projector to desired position and slowly tighten set screw.

NOTE: Be sure not to touch the projector while tightening the set screw. This may cause the image to be unaligned when you let go.

IMPORTANT: Allen wrench is your key for projector removal. Store it in a safe place.

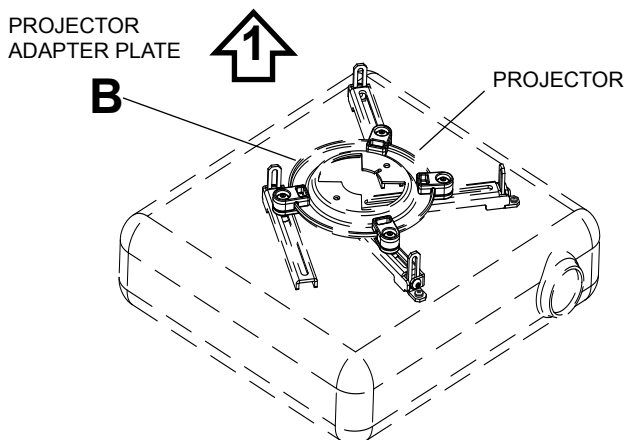
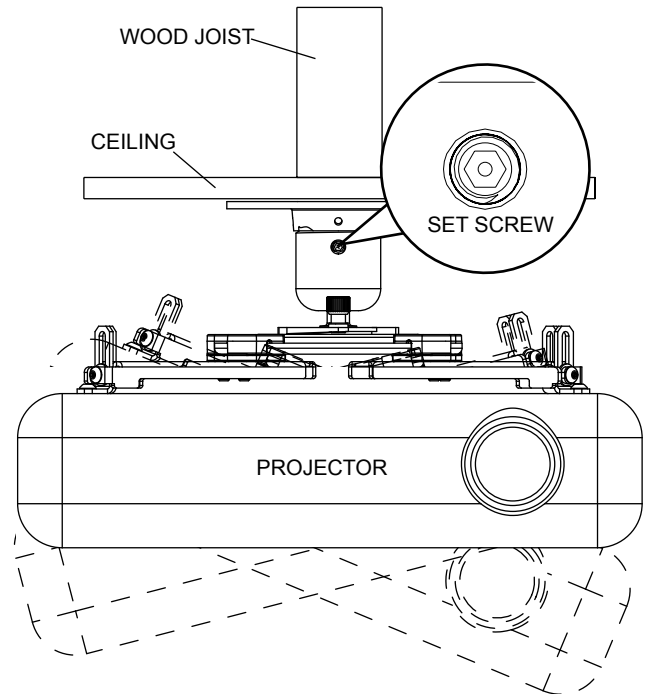
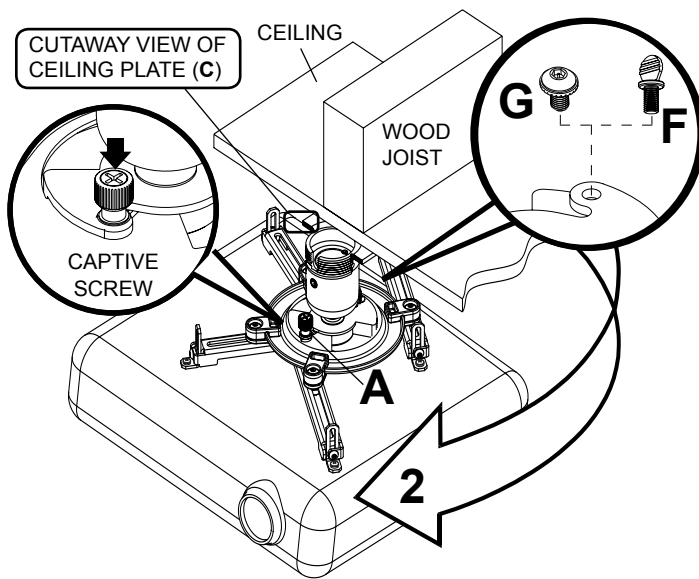

⚠ WARNING

- Do not lift more weight than you can handle! Use additional man power or mechanical lifting equipment to safely handle placement of the projector!