

Technical Manual
Model WMS300
Wall Mount Speaker User Station

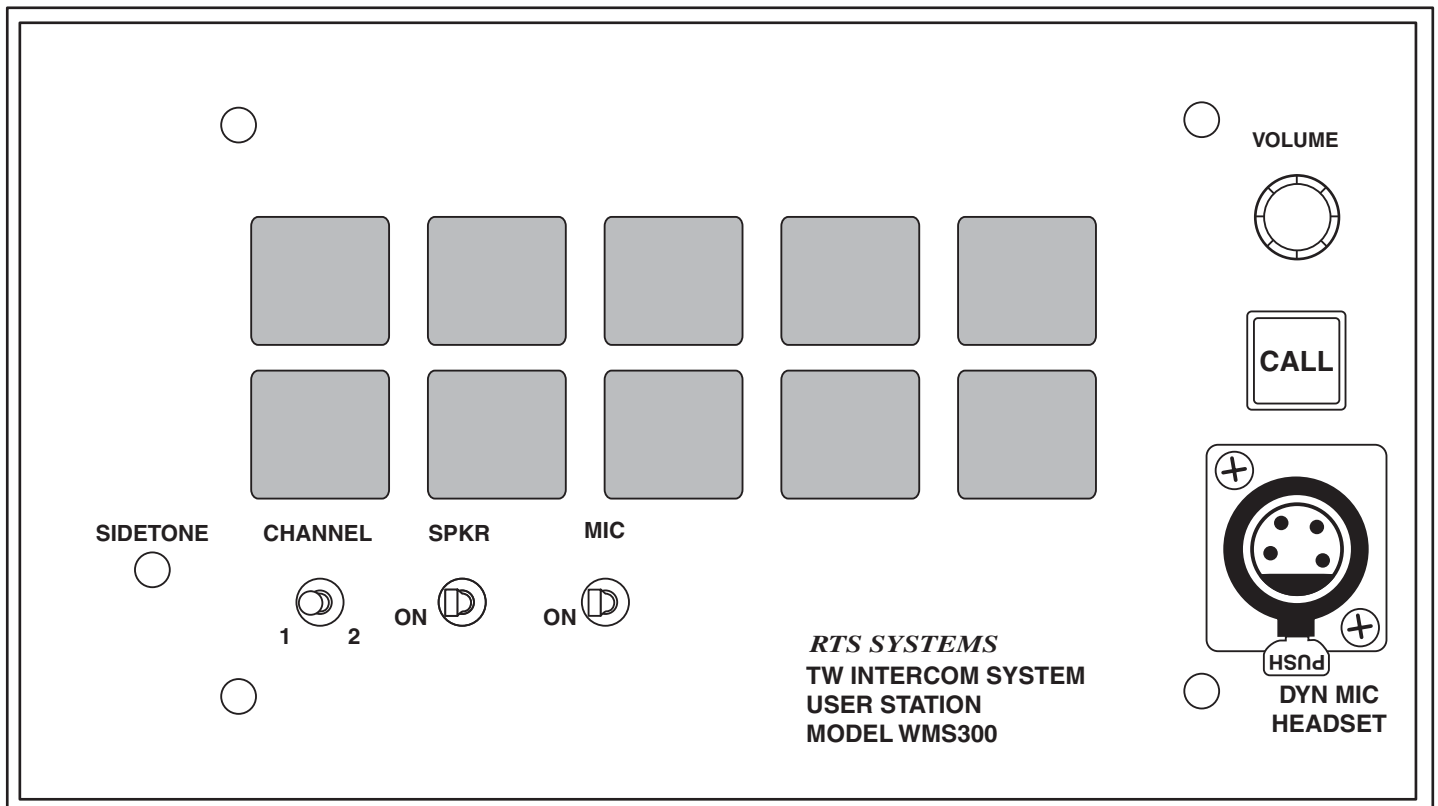

PROPRIETARY NOTICE

The product information and design disclosed herein were originated by and are the property of Telex Communications, Inc. Telex reserves all patent, proprietary design, manufacturing, reproduction, use and sales rights thereto, and to any article disclosed therein, except to the extent rights are expressly granted to others.

COPYRIGHT NOTICE

Copyright 2006 by Telex Communications, Inc. All rights reserved. Reproduction, in whole or in part, without prior written permission from Telex is prohibited.

WARRANTY NOTICE

See the enclosed warranty card for further details.

CUSTOMER SUPPORT

Technical questions should be directed to:

Customer Service Department
RTS/Telex Communications, Inc.
12000 Portland Avenue South
Burnsville, MN 55337 USA
Telephone: 800-392-3497
Fax: 800-323-0498

RETURN SHIPPING INSTRUCTIONS

Customer Service Department
Telex Communications, Inc. (Lincoln, NE)
Telephone: 402-467-5321
Fax: 402-467-3279
Factory Service: 800-553-5992

Please include a note in the box which supplies the company name, address, phone number, a person to contact regarding the repair, the type and quantity of equipment, a description of the problem and the serial number(s).

SHIPPING TO THE MANUFACTURER

All shipments of product should be made via UPS Ground, prepaid (you may request from Factory Service a different shipment method). Any shipment upgrades will be paid by the customer. The equipment should be shipped in the original packing carton. If the original carton is not available, use any suitable container that is rigid and of adequate size. If a substitute container is used, the equipment should be wrapped in paper and surrounded with at least four (4) inches of excelsior or similar shock-absorbing material. All shipments must be sent to the following address and must include the Proof of Purchase for warranty repair. Upon completion of any repair the equipment will be returned via United Parcel Service or specified shipper, collect.

Factory Service Department
Telex Communications, Inc.
8601 East Cornhusker Hwy.
Lincoln, NE 68507 U.S.A.
Attn: Service

This package should include the following:

TABLE OF CONTENTS

PROPRIETARY NOTICE	2
COPYRIGHT NOTICE	2
PATENT NOTICE	2
UNPACKING AND INSPECTION	2
WARRANTY INFORMATION	2
RETURN SHIPPING INSTRUCTIONS	2
SECTION 1; DESCRIPTION AND SPECIFICATIONS	5
1.1 DESCRIPTION	5
1.1.2 OPERATIONAL CONTROLS	5
1.1.3 CONNECTION, INPUTS AND OUTPUTS	5
1.2 MODEL WMS300 SPECIFICATIONS	6
SECTION 2: INSTALLATION	8
2.1 MECHANICAL INSTALLATION	8
2.1.1 HEADSET REQUIREMENTS	8
2.2 ELECTRICAL	8
2.2.1 POWER	8
2.2.2 SIGNAL	8
2.2.3 CROSSTALK CONTROL	8
2.2.4 HUM PREVENTION	9
2.4 USER STATION CONNECTIONS	9
SECTION 3: OPERATION	11
SECTION 7: DRAWINGS	12

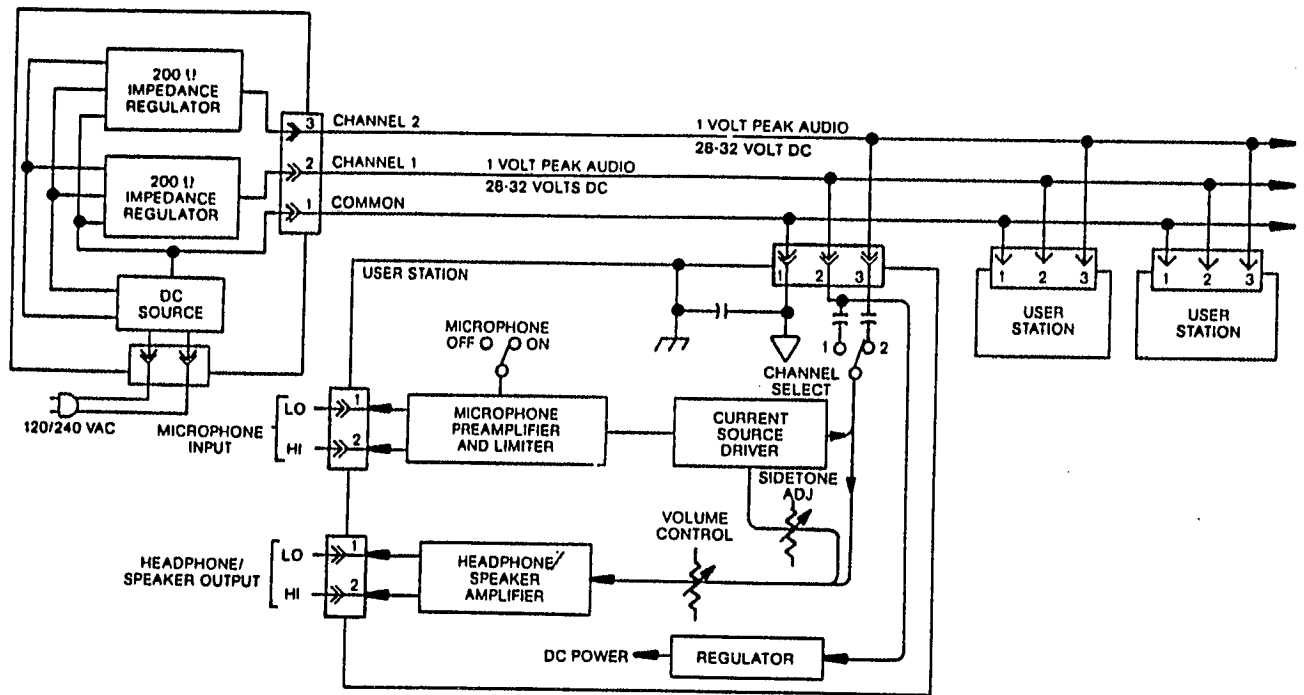

Figure 1-1
TW System Concept Block Diagram

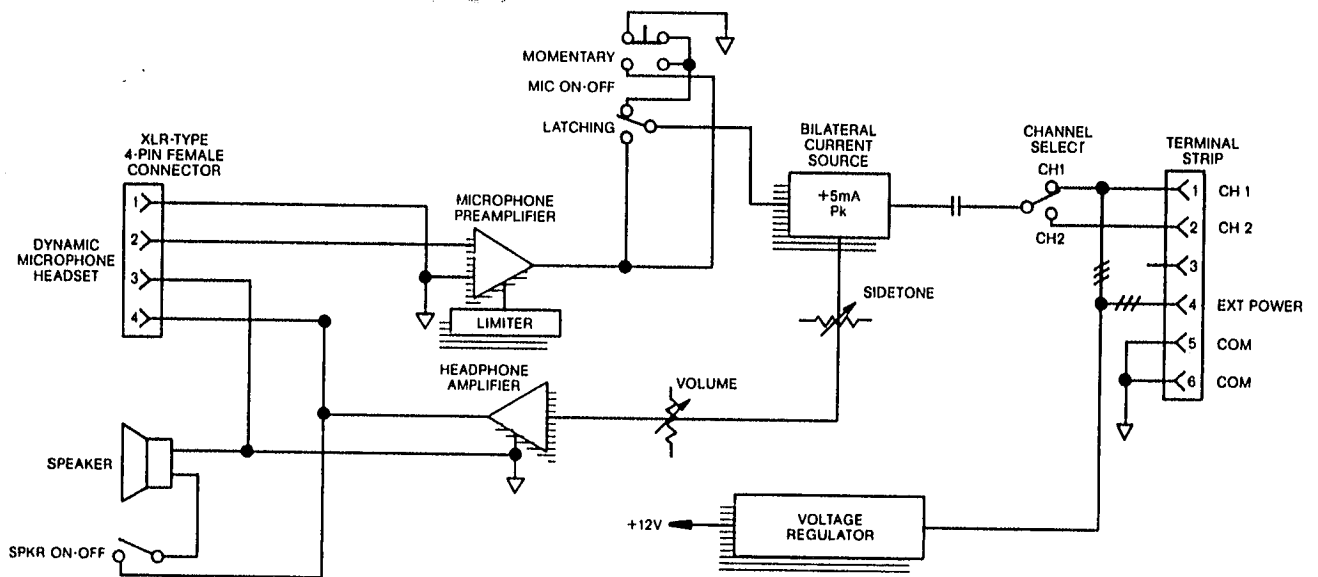

Figure 1-2
WMS300 Block Diagram

SECTION 1: DESCRIPTION & SPECIFICATIONS

1.1 DESCRIPTION

The Model WMS300, a Wall Mount Speaker User Station, is a component used in the TW INTERCOM SYSTEM. Each User Station is a communications unit along a multi-unit conference bus. The System Concept Block Diagram, Figure 1-1, shows User Station interconnection, and User Station connection to the system power supply.

User Station interconnection can be:

- 1) centrally wired, with each cable coming from a central point, or
- 2) distributed, where all the user stations are looped together from one to another, or
- 3) a combination of both. The centrally wired interconnection not only reduces interchannel crosstalk, but also allows for easier expansion into an assignable channel, multi-channel system.

The WMS300 Block Diagram, Figure 1-2, shows user station functional components, input/output connections, and controls. The WMS300 User Station has the following functional components:

- 1) a microphone preamplifier with limiter
- 2) a latching action microphone on/off switch
- 3) a momentary action microphone on/off switch
- 4) a "bilateral current source" line driver
- 5) a listen volume control
- 6) a headphone/speaker amplifier
- 7) a speaker switch
- 8) a channel selector switch

The microphone preamplifier/limiter converts the small microphone signal to a strong line level signal, conditions the signal strength so that loud and soft talkers sound almost the same, and sends the signal to the line via the microphone switch and a "bilateral current source". The bilateral current source adds signal via the channel select switch to the line without affecting any signals already on the line. The bilateral current source also extracts the listen signal from the line and sends it to the headphone amplifier via the volume control. Some of the user's own voice signal ("sidetone") is also fed to the headphone amplifier.

The Channel Selector Switch selects the channel on which the user will talk and listen. The headphone amplifier output drives the user's headphones speaker and the speaker through the on/off switch.

The Volume Control adjusts Listen Level of the headphones and speaker. Note: The headphones are always "on"..

The user station voltage regulator takes power from channel 1, regardless of the channel selector switch setting

(exception: local power option units). The regulator not only supplies regulated power to the user station, but also prevents unwanted interaction between the user station and that intercom line which is supplying the power. Because the regulator takes power from channel 1, channel 2 can be expanded into many channels by using a switch and, for each channel, a separate wire and a termination network consisting of a 200 ohm resistor and a 10 microfarad capacitor in series. (See the Application Diagrams in the TW Intercom Systems Technical Manual). A TW System Power Supply terminates each channel line with 200 ohms.

1.1.2 Operational Controls

The WMS300 User Station has the following controls, described and shown in Section 3.1:

- 1) Channel Select Switch
- 2) Latching-action MICROPHONE ON-OFF toggle switch.
- 3) Momentary-action MICROPHONE ON-OFF pushbutton switch (not standard with the call-light option).
- 4) A speaker/headphone VOLUME control (May be a dual control for the Dual Listen (DL) Option or the Program (E) Option
- 5) CALL LIGHT switch/indicator (Call Light Option (-L)
- 6) SPeAKeR ON/OFF switch
- 7) SIDETONE Adjustment

1.1.3 Connection, Inputs and Outputs

The WMS300 User Station has two input/output connectors described in Section 2.4:

- 1) DYNAmic MICROPHONE type HeADSeT or handset
- 2) Line INPUT (ties the station to the intercom line)

1.2 MODEL WMS300 SPECIFICATIONS

Input DC voltage:	20 to 35 volts DC, operating from -200 to +36 volts DC without damage
DC Current	
Quiescent	10 to 40 milliamps
Operating	50 milliamps, typical (w/25 ohm headphones) 75 milliamps, typical (w/25 ohm headphones + light) 100 milliamps, typical(w/8 ohm speaker)
Impedance across line:	10,000 ohms typical
Ambient Temperature Range	Operating: 0°C to 60°C Storage: -55°C to 125°C
Noise contribution to 200 ohm line:	One Unit: -75 dBu Ten Unit: -67 dBu
Microphone Preamplifier	
Input impedance*	470 ohms
Source Impedance*	200 ohms, nominal
Maximum Input Level*	150 millivolts
Voltage gain:	54 dB
Frequency Response	100 Hz to 10,000 Hz, ± 3 dB
Limiter range	30 dB
Carbon Mic Excitation Current	10 milliamps, nominal (when optioned for Carbon Mic)
*Dynamic Microphone Input	
Current Source	
Transfer ratio:	5 milliamps / 1.5 volts
Output:	± 5 milliamps into 200 ohms
Headphone Amplifier	
Voltage gain	34 dB
Output voltage	9 volts peak-to-peak into 25 ohms
Output power:	Headset station: 1/2 watt into 25 ohms Speaker Station: 2 watts into 8 ohms
Frequency Response	150 Hz to 8,000 Hz, ± 3 dB
Headphone Impedance Range	25 to 600 ohms
Sidetone Adjustment Range	20 dB to full on
Call Light:	Signaling Frequency 20,000 Hz \pm 100 Hz Flashing Rate 5 Hz \pm 2 Hz
Dimensions	4.5" H \times 8.0" W \times 2.25" D 114.3 mm \times 203.2 mm \times 57.2 mm

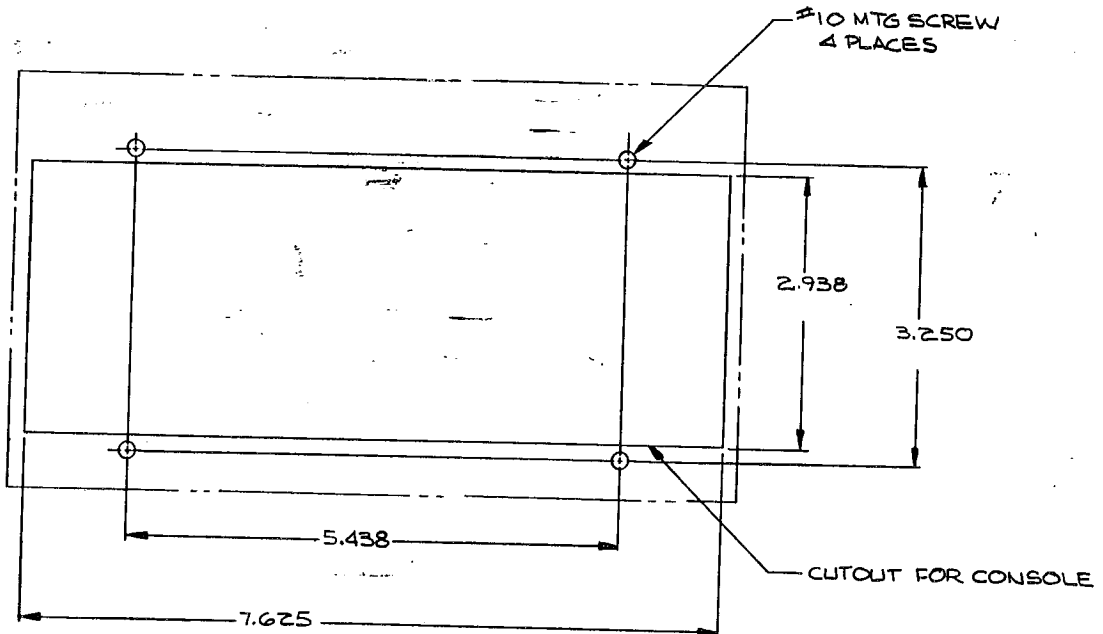
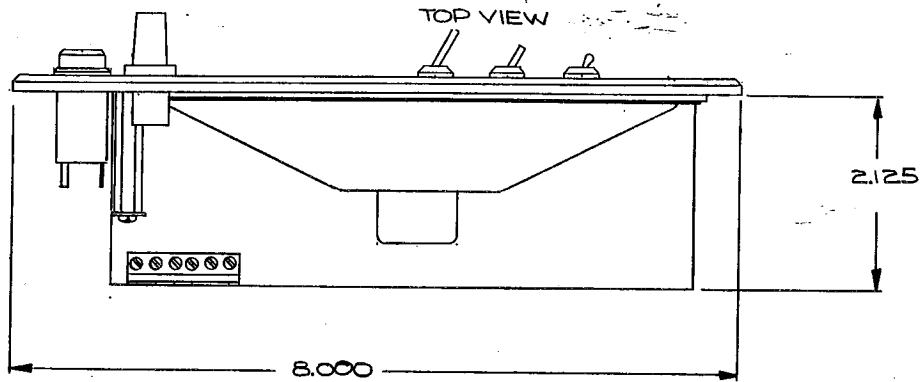
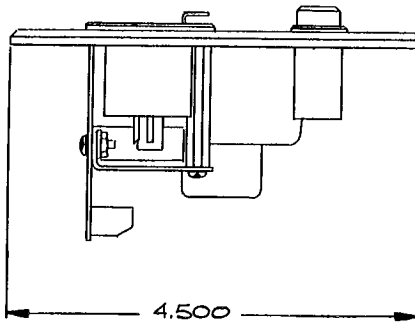

Figure 2-1
WMS300 Installation Diagram

SECTION 2: INSTALLATION

2.1 MECHANICAL INSTALLATION

The Model WMS300 is designed to fit into an 8-gang standard electrical conduit box, 2.25 inches deep (57.2 mm). See Figure 2-1, WMS300 Installation Drawing for additional mechanical installation information.

When installing this station, allow space for control access, cabling and servicing. Provide space for: cabling service loops, reaching AXR type connector lock releases, and headset connectors/cables. If the headset connector is remotely located, allow space between this cable and interfering sources such as video/TV monitors, power supplies and equipment with internal power supplies. There are no ventilation requirements.

2.1.1 Headset Requirements

Dynamic microphone headset type:

50 to 1000 ohm microphone
25 to 1000 ohm headphone(s)

High efficiency headphones are recommended because less line current is required from the power supply. Use headphones with an impedance of 25 ohms or greater. Low impedance 8 ohm headphones are not recommended. Headphones with good acoustic isolation (20 to 40dB) improve communication in high ambient noise environments, and allow the user to use the headphones at a less tiring, lower volume.

In the headset connecting cable, prevent coupling between the microphone and headphone leads by using a shielded, twisted pair for the microphone, and a separate, twisted pair for the headphones. Do not allow headphone ground to contact microphone ground or shield. Tie the shield to microphone ground or "mic low". The headset cable can be made longer when the microphone and headphone pairs are physically separated. The wider the separation, the longer the cable length which may be used. Estimated maximum usable headphone cable lengths are as follows:

Single cable, 2 shielded twisted pair: 10 ft (3 m)
Dual ribbed cable, 2 shielded twisted pair: 30 ft (9 m)
Separate cables, shielded twisted pair in each: 50 ft (15.24 m)
Balanced microphone input: up to 100 feet (30.48 m)

2.2 ELECTRICAL

2.2.1 Power

The WMS300 receives electrical power from either:

(1) a system power supply (26 to 32 volts DC on line connector pins 2 (+) and 1 (com) (two channel operation); or

(2) a local power supply option (12 to 18 volts DC). A user station requires 18 to 33 volts to be a 10,000 ohm bridging impedance across the powering line, but the station can otherwise operate (as in the local power option) from 12 to 33 volts.

Model WMS300 current requirements range from 30 to 100 mA, and WMS300-L from 40 to 150 mA; Since, in (1), above, the power and communications signals may share conductors, it may be necessary to overcome power losses by increasing conductor size over long runs (over 1/2 mile (804 m)). Typical operating distance for one WMS300 station is 1/2 mile (.80 km), and for one WMS300-L, 1/3 mile (0.53 km) using a normal #22 AWG conductor size.

2.2.2 Signal

The required number of conductors to interconnect user stations is as follows (For standard unbalanced TW user stations):

<u># of Channels</u>	<u># of Conductors</u>
1	2
2	3
3	4

Use shielded cable to interconnect user stations in areas of possible electrical interference, (areas such as those near: digital equipment, high current primary power conductors ("mains"), transformers, transmitters, and lamp dimmers).

Most two channel applications may use either standard microphone cable (for convenience) or two-twisted-pair cable (considerably less expensive than microphone cable). Standard wire size for the TW Intercom System is #22 gauge wire for interconnection.

For permanent installations it is recommended that each channel should have individually shielded twisted pair of at least #22 gauge wire, such as Belden #8723 for 2 channels. Connect the shield to system common but do not tie the shield to chassis, earth or connector shell ground.

2.2.3 Crosstalk Control

In the TW Intercom System all channels share a common circuit ground return. Crosstalk due to common ground resistance can be lowered by reducing the common ground resistance. Reduction of ground resistance can occur as a side benefit of using shielded cable, since the shield drains can be tied together and electrically parallel the circuit ground. Another way of lowering resistive crosstalk is to "homerun" all interconnecting cables to a central or "home" location. In this configuration, the ground path is short and the corresponding ground resistance is small. Crosstalk due to mutual capacitance occurs when the signal on one wire of a twisted pair couples into the other wire.

Separating the two conductors with a shield greatly reduces the capacitive crosstalk.

To reduce both capacitive and resistive crosstalk and to afford a degree of RF and electrostatic shielding, use a cable which has a shielded twisted pair for each channel. Each pair consists of a conductor for the channel, a conductor for circuit ground return and a shield around the two conductors. The shield is accessed via a drain conductor. This drain conductor and the shield can augment the circuit grounds and thus lower the ground resistance.

Routing the TW Intercom System cables along the same ductways and pathways as power cabling can increase the noise and hum levels.

2.2.4 Hum Prevention

Prevent inducing hum into the system by not locating user stations near hum sources such as power transformers, electrical switch panels, lamp dimmers or TV cameras. When the microphone switch is turned on, the dynamic microphone acts as a sensitive antenna for hum sources.

2.4 USER STATION CONNECTIONS

Dynamic Microphone headset connector:

AXR-4-31 type receptacle (J1)

Input level: -55 dbu nominal

Output level to headphone: 10 volts peak-to-peak open circuit.

- Pin 1 - Microphone low
- Pin 2 - Microphone high
- Pin 3 - Headphone low
- Pin 4 - Headphone high

Line input connectors: (TB1)

- Terminal # 1 - Channel 1
- Terminal #2 - Channel 2
- Terminal #3 - Channel 3 (3CH option)
- Terminal #4 - Ext Power In (LP option)
- Terminal #5 - Common (low side of line)
- Terminal #6 - Common (low side of line)

USM option:

- Terminal #4 - USM High
- Terminal #5 - USM Low

INSTALLATION, LOCAL POWER OPTION, WMS300

The WMS300 can be powered from an external (local) power supply of between 18 to 33 volts DC. The local power option, as supplied by RTS Systems uses a 117 VAC 60 Hz in, 24 VDC 400mA out supply. The external supply is wired across terminal block, TB1 pins 4 (external power +) and 5 (common). When using an external supply, the circuit board trace running between TB1 pins 1 (channel 1) and 4 must be cut.

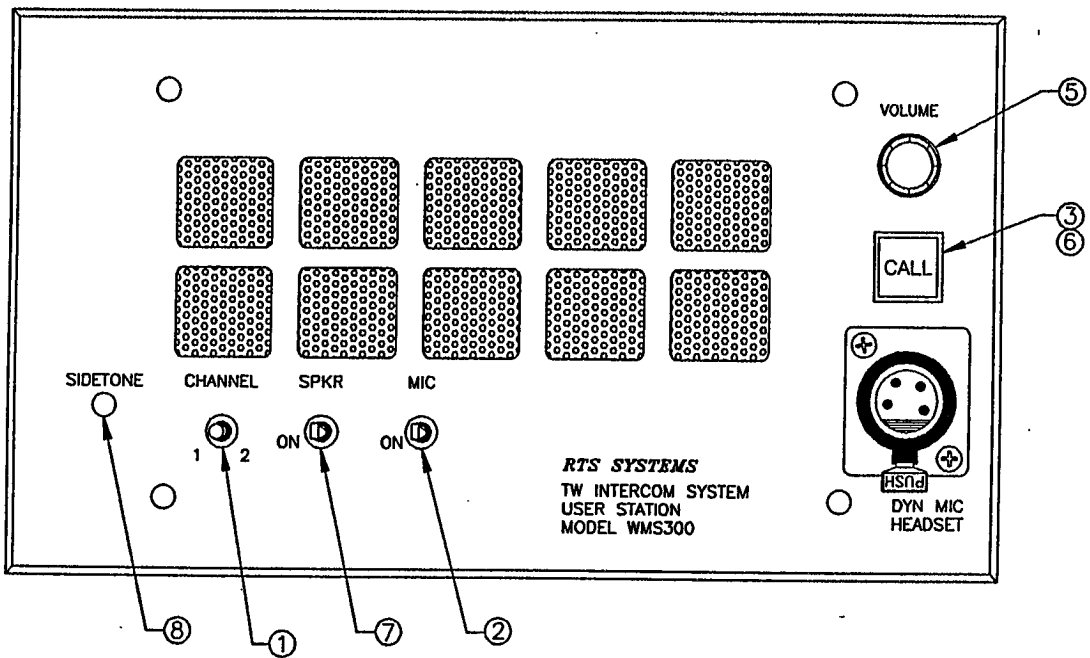

Figure 3-1
Model WMS300 Front Panel

SECTION 3: OPERATION /Operating Controls (See Figure 3-1)

Table 3-1 lists the Model WMS300 operating controls, with reference numbers corresponding to Figure 3-1.

<u>Ref No.</u>	<u>Name</u>	<u>Description</u>
1	Channel Select Switch	Selects one of two channels (standard) or one of three channels (optional). The Call Light Option transmitter and receiver operate on the channel selected by this switch. The CHannel Select Switch is omitted in the Single Channel (SC) option.
2	MIC ON-OFF Toggle	A latching-action switch.
3	MIC ON-OFF Pushbutton	A momentary-action pushbutton switch. Not standard with the Call Light Option. Turning on the microphone here also slightly "dims" or attenuates the speaker.
4	MIC SWITCH	A momentary MIC switch is located on the optional push-to-talk microphone and requires that 2) above is ON. The push-to-talk microphone schematic is included in the speaker station schematic.
5	VOLUME	A speaker/headphone volume control. May be a dual control for the Dual Listen (DL) or Program (E) Option.

CAUTION: ALWAYS TURN THIS CONTROL ALL THE WAY COUNTERCLOCKWISE (TO THE LEFT) BEFORE PLUGGING IN THE HEADSET.

6	CALL Light Switch Indicator	This switch/indicator appears only on the user stations with the "Call Light" option. When the CALL Switch is depressed, a 20 kilohertz signal is added to the TW intercom line on the same channel that the CHannel Select Switch has been set. This signal activates the Call Light receiver on all user stations which are switched to the same channel.
7	SPeaKeR ON/OFF	This switch turns on the speaker.
8	SIDETONE	The screwdriver-adjusted SIDETONE control sets the "sidetone" level during headset operation and sets the "balance" nulling during speaker/panel microphone operation.

To adjust the SIDETONE control for speaker operation:

1) turn ON the SPeaKeR switch, 2) turn ON the MICrophone switch, 3) set the VOLUME control to about 50%, 4) plug in a microphone 5) hum into the microphone and adjust SIDETONE for minimum sound through the loudspeaker.

To adjust the SIDETONE control for headset operation:

1) turn OFF the SPeaKeR switch, 2) turn ON the MICrophone switch, and 3) plug in a headset, 4) set the VOLUME control to about 50%, 5) turn the SIDETONE control fully counterclockwise, the adjust it clockwise for a comfortable level of your own voice while talking into the headset microphone.

SECTION 7: DRAWINGS

RTS Systems

Document

Number

Title

SD3487	Servicing Diagram, Light Signaling Circuit CC28
AS5079	Assembly Diagram, CC303 - 2nd Gen
SD2387	Schematic Diagram, WMS300/WMS300-L, Sheet 1 of 2
SD2387	Schematic Diagram, WMS300/WMS300-L, Sheet 2 of 2

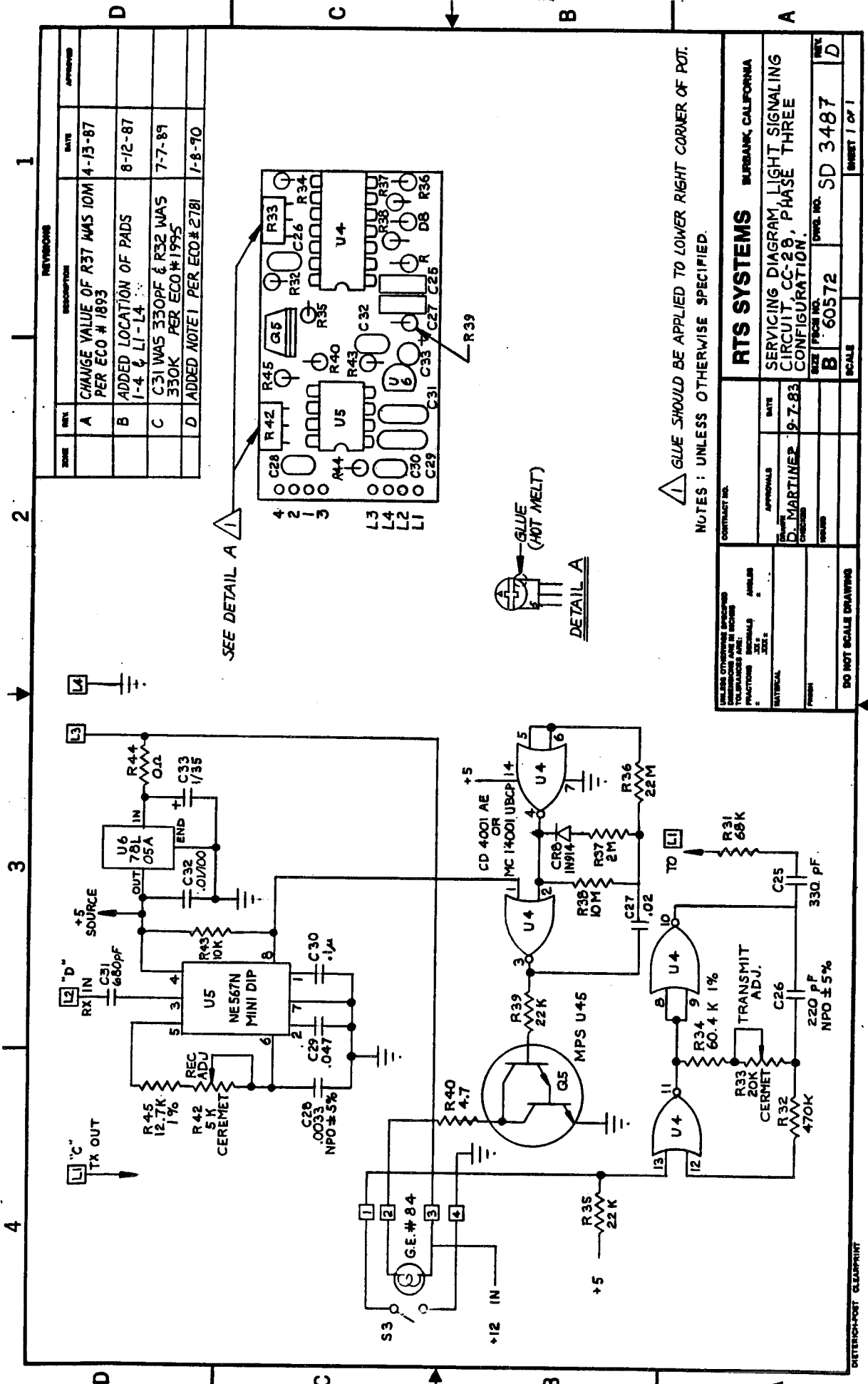

REV	DESCRIPTION	DATE	APPROVED
A	CHANGE VALUE OF R37 WAS 10M PER ECO # 1895	4-13-87	
B	ADDED LOCATION OF PADS 1-4 & L1-L4	8-12-87	
C	C31 WAS 330PF & R32 WAS 330K PER ECO # 1995	7-7-89	
D	ADDED NOTE 1 PER ECO # 2781	1-8-90	

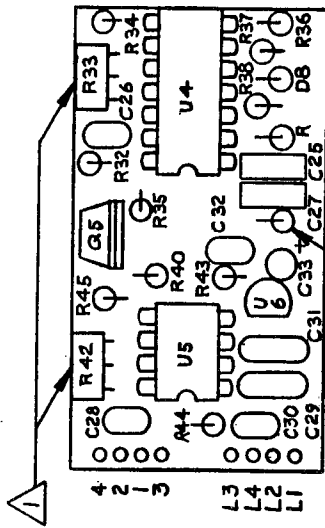

⚠ GLUE SHOULD BE APPLIED TO LOWER RIGHT CORNER OF POT.
 NOTES: UNLESS OTHERWISE SPECIFIED.

CONTRACT NO.		DATE	
APPROVALS		DATE	
DESIGNED BY	D. MARTINER	9-7-83	
CHECKED BY			
ISSUED BY			
PARTIAL		DO NOT SCALE DRAWING	
ALL DIMENSIONS UNLESS OTHERWISE SPECIFIED ARE IN INCHES FRACTIONS DECIMALS ANGLES TOLERANCES ARE: .001" .005" .010" .020" .030" .040" .050" .060" .070" .080" .090" .100" .125" .150" .175" .200" .250" .300" .375" .500" .625" .750" .875" 1.000"		RTS SYSTEMS BURSANK, CALIFORNIA SERVICING DIAGRAM LIGHT SIGNALING CIRCUIT CC-28, PHASE THREE CONFIGURATION.	
DRAWING NO.		DWG. NO.	
B 60572		SD 3487	
SCALE		SHEET 1 OF 1	

DIETERNICH-POST CLEARPRINT

REVISIONS		DATE	APPROVED
ZONE/REV	DESCRIPTION		
B	REVISED AND REDRAWN PER ECO#3288	2/5/91	RTC
C	DELETED NOTE 2 PER ECO#3402	4/19/91	RTC

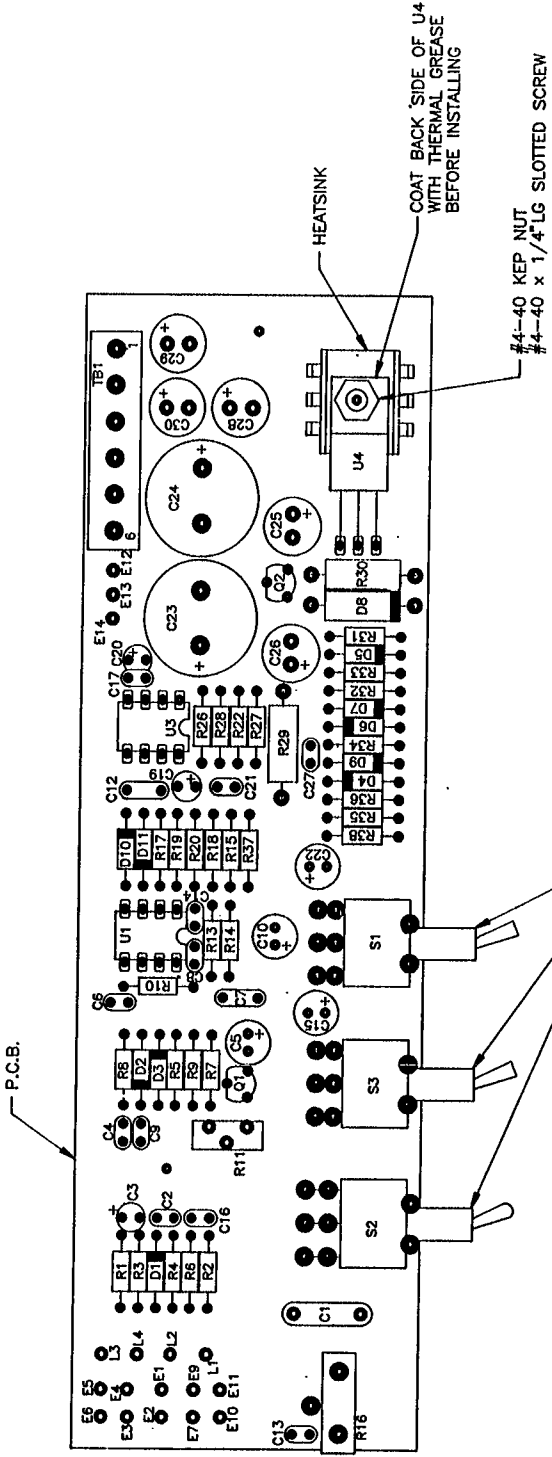

- FOR PART NO'S AND DESCRIPTIONS SEE SEPARATE PARTS LIST 9030-5079-00.
 - NOTE REMOVED
 - ITEMS C2,C12,C16,C30,D1,R2,R4,R29,R38 ARE NOT INSTALLED AT THIS LEVEL (OPTIONAL). SEE SCHEMATIC DIAGRAM SD2387.
- Ⓢ DO NOT INSTALL S1-S3 AT THIS LEVEL.
 NOTES: UNLESS OTHERWISE SPECIFIED

CONTRACT NO.		APPROVALS		DATE
UNLESS OTHERWISE SPECIFIED REMOVE ALL BARRS & BREAK SHARP EDGES		DRAWN		2/5/91
MALE TERMINALS PER MIL-STD-883C		CHECKED		
DIMENSIONS ARE IN INCHES		ISSUED		
DIMENSIONS ARE IN MILLIMETERS		MATERIAL		
RESISTORS ARE: 1% TOL		FINISH		
CAPACITORS ARE: 5% TOL		NEXT ASSY		
INDUCTORS ARE: 5% TOL		USED ON		
DIODES ARE: 1% TOL		APPLICATION		
IC'S ARE: 1% TOL				
TRANSISTORS ARE: 1% TOL				
RELAYS ARE: 1% TOL				
CONNECTORS ARE: 1% TOL				
WASHERS ARE: 1% TOL				
SCREWS ARE: 1% TOL				
NUTS ARE: 1% TOL				
SPRINGS ARE: 1% TOL				
OTHER PARTS ARE: 1% TOL				
MATERIAL				
FINISH				
NEXT ASSY				
USED ON				
APPLICATION				
RTS SYSTEMS		BURBANK, CALIFORNIA, USA		
ASSEMBLY DRAWING- P.C.B., CC303-2nd GEN., WMS300		SCALE 2/1		
SIZE ESCM NO. DWG NO. AS5079		REV C		
C160572		AS079C01.DWG		
SHEET 1 OF 1				

Zone	Rev	Description	Date	Apprv
	K	REVISED & REDRAWN	8-2-89	
	L	ADD FLAG NOTE 20 ECD# 55306 MJL	3-23-92	KCF
	M	CHG LOCATION OF [20], 3 PLS; ECD # 5591	1 JULY 92	DE-912

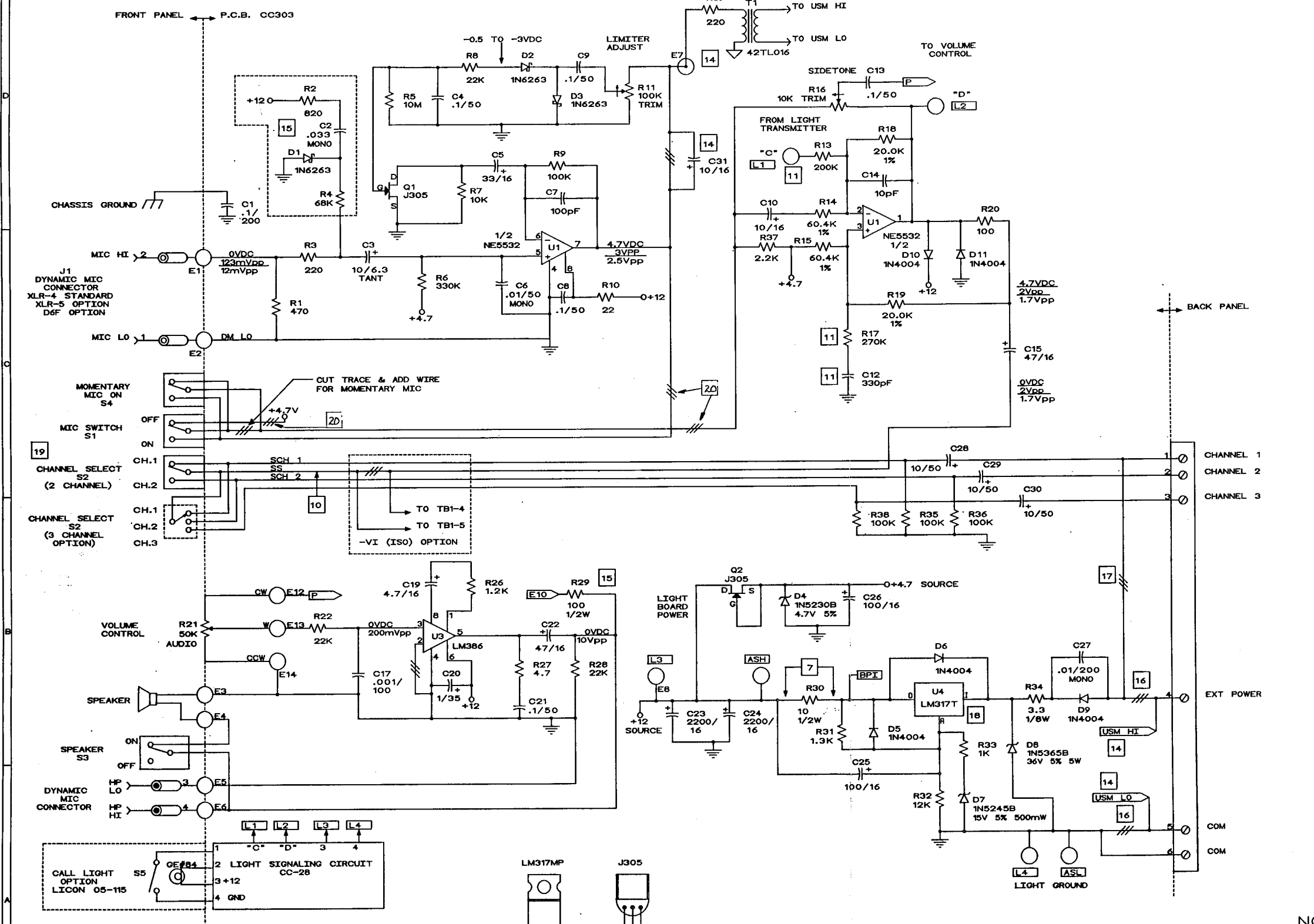

- 20 CUT TRACES FOR *V (MIC CONTROL OPTION)
- 19 FOR SINGLE CHANNEL OPTION (OPTION CODE "Z"), REMOVE S2 & JUMPER SS TO SCH 1.
- 18 U4 IS LM317MP ON 1st GENERATION UNITS.
- 17 CUT TRACE FOR LOCAL POWER OPTION.
- 16 CUT TRACE FOR USMB, VI OPTIONS.
- 15 APPLIES TO CARBON MIC OPTION.
- 14 APPLIES TO UNSWITCHED BALANCED MIC OUT (USMB) OPTION.
- 13. ∇ = SCHOTTKY DIODE, $V_f \approx 0.1$ TO $0.3V$.
- 12. THIS DRAWING DERIVED FROM SD1464, REV E.
- 11. ADD FOR CALL LIGHT (L) OPTION.
- 10. CALL LIGHT OPTION TEST DATA: $20.000 \pm 0.000KHZ$ AT $10Vpp$ MEASURED AT THIS POINT. USE TEST JIG BELOW.
- 9. TEST JIG AND TEST SET UP FOR VOLTAGE READINGS. SET CHANNEL SELECT FOR CHANNEL 2.

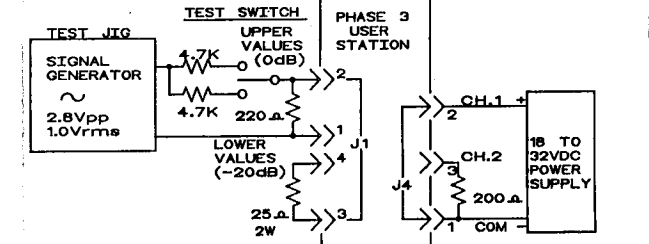

- SET FREQUENCY TO 1kHz, TEST SWITCH IN 0db, POSITION AND VOLUME POT AT MIN. ADJUST LIMITER POT FOR 2Vpp AT J4 PIN 3. TEST FREQUENCIES: 100Hz, 1kHz, 10Hz, (+/- 3db).
- 8. ALL TEST VOLTAGES AND CURRENTS: +/- 10%.
 - 7. QUIESCENT CURRENT: 17mA (NO "L" OPTION) QUIESCENT CURRENT: 27mA (WITH "L" OPTION) DYNAMIC CURRENT: 20 TO 40mA ADDITIONAL.
 - 6. OPTIONS AND MNEMONICS ARE EXPLAINED IN THE OPTION LIST, AND ON OPTION DETAIL SHEET.
 - 5. CUTTABLE TRACES (USED FOR OPTIONS) ARE SHOWN: ∇ .
 - 4. THIS DRAWING APPLIES TO THE FOLLOWING USER STATION OPTIONS: XL5, D6F, LLLP, 3CH, USMB, -VI, SC(Z).
 - 3. THIS DRAWING APPLIES TO THE FOLLOWING USER STATION MODEL NUMBERS: WMS300 & WMS300-L.
 - 2. CAP. VALUES ARE SHOWN: MICROFARADS/VOLTS.
 - 1. ALL RESISTORS ARE CARBON FILM, 1/4W, 5%.

NOTES: UNLESS OTHERWISE SPECIFIED

CONTRACT NO. TW SYSTEM		RTS SYSTEMS Burbank, California	
Drawn	R. NELSON	SCHEMATIC DIAGRAM, WALL MOUNT USER STATION, MODELS WMS300 & WMS300-L	
Checked	W. K. B. H. G.	SIZE	F5CM DWG NO
Issued		DATE	8-7-89 S2387K01
		60572	SD2387
		DATE	8-7-89 S2387K01

LAST USED: C31, D11, Q2, R39, S3, U4
 NOT USED: C11, C18, R12, R23, R24, R25, U2



