

*MODEL BP-325*  
*Belt-pack Intercom Station*  
*User Manual*

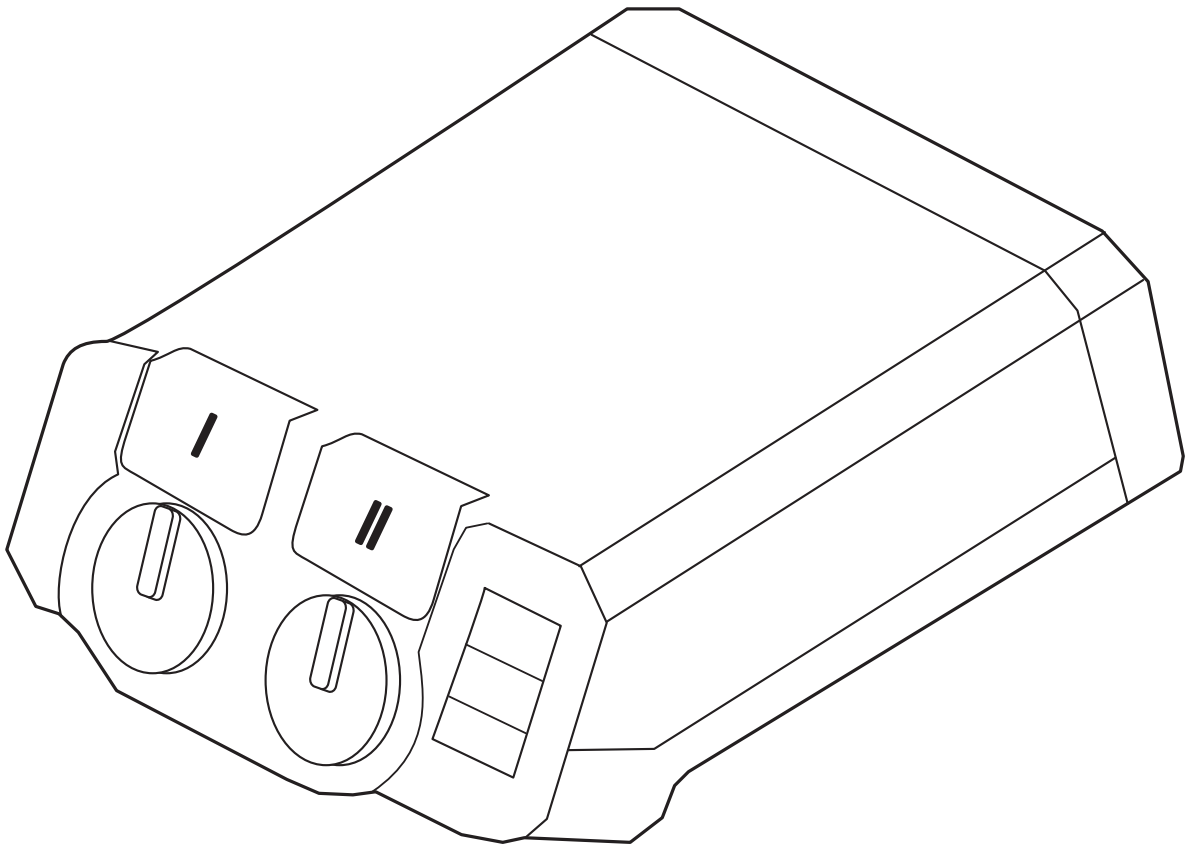

**PROPRIETARY NOTICE**

The product information and design disclosed herein were originated by and are the property of Telex Communications, Inc. Telex reserves all patent, proprietary design, manufacturing, reproduction, use and sales rights thereto, and to any article disclosed therein, except to the extent rights are expressly granted to others.

**COPYRIGHT NOTICE**

Copyright 2007 by Telex Communications, Inc. All rights reserved. Reproduction, in whole or in part, without prior written permission from Telex is prohibited.

**WARRANTY NOTICE**

See the enclosed warranty card for further details.

**CUSTOMER SUPPORT**

Technical questions should be directed to:

Customer Service Department  
RTS/Telex Communications, Inc.  
12000 Portland Avenue South  
Burnsville, MN 55337 USA  
Telephone: 800-392-3497  
Fax: 800-323-0498  
Factory Service: 800-553-5992

**RETURN SHIPPING INSTRUCTIONS**

Customer Service Department  
Telex Communications, Inc. (Lincoln, NE)  
Telephone: 402-467-5321  
Fax: 402-467-3279  
Factory Service: 800-553-5992

Please include a note in the box which supplies the company name, address, phone number, a person to contact regarding the repair, the type and quantity of equipment, a description of the problem and the serial number(s).

**SHIPPING TO THE MANUFACTURER**

All shipments of product should be made via UPS Ground, prepaid (you may request from Factory Service a different shipment method). Any shipment upgrades will be paid by the customer. The equipment should be shipped in the original packing carton. If the original carton is not available, use any suitable container that is rigid and of adequate size. If a substitute container is used, the equipment should be wrapped in paper and surrounded with at least four (4) inches of excelsior or similar shock-absorbing material. All shipments must be sent to the following address and must include the Proof of Purchase for warranty repair. Upon completion of any repair the equipment will be returned via United Parcel Service or specified shipper, collect.

Factory Service Department  
Telex Communications, Inc.  
8601 East Cornhusker Hwy.  
Lincoln, NE 68507 U.S.A.  
Attn: Service

This package should include the following:

Qty	Description	Part No.
1	Final Assy, BP325, Gray	9010673800
	Final Assy, BP325, Rev 2.0	9010673820
	Final Assy, BP325, Black	9010673821
1	User Manual	9350569000
1	Warranty Statement	38110387
1	EMC & LVD Statement	38109675

# Table Of Contents

## **Chapter 1 - Connections And Operation**

Connections .....	1
Headset .....	1
Intercom Channels .....	1
Operation .....	2
Programmable Options .....	3
Factory Settings .....	3
Jumpers (W1-w7) .....	4
Sidetone Adjustment .....	5
Alternate Powering Methods .....	5
General .....	5
Method One: One Channel Operation With A Non-rts Power Supply .....	5
Line Input Connector Wiring For 1-channel Operation With Non-rts Power Supply .....	6
Bottom View Of The Main Circuit Board .....	6
Line Loop Connector Wiring For 2-channel Operation With Non-rts Power Supply. ....	6
Line Input Connector Wiring For 2-channel Operation With Non-rts Power Supply .....	6
Method Two: Two Channel Operation With A Non-rts Power Supply .....	7

## **Chapter 2 - Replacement Parts**

Where To Obtain Parts .....	9
Electrical Parts .....	10

## **Chapter 3 - Specifications And Drawings**

Specifications .....	15
Drawings .....	16
Front Panel Board Assembly, Bp325 .....	17
Main Board, Bp325 .....	18
Rear Panel Assembly, Bp325 .....	19
Rear Panel Assembly, Bp325 .....	20
Final Assembly, Bp325 .....	21
Schematic Diagram, Front Panelcircuit Board .....	22
Schematic, Main Board Page 1 .....	23
Schematic, Main Circuit Board Page 2 .....	24
Bp-325 Cable Assemblies .....	25



# *CONNECTIONS AND OPERATION*

---

---

This section describes operation of the BP325 as supplied from the factory. Use of an RTS power supply to power the intercom system is assumed. For options and use of an alternate power source (See “PROGRAMMABLE OPTIONS” on page 3. and See “ALTERNATE POWERING METHODS” on page 5..

---

## *CONNECTIONS*

### **Headset**

Connect a headset using one of the three headset connectors on the back panel. The MONO HEADSET and STEREO HEADSET connectors are for monaural or stereo dynamic-mic headsets. The CARB-MIC HEADSET connector is for a monaural carbon-mic headset. Refer to the specifications for pin-outs of these connectors if needed.

### **Intercom Channels**

Connect the BP325 to the intercom system using the LINE INPUT connector on the back panel.

If desired, connect an additional intercom station to the intercom system using the LINE LOOP connector on the back panel.

1. Channel 1 talk button, indicator light and listen volume control.
2. Channel 2 talk button, indicator light and listen volume control.
3. Call button and indicator light.
4. Carbon-mic headset jack. May also be used for external mic switch. See "Programable Options".
5. Program volume control. Active only when using the line loop connector for optional program input. See "Programable Options".
6. Monaural dynamic-mic headset jack.
7. Intercom line loop connector for connection to additional intercom stations. May also be used for external program input, external mic switch, or a non-standard power source. See "Programable Options" and "Alternate Powering Methods".
8. Intercom line connector. For connection to intercom system.
9. Stereo dynamic-mic headset jack.
10. Rear cover removal to set options: Loosen two screws (10a) and remove one screw (10b).

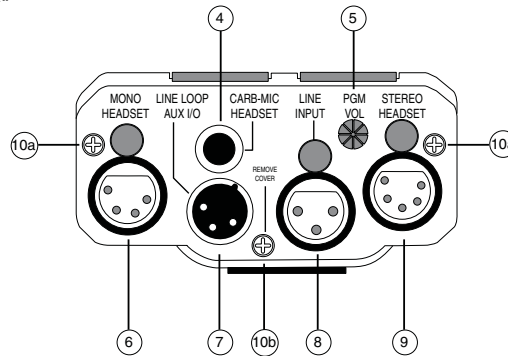
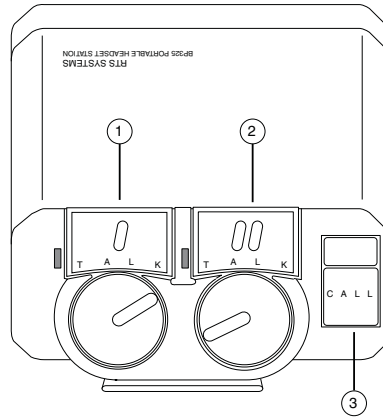

## OPERATION

1. Attach the BP325 to your belt or other convenient location using the belt clip on the rear panel.
2. Put on the headset and adjust the listen volume controls while listening to the intercom channels.
3. A TALK button may be activated in either of two ways:
  - Momentary Mode:** Press and hold the TALK button, then speak into the microphone. The green talk LED will remain lit while the TALK button is held. Release the TALK button when finished talking. The talk LED will turn off.
  - Latching Mode for Hands-free Conversation:** Tap the TALK button (do not press and hold). The green talk LED will turn on and remain on. When finished talking, tap the TALK button again. The talk LED will turn off.
4. Calling an intercom channel:
  - a. Turn on the TALK button for the channel to be called (the green talk LED should be lit).
  - b. Press and hold the CALL button. The red call LED will light while the button is pressed, indicating that a call signal is being sent. When a response is heard, release the CALL button and begin your conversation.
  - c. Turn off the TALK button when finished with your conversation.
5. Receiving a call:

- a. When there is an incoming call on a channel, the red call LED will flash.
  - b. If a talk LED is also flashing, this indicates that you need to activate that TALK button to begin your conversation.
  - c. If no talk LED is flashing, this indicates that the TALK button is already on; simply begin your conversation.
6. Sending a Talk-off Signal: The BP325 can generate an inaudible signal which can be used to deactivate the talk buttons on other intercom stations connected to an intercom channel. (May be used with models BP325, MCE325 and MRT327). This feature is useful when an unattended intercom station has its microphone activated and is causing noise on an intercom channel. To send a talk-off signal:
- a. Turn off both TALK buttons on the BP325.
  - b. Tap the CALL button three quick taps. The red call LED will turn on for about 2 seconds.
  - c. While the red call LED is on, momentarily press the TALK button for the channel that has the TALK button to be turned off. This will send the signal and turn off the remote TALK button.

**PROGRAMMABLE OPTIONS**

Several internal option switches and jumpers can modify the belt pack’s operation. The factory settings are summarized below. To change any of the factory settings, remove the rear cover screws as shown in Figure 1. Jumper and switch locations are shown on the label inside the rear cover.

**FACTORY SETTINGS**

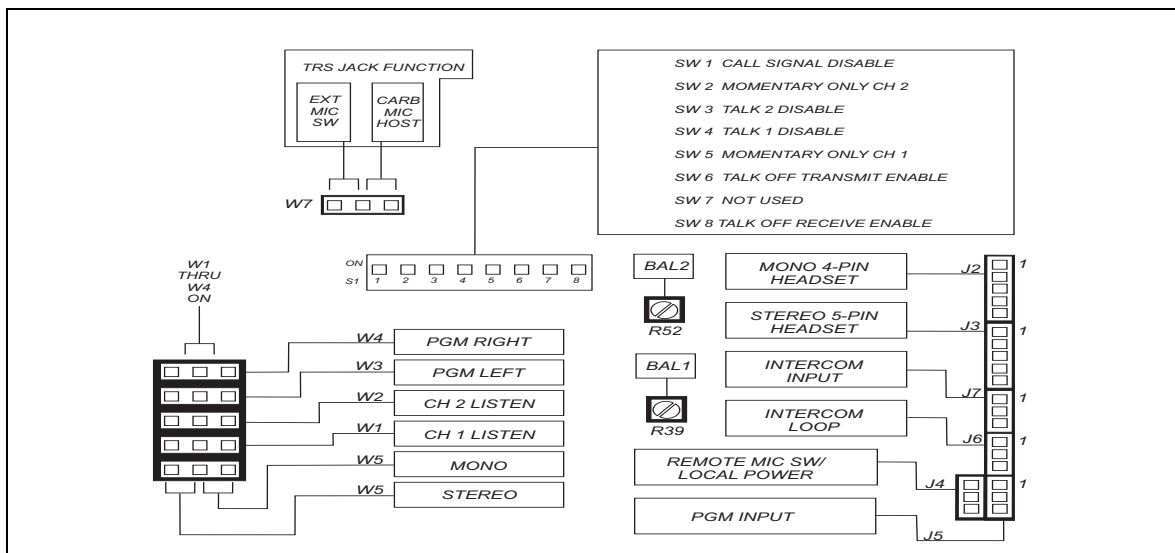

**TABLE 1.** BP-325 Unit Jumper Settings - This equipment complies with the requirements in Part 15 of the FCC Rules for a Class A computing device. Operation of this equipment in a residential area may cause unacceptable interference to radio and TV reception requiring the operator to take whatever steps are necessary to correct the interference.

**Jumpers (W1-W7)**

No. Setting	Description	Factory Default
W1	CH 1 Intercom Audio Listen <sup>a</sup>	ON
W2	CH 2 Intercom Audio Listen <sup>a</sup>	ON
W3	Program input to left headphone <sup>b</sup>	OFF
W4	Program input to right headphone <sup>b</sup>	OFF
W5	Stereo/Mono operation <sup>c</sup>	Stereo
W6	Not Used	
W7	CARB/MIC Jack Function <sup>d</sup>	Headset

**DIP Switches (S1)**

1	Call Signal Transmit Disable	OFF
2	Momentary Only Talk Button, CH2 <sup>e</sup>	OFF
3	CH2 Talk Disable <sup>f</sup>	OFF
4	CH1 Talk Disable <sup>f</sup>	OFF
5	Momentary Only Talk Button, CH1 <sup>e</sup>	OFF
6	Talk-off Transmit enable <sup>g</sup>	ON
7	Not Used	OFF
8	Talk-off Receive Enable <sup>h</sup>	ON

a. Listen is factory set to be ON all the time on both channels. Setting W1 to the OFF position will disable intercom listen audio on channel 1 (usually the left headphone of a stereo headset). Setting W2 to the OFF position will disable intercom listen audio on channel 2 (usually the right headphone of a stereo headset). Listen disable could be used, for example, when you want to use the left side of a stereo headphone exclusively for program audio input and the right side for a single channel of intercom audio. In this case you would:

1. Set W1 to OFF to disable channel 1 intercom audio listen to the left headphone.
2. Set DIP switch 4 to ON to disable channel 1 talk.
3. Setup the left channel for program input.

- b. To use program audio input:
1. Unplug the LINE LOOP connector from J6, and plug it into J5.
  2. If you are using a stereo headset, set W3 and/or W4 to ON to route the program audio to the left headphone, right headphone or both headphones. If you are using a mono headset, set both W3 and W4 to ON.
  3. Connect the program source to the LINE LOOP connector using an XLR-3-32 female receptacle wired as follows
    - Pin 1 - Common
    - Pin 2 - Program input high
    - Pin 3 - Program input low
  4. Adjust program input volume using the PGM VOL control on the back panel.

c. W5 applies to a stereo dynamic-mic headset connected to the STEREO HEADSET jack. With W5 set in the stereo position, intercom channel 1 will be heard in the left headphone only, and channel 2 will be heard only in the right. In the mono position, both intercom channels (and program audio if connected) will be heard in both headphones. If you are using monaural headphones connected to the MONO HEADSET jack, W5 may be left in the stereo position.

d. The CARB-MIC connector may be used to connect either a headset or an external mic ON/OFF switch. (If you are using a carbon-mic headset, but still wish to use an external mic switch, the LINE LOOP connector may alternatively be used for the mic switch. See note X, below.) To use the CARB-MIC connector for an external mic ON/OFF switch:

1. Place jumper W7 in the "EXT MIC SW" position.
2. Use a stereo phone plug to connect the external switch to the CARB-MIC HEADSET jack:

Tip: Remote Mic Switch Normal-open Contact

Ring: No connection

Sleeve: Remote Mic Switch Common

3. To use the external mic switch, first set one or both TALK buttons to the latched-on position. Then, press the external mic switched turn the TALK button(s) ON. Release the mic switch to turn the TALK button(s) OFF. Note, the TALK buttons may still be turned ON or OFF from the BP-325; however, the external mic switch will not work unless the TALK buttons are first turned ON at the BP-325



- e. As supplied, the TALK buttons feature a dual-action momentary/latching operation: press and hold for momentary talk, then release when finished; or tap to latch ON for hands-free talk, and tap again to turn OFF when finished talking. If desired, the latching operation may be defeated, and the TALK buttons may be operated in momentary mode only.
- f. Setting DIP switch 3 to the ON position will disable the channel 2 TALK button. Setting DIP switch 4 to the ON position will disable the channel 1 TALK button.
- g. As supplied, the BP-325 can generate an inaudible talk-off signal which can be used to deactivate the talk buttons on other intercom stations connected to an intercom channel. To turn this feature OFF, set DIP switch 6 to the OFF position.
- h. As supplied, other intercom stations can deactivate the TALK buttons on the BP-325 using the Talk-Off feature from their intercom stations. To disable this feature, set DIP switch 8 in the OFF position.
- i. Using the LINE LOOP connector for an external mic ON/OFF switch:
  - 1. Unplug the LINE LOOP connector from J6 on the circuit board, and plug it into J4.
  - 2. Connect the external mic switch to the LINE LOOP connector using an SLR-3-32 female receptacle wired as follows:

Pin 1:	Remote Mic Switch Common
Pin 2:	No Connection
Pin 3:	Remote Mic Switch Normal-open Contact
  - 3. To use the external mic switch, first set one or both TALK buttons to the latched-ON position. Then, press the external mic switch to turn ON the TALK button(s). Release the mic switch to turn off the TALK button(s). Note, the TALK buttons may still be turned ON or OFF from the BP-325; however, the external mic switch will not work unless the TALK buttons are first turned on at the BP-325.

---

## *SIDETONE ADJUSTMENT*

You can change the level of your own voice heard in your headphones while talking on an intercom channel. Adjust R39 to change your voice level when talking on channel 1. Adjust R52 to change your voice level when talking on channel 2.

---

## *ALTERNATE POWERING METHODS*

### **GENERAL**

When using an RTS power supply to power the intercom system, power is carried to the BP325 on pin 2 of the LINE INPUT connector along with the channel 1 audio. Pin 1 is the DC return. The unique design of RTS power supplies permits power to be carried on an audio channel. RTS power supplies also provide the proper terminating impedance for each intercom channel. If a non-RTS power supply is used, there are two alternatives for connecting power and intercom audio.

The first method uses channel 1 only to connect the non-RTS power supply. Audio on channel 1 will be unusable as the power supply will look like a short circuit at audio frequencies. Channel 2, however, will still be operational. Also, channel 2 will require a terminating impedance, since this is not supplied by the non-RTS power supply.

The second method allows the use of a non-RTS power supply while still maintaining two audio channels. This method requires an additional wire to the belt pack, and the LINE LOOP connector will not be usable for connecting another intercom station. Also, each intercom channel must be properly terminated. The two methods are discussed below.

### **METHOD ONE: ONE CHANNEL OPERATION WITH A NON-RTS POWER SUPPLY**

Using an XLR-3-32 female connector, connect the external power source and the channel terminating components to the LINE INPUT connector as shown in Figure 2.

If desired, the LINE LOOP connector may be used to connect power and audio to an additional intercom station.

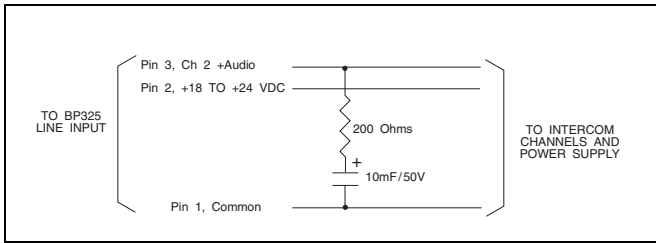

**FIGURE 1.** LINE INPUT Connector Wiring for 1-Channel Operation with Non-RTS Power Supply

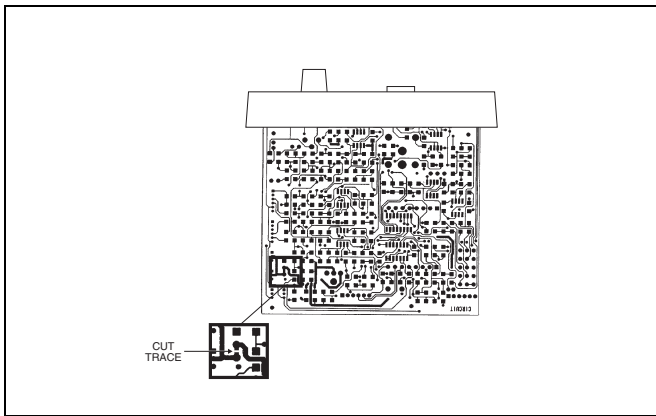

**FIGURE 2.** Bottom View of the Main Circuit Board

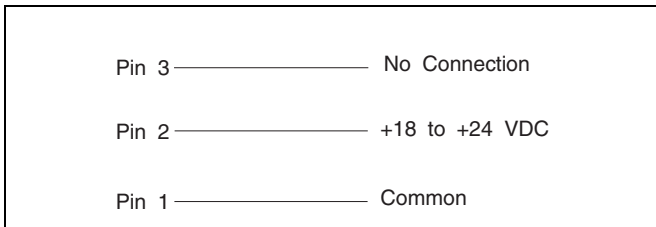

**FIGURE 3.** LINE LOOP Connector Wiring for 2-Channel Operation with Non-RTS Power Supply.

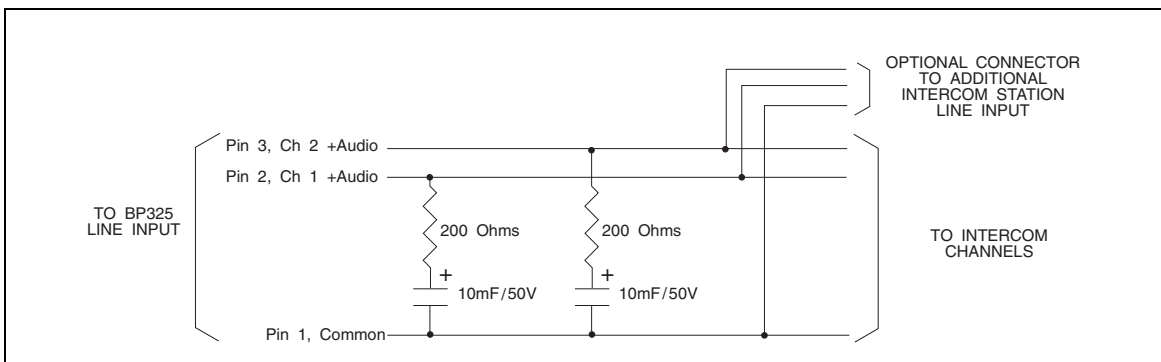

**FIGURE 4.** LINE INPUT Connector Wiring for 2-Channel Operation with Non-RTS Power Supply

## **METHOD TWO: TWO CHANNEL OPERATION WITH A NON-RTS POWER SUPPLY**

1. Referring to Figure 1, remove all three screws (10a and 10b) on the back connector panel of the BP325. Remove the rear cover/belt clip assembly.
2. There are two connectors that connect the main circuit board to the front panel circuit board. Pry the tabs on these two connectors to disconnect them. Remove the back connector panel and main circuit board from the belt pack.
3. On the bottom side of the main circuit board, cut the trace as shown in Figure 3.
4. Reassemble the main circuit board and rear connector panel to the belt pack.

**Note:** If the rear connector panel becomes separated from the main circuit board at any time, make sure that the shaft of the program volume control knob inserts into the program volume control potentiometer on the main circuit board during reassembly.

5. Referring to the label on the inside of the rear cover, unplug the LINE LOOP connector from J6 and plug it into J4.
6. Reassemble the rear cover.
7. Using an XLR-3-32 female receptacle, connect the external power source to the LINE LOOP connector as shown in Figure 4. Connect +DC to pin 2 and connect power supply common to pin 1.

Using an XLR-3-32 male plug, connect intercom channels and termination components as shown in Figure 5. Plug this connector into the LINE INPUT jack of the BP325.



# *REPLACEMENT PARTS*

---

---

## *WHERE TO OBTAIN PARTS*

Parts may be obtained directly from RTS at:

***TELEX/RTS SYSTEMS***  
Attn: Factory Service  
8601 East Cornhusker Hwy.  
Lincoln, NE 68507 U.S.A.

**REPLACEMENT PARTS**

**MECHANICAL PARTS**

<b>Final Assembly (Refer to Figure 5, "Final Assembly, BP325," on page 21 drawing for Item No. locations)</b>			
<b>Item No.</b>	<b>Qty</b>	<b>Description</b>	<b>RTS Part No.</b>
1	1	Front/Top Panel Assy, BP325	9020673700
2	1	Front/Top Panel Assy, BP325	9020673720
3	1	Back Panel Assy., BP325	9020673600
4	1	Bottom Case w/ Belt Clip, BP325	9020563500
5	3	Screw, 4-40 X 3/4" LG	1008407600
6	1	Label, Serial, GM035260	3101001700
7	1	Front/Top Panel Assy., BP325, Black	9020673721
8	1	Back Panel Assy., BP325. Black	9020673621
9	1	Bottom Case w/ belt clip, BP325, Black	9020563521

<b>Rear Panel Assy (Refer to Figure 3, "Rear Panel Assembly, BP325," on page 19 drawing for Item No. locations)</b>			
<b>Item No.</b>	<b>Qty</b>	<b>Description</b>	<b>RTS Part No.</b>
1	1	Back Panel, Gray	9080563700
2	1	Back Panel, Black	9080563701
3	3	Release Lever, Blue	9160563701
4	3	Release Lever, Dark Gray	9160563711
5	1	Knob, Program Volume	9160677500
6	1	Connector Assy, Line Input	25026736000
7	1	Connector Assy, Line Loop Aux I/O	25026736001
8	1	Connector Assy, Mono Headset	25026736002
9	1	Connector Assy, Stereo Headset	25026736003
10	1	Screw, M2.5 X 0.45 X 8MM	FST000023000

<b>Front/Top Panel Assy (Refer to Figure 1, "Front Panel Board Assembly, BP325," on page 17 drawing for Item No. locations)</b>			
<b>Item No.</b>	<b>Qty</b>	<b>Description</b>	<b>RTS Part No.</b>
1	1	Front Case, Gray	9020563601
2	1	PCB Assembly, BP325	90306634000
3	1	PC Board Assembly, BP325 6*90406635000	90306635000
4	3	Screw, #3-24 x 3/8" Pan Head	51856-035
5	1	Button Talk CH1 (FAM)	9160563603
6	1	Button Talk CH2 (FAM)	9160563604
7	1	Lens Call	9150563606
8	1	Button Call (FAM)	9160563605
9	2	Knob Boot	9160563602
10	2	Knob Body Nylon	9160563601
11			
12	2	Pushnut Fastener	1005021100
13	1	PC Board Assy, BP325 Rev 2.0	90306635001
14	1	Front Case, Black	9020563602
15	1	Button, Talk, CH1, Dark Gray	9160563613
16	1	Button, Talk, CH2, Dark Gray	9160563614
17	1	Button, Call, Dark Gray	9160563615
18		Loctite	BE753

**REPLACEMENT PARTS**

***ELECTRICAL PARTS***

ITEM	QTY	REF	PART NUMBER	VALUE					
					39	7	C4,C5,C14,C36,C37,C107,C112	102879216	1000PF
					40	10	C2,C18,C19,C20,C25,C27,C28,C33,C39,C104	102879204	100PF
1	9	C12,C22,C23,C24,C26,C30,C31,C32,C46	1099R2263GT	22UF	41	6	C15,C21,C29,C102,C103,C105	102879271	10PF
2	1	C41	1502R2284E	2200UF			C6,C7,C8,C11,C17,C44,C45,C106,C108,C109,C111,C113,C114,CC1,CC2,CC3,CC4,CC5,CC6,CC7,CC10,CC11,CC12,CC13,CC14	102880226	.1UF
3	1	U11	53266124		42	25			
4	2	U13,U14	53281100		43	1	C13	102881339	.01UF
5	1	U8	53290000		45	8	C1,C3,C110,C9,C115,C40,C42,C43	102884215	47UF
6	4	J4,J5,J6,J7	59958103		46	8	C16,C34,C35,C38,C100,C101,C116,C117	102884606	1.0UF_35V
7	1	U10	59631000		47	1	U12	90157491010	
8	2	J2,J3	59958106		48	1	U2	53266123	
9	4	Q2,Q3,Q11,Q15	102210000		49	1	R65	1412100601	50K
10	13	D1,D2,D3,D7,D8,D9,D10,D11,D12,D13,D101,D102,D103	102252000		50	2	FB1,FB2	59180303	
11	2	R4,R6	102404146	301	51	2	R39,R52	14090065SMT	10K
12	2	R62,R64	102404300	10K	53	1	D6	16010004SMT	
13	4	R42,R43,R55,R56	102404329	20K	54	2	D4,D5	16016481SMT	
14	6	R40,R41,R53,R54,R61,R63	102404375	60.4K	55	4	Q10,Q12,Q13,Q14	16025087SMT	
15	3	R69,R128,R130	1025132R7	2.7	56	1	Q1	16025484SMT	
16	3	R27,R44,R57	102513101	100	57	1	U15	16030008SMS	
17	6	R3,R8,R29,R31,R33,R49	102513102	1K	58	4	U3,U4,U6,U7	16030131SMT	
19	5	R25,R30,R66,R68,R70	102513103	10K	59	1	U5	16030140SMS	
20	17	R11,R19,R21,R23,R28,R45,R58,R59,R60,R67,R78,R79,R85,R101,R102,R103,R104	102513104	100K	60	1	U1	16030833SMT	
21	1	R71	102513112	1_1K	61	1	SS1	19090002SMS	
22	1	R24	102513153	15K	62	6		2007009900	
23	3	R18,R26,R77	102513201	200	63	2	J8,J9	20070143SM	
24	9	R12,R13,R80,RR1,RR2,RR3,RR4,RR5,RR6	102513220	22	64	4	TP1,TP2,TP3,TP4	2017001400	
25	34	R1,R2,R14,R20,R22,R34,R36,R37,R38,R46,R48,R50,R51,R73,R74,R75,R76,R82,R83,R84,R106,R108,R109,R110,R111,R124,R126,R129,R131,R132,R133,R134,R135,R136	102513223	22K	65	1	Y100	33010009SM	19.6608MHZ
27	1	R112	102513225	2.2M	66	1		4502001600	
28	6	R32,R105,R107,R113,R114,R115	102513274	270K	67	1		90406635000	
29	2	R72,R81	102513300	30	68	2	RP1,RP2	1411220200	22K
30	1	R122	102513302	3K	69	1	J1	2013004900	
31	5	R119,R120,R121,R125,R127	102513473	47K	70				
32	3	R116,R117,R118	102513474	470K	71	1	W8	102513000	
33	3	R15,R16,R17	102513515	5.1M	73	6	W1,W2,W3,W4,W5,W7	2515001500	
34	2	R9,R10	102513621	620	74	1		1006004100	
35	2	R35,R47	102513683	68K	75	1		1007000700	
36	1	R123	102513390	39	76	1		1008402300	
38	1	C10	102879212	470PF	77	1		2703002900	
					78	AR		51741000	
					79	2	R5,R7	102404246	3.01K





# Specifications and Drawings

## Specifications

### Dimensions

5.00" High x 3.75" Wide x 2.05" Deep  
(127mm x 96.3mm x 52.1mm)

### Weight

0.5 pounds (225 grams)

### Exterior

Polystyrene and polycarbonate mix; gray textured main body

### Power Requirements

#### Input DC Voltage

=18 to +35 volts DC, operating; -200 to +36 volts DC  
without damage

#### DC Current

mA  
Average talk + call light: 6 No Signal: 27 milliamperes.  
Average talk (25 ohm headphones, 10dB below clipping): 43  
0mA

### Impedance Across Intercom Line

10,000 ohms typical

### Ambient Temperature Range

Operating: 0°C to 50°C (32°F - 122°F)

Storage: -40°C to 125°C (-40°F to 257°F)

### Noise Contribution to 200-Ohm Intercom Line

-75 dBu

### Headphone Amplifier

Maximum Voltage Gain: 30dB

Frequency Response: 100 Hz to 8 kHz,  
+/-3 dB

Headphone Impedance: 50 to 600 ohms

Output Power: 150 mW/50 ohms

Output Voltage Level: 8 volt peak-to-peak

### Microphone Preamplifier

Maximum Voltage Gain: 54 dB

Frequency Response: 100 Hz to 8 kHz,  
+/-3 dB

Input Impedance: 1,000 ohms, balanced

Limiter Range: 30 dB

### Program Input

Maximum Input Level: +20 dBu

Nominal Input Level: -10 to +8 dBu

Frequency Response: 100 Hz to 12 kHz,  
+/-3 dB

### Monaural Dynamic-mic Headset Connector

XLR-4-31 receptacle (J13)

Pin 1 - Microphone low

Pin 2 - Microphone high

Pin 3 - Common

Pin 4 - Headphone high

### Stereo Dynamic-mic Headset Connector

XLR-5-31 receptacle (J14)

Pin 1 - Microphone low

Pin 2 - Microphone high

Pin 3 - Common

Pin 4 - Headphone left high

Pin 5 - Headphone right high

### Carbon-mic Headset Connector (J1) - 1/4 inch, 3-conductor Phone Jack

#### Used for Headset

Tip - Carbon microphone

Ring - Headphone

*Drawings*

<b>Drawing Number</b>	<b>Title</b>
9030-6634-000	Front Panel Circuit Board Assembly
9030-6635-000	Main Board Layout
9020-6736-000	Rear Panel Assembly
9020-6737-000	Front/Top Panel Assembly
9010-6738-000	Final Assembly
9027-6635-000	Schematic Diagram, Main Circuit Board (pages 1 & 2)
2502-6736-000	Cable Assemblies

Figure 1: Front Panel Board Assembly, BP325

CAM350 V 9.1.1 : Wed Dec 13 08:48:28 2006 - 6634-000\_e1.cam

NOTES:

1. MANUFACTURING TO MARK REV ON BOARD THAT APPEARS ON DRAWING
2. REFERENCE SCHEMATIC DRAWING 9027-6634-000 REV A
5. THIS ASSEMBLY IS TO BE CONSTRUCTED USING ROHS COMPLIANT COMPONENTS, SOLDERS AND PROCESSES PER TELEX SPC000017002.

				SHEET	SHEET REVISION STATUS
				REV.	

REVISIONS							
LOC.	REV.	DESCRIPTION	ECO. NO.	DRFT	CHKR	APP	DATE
	C	REVISED AND REDRAWN IN POWER PCB	73821	SX	CBH		6-17-02
	D	ADD: ITEM #8; SWITCH EXTENDER	73963	SX			10-10-02
	E	MODIFY BOM AND ASY PRINT FOR ROHS COMPLIANCE	46-000663	SX	SX		12-13-06

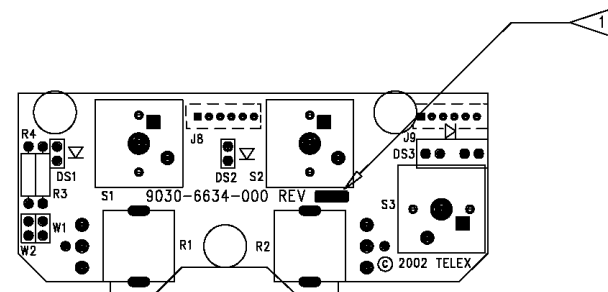

				3	8	XS1, XS2, XS3	701635-000	SWITCH EXTENDER
				.001	7	AR	SS360	CAIG DEOXIT SPRAY 3DSS-6
				2	6	DS1, DS2	1801575100	LED, PY5351K
				1	5	DS3	1801002000	LED, MU16-2105 STANLEY
				3	4	S1, S2, S3	545094-001	KEYSWITCH WITH FIXATION PINS, MX SERIES, MX1A-11NW
				2	3	J8, J9	2007014400	CONNECTOR, JST#06R-F-J
				2	2	R1, R2	1406003901	POT, 10K OHM AUDIO, NOBLES #V012LPV-20F-15A10K
				1	1		9040-6634-000	BP325 FRONT PANEL PCB
-004	-003	-002	-001	-000	ITEM	REF	PART NUMBER	DESCRIPTION
QTY.	QTY.	QTY.	QTY.	QTY.	NO.	DESIG.		
					REV		LIST OF MATERIALS	

<p><b>CAD GENERATED DRAWING</b></p> <p>FILE NAME: IC_GROUP/ECAD/BOARDS/6634/REVE/6634E1.PCB</p>	<p>MODEL</p> <p>NEXT ASS'Y</p>	<p>UNSPECIFIED LIMITS OF TOLERANCE</p> <p>STRAIGHTNESS AND/OR FLATNESS .005 IN./1 IN.</p> <p>CONCENTRICITY .010 TIR</p> <p>ANGLES P1/2D BENDS P2D</p> <p>UNMARKED ANGLES, BENDS AND INTERSECTIONS 90D</p> <p>THREADS- EXT. CLASS 2A INT. CLASS 2B</p> <p>MOLD FINISH: SPI-SPE NO. 3 DRAFT 2D</p>	<p>DR SX</p> <p>DATE 6-04-02</p>	<p>CK CBH</p> <p>SCALE NONE</p>	<p>APP</p> <p>DO NOT SCALE DRAWING</p>	<p>TITLE</p> <p><b>BP325</b></p> <p><b>FRONT PANEL BOARD ASSEMBLY DRAWING</b></p>
			<p>MINNEAPOLIS, MINNESOTA</p>	<p>P/N</p> <p>SIZE <b>B</b></p> <p>DWG. NO. <b>9030-6634-000</b></p> <p>SHEET 1 OF 1</p>	<p>PLANT DIST. BE, LNC</p>	

Figure 2: Main Board, BP325

NOTES:

1. MANUFACTURING TO STAMP REV ON BOARD THAT APPEARS ON DRAWING
2. REFERENCE SCHEMATIC DRAWING 90276635-000 REV H
3. PARTS LIST FILED SEPARATELY 90306635-000 REV L
4. PARTS LIST FILED SEPARATELY 90306635-001 REV L
5. THIS ASSEMBLY IS TO BE CONSTRUCTED USING ROHS COMPLIANT COMPONENTS, SOLDERS AND PROCESSES PER TELEX SPC000017002.
6. U12 IS 9015749010 FOR 90306635000  
U12 IS 9015749020 FOR 90306635001
7. W4 AND W5 ARE ON FOR THE "ABC" VERSION.
8. DEFAULT POSITIONS FOR SWITCH SS1 ARE 6,8 - ON & 1-5, 7 OFF

SHEET		SHEET REVISION STATUS
NO.	REV.	

REVISIONS							
LOC.	REV.	DESCRIPTION	ECO. NO.	DATE	DRFT	CHKR	APP
	D	REVISED & REDRAWN	62113	CBH			11/25/97
	E	CHANGED NOTES 2 & 3	63577	CBH			11/9/98
	F	ADD BALLOON 78	63920	JV			1/12/00
	G	CHANGED NOTE 3; ADDED NOTE 4	73472	SX	CBH		6/19/01
	H	CHANGED NOTES 3 & 4	73673	SX			1/7/02
	J	CHANGED NOTES 3 & 4	44-000182	MMB			1/27/06
	K	CHANGED NOTES 3 & 4	44-000204	MMB			09/15/06
	L	MODIFY BOM AND ASY PRINT FOR ROHS COMPLIANCE	46-000663	SX	SX		12/13/06
	M	ADD NOTES 6, 7 ,8.	44-000600	SMc	SMc		08/08/07

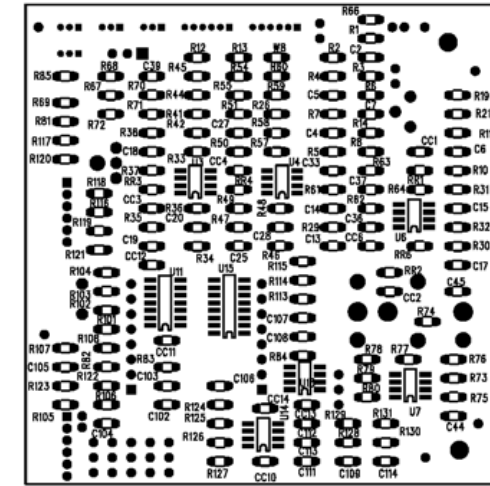
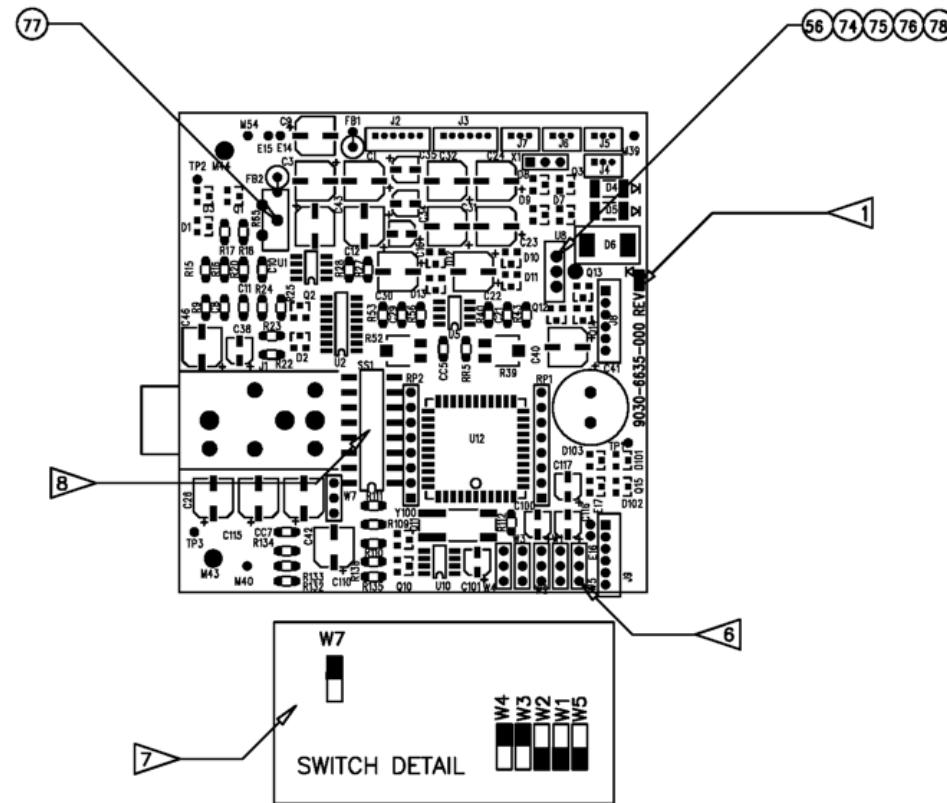

CAD GENERATED DRAWING  
FILE NAME: IC\_GROUP/ECAD/BOARDS/6635/REVE/6635E15.PCB

DR	CBH	CK	APP	TITLE	MODEL BP 325
DATE	1-25-97	SCALE	1:1	MAIN BOARD	
DO NOT SCALE DRAWING				P/N	
				SIZE	B
				DWG. NO.	90306635
MINNEAPOLIS, MINNESOTA				SHT.	1 OF 1
				PLANT DIST.	LNC, CTI

Figure 3: Rear Panel Assembly, BP325

Date: 4/18/2007

Time : 10:48:16 AM

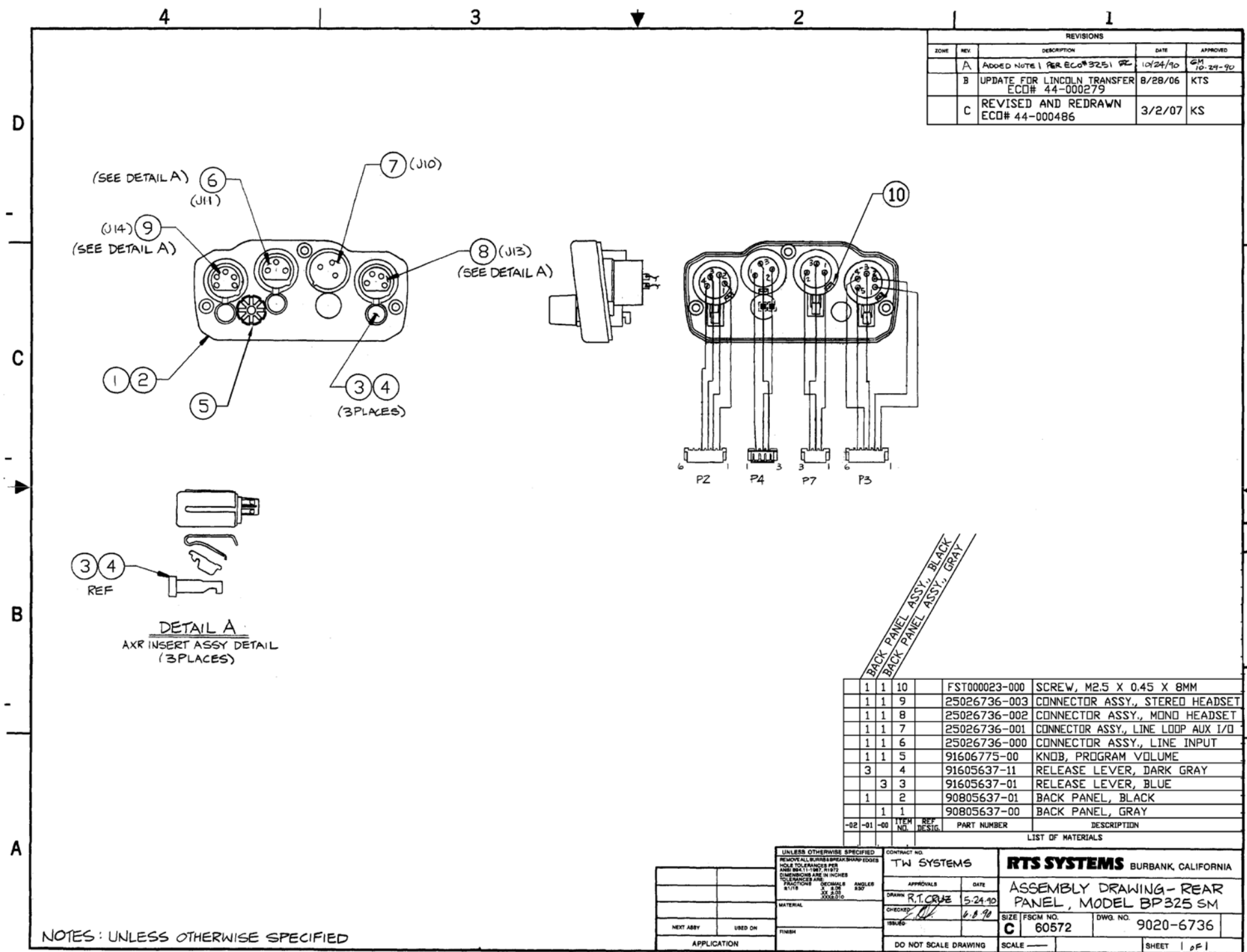

Title: D:\psp\_custom\_telem\genview\work\958729\90206736\_01.CAL

Figure 4: Front/Top Panel Assembly, BP325

Date: 4/18/2007

Time : 10:47:53 AM

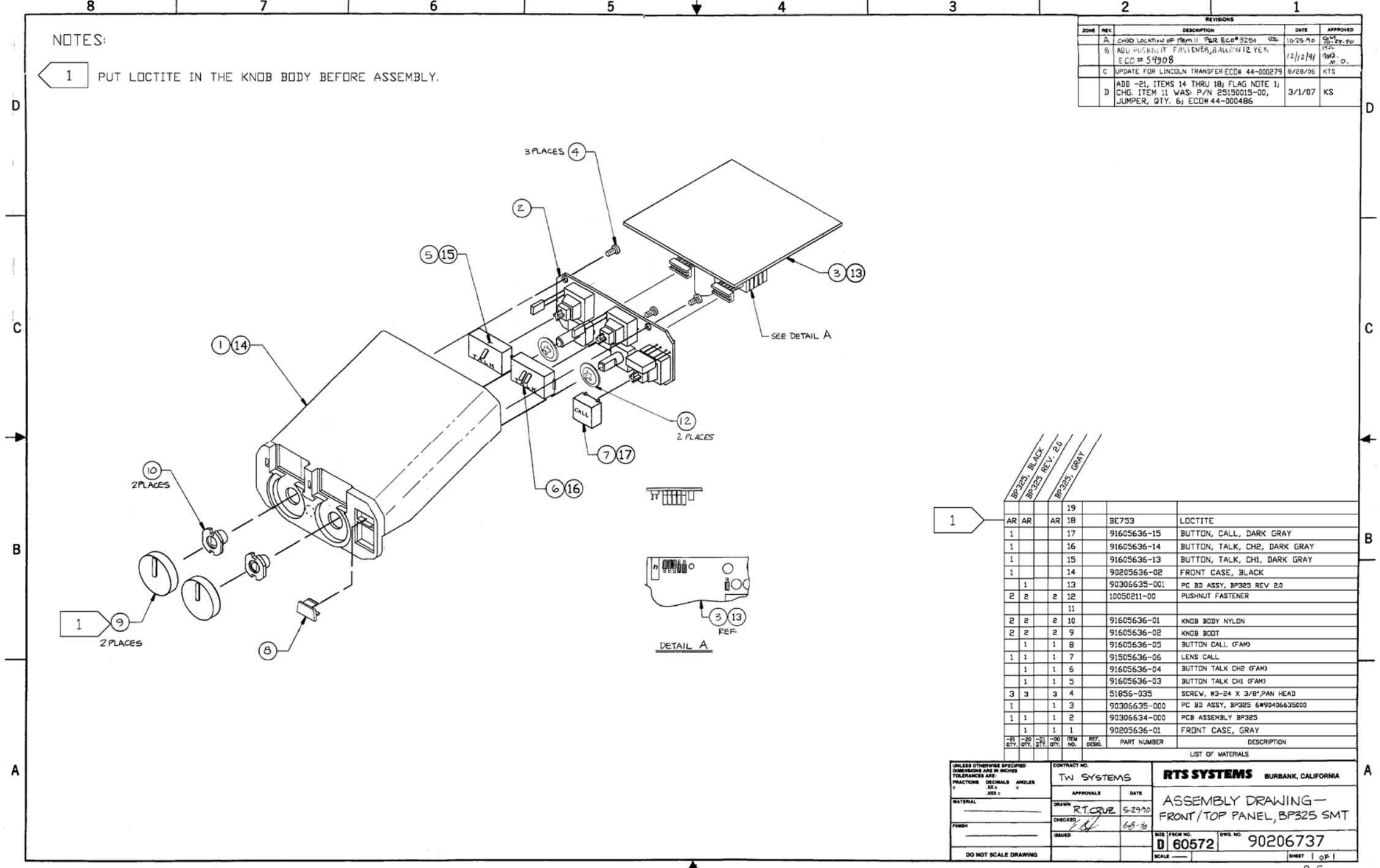

ZONE	REV.	DESCRIPTION	DATE	APPROVED
A		CHGD LOCATION OF ITEM 11 PER ECO# 3251	10/25/00	COM. REV. 00
B		ADD PUSHNUT FASTENER, BALUN W/ 12 YEK. ECO# 54908	12/12/01	M.O.
C		UPDATE FOR LINCOLN TRANSFER ECO# 44-000279	8/28/06	KTS
D		ADD -21, ITEMS 14 THRU 18; FLAG NOTE 1; CHG. ITEM 11 WAS: P/N 25150015-00, JUMPER, QTY. 6; ECO# 44-000486	3/1/07	KS

QTY.	QTY.	QTY.	QTY.	REF. DESIG.	PART NUMBER	DESCRIPTION
1	AR	AR	AR	19	BE753	LOCTITE
1				17	91605636-15	BUTTON, CALL, DARK GRAY
1				16	91605636-14	BUTTON, TALK, CH2, DARK GRAY
1				15	91605636-13	BUTTON, TALK, CH1, DARK GRAY
1				14	90205636-02	FRONT CASE, BLACK
1				13	90305635-001	PC BD ASSY, BP325 REV 2.0
2	2	2	2	12	10050211-00	PUSHNUT FASTENER
				11		
2	2	2	2	10	91605636-01	KNOB BODY NYLON
2	2	2	2	9	91605636-02	KNOB BOOT
1	1	1	1	8	91605636-05	BUTTON CALL (FAM)
1	1	1	1	7	91505636-06	LENS CALL
1	1	1	1	6	91605636-04	BUTTON TALK CH2 (FAM)
1	1	1	1	5	91605636-03	BUTTON TALK CH1 (FAM)
3	3	3	3	4	51856-035	SCREW, #3-24 X 3/8", PAN HEAD
1	1	1	1	3	90305635-000	PC BD ASSY, BP325 6W90406635000
1	1	1	1	2	90305634-000	PCB ASSEMBLY BP325
1	1	1	1	1	90205636-01	FRONT CASE, GRAY

UNLESS OTHERWISE SPECIFIED DIMENSIONS ARE IN INCHES TOLERANCES ARE: FRACTIONS DECIMALS ANGLES

CONTRACT NO. TW SYSTEMS

APPROVALS: DATE: 5-29-00

DRAWN: RT. CRUZ

CHECKED: [Signature]

ISSUED: 6-8-00

RTS SYSTEMS BURLINGAME, CALIFORNIA

ASSEMBLY DRAWING - FRONT/TOP PANEL, BP325 SMT

SIZE: FROM NO. D 60572 DWG. NO. 90206737

SCALE: SHEET 1 OF 1

8.E.

Title: D:\psp\_custom\_telem\genview\work\958728\90206737\_01.CAL

Figure 5: Final Assembly, BP325

Date: 4/18/2007

Time : 10:51:15 AM

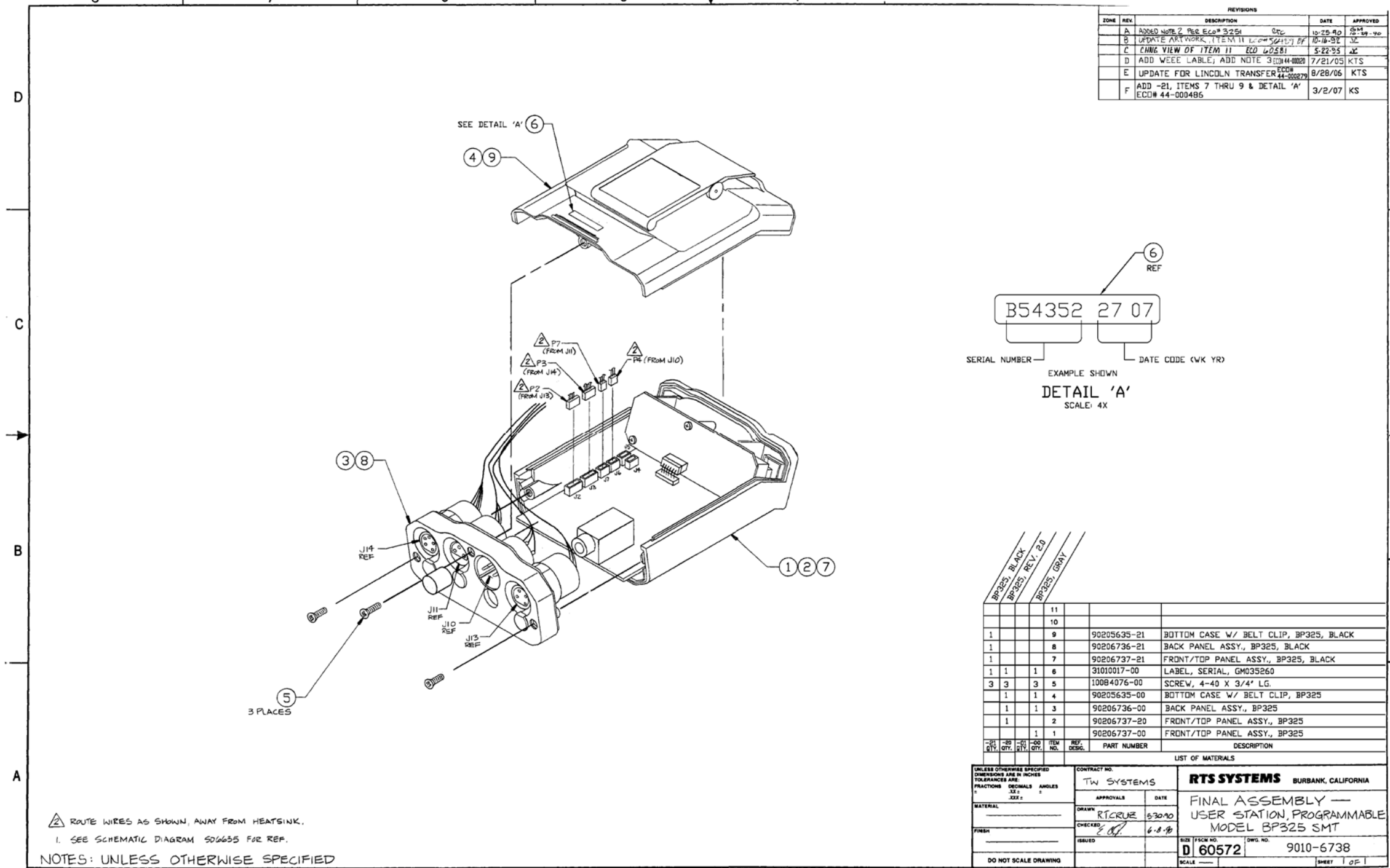

ZONE	REV	DESCRIPTION	DATE	APPROVED
	A	ADDED NOTE 2 PER ECO# 3251	10-25-90	CS
	B	UPDATE ARTWORK, ITEM 11 L.O.# 524157 OF	10-16-92	JC
	C	CHANGE VIEW OF ITEM 11 ECO 40581	5-22-95	JC
	D	ADD WEEE LABEL; ADD NOTE 3 (ECHO# 4000)	7/21/05	KTS
	E	UPDATE FOR LINCOLN TRANSFER (ECHO# 44-000279)	8/28/06	KTS
	F	ADD -21, ITEMS 7 THRU 9 & DETAIL 'A' ECO# 44-000486	3/2/07	KS

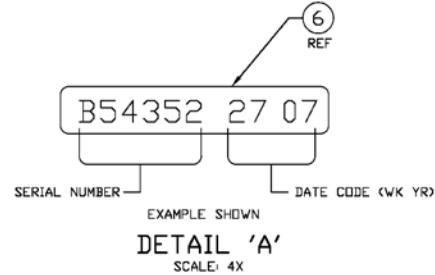

BP325, BLACK		BP325, REV. 20		BP325, GRAY	
	11				
	10				
1	9	90205635-21	11	BOTTOM CASE W/ BELT CLIP, BP325, BLACK	
1	8	90206736-21	10	BACK PANEL ASSY., BP325, BLACK	
1	7	90206737-21	9	FRONT/TOP PANEL ASSY., BP325, BLACK	
1	6	31010017-00	8	LABEL, SERIAL, GM035260	
3	5	10084076-00	7	SCREW, 4-40 X 3/4" LG.	
1	4	90205635-00	6	BOTTOM CASE W/ BELT CLIP, BP325	
1	3	90206736-00	5	BACK PANEL ASSY., BP325	
1	2	90206737-20	4	FRONT/TOP PANEL ASSY., BP325	
1	1	90206737-00	3	FRONT/TOP PANEL ASSY., BP325	
1	1	90206737-00	2	FRONT/TOP PANEL ASSY., BP325	

UNLESS OTHERWISE SPECIFIED DIMENSIONS ARE IN INCHES TOLERANCES ARE FRACTIONS DECIMALS ANGLES		CONTRACT NO.		RTS SYSTEMS BURBANK, CALIFORNIA	
XX .XXX X		TW SYSTEMS		FINAL ASSEMBLY —	
MATERIAL		APPROVALS		USER STATION, PROGRAMMABLE	
DRAWN		DATE		MODEL BP325 SMT	
CHECKED		6-8-90		SIZE (FICH NO.) DWG. NO.	
SERVED		6-8-90		D 60572 9010-6738	
DO NOT SCALE DRAWING				SHEET 1 OF 1	

△ ROUTE WIRES AS SHOWN, AWAY FROM HEATSINK.  
 1. SEE SCHEMATIC DIAGRAM SD6635 FOR REF.  
 NOTES: UNLESS OTHERWISE SPECIFIED

Title: D:\psp\_custom\_telem\genview\work\958737\90106738\_01.CAL

Figure 6: Schematic, Main Board page 1

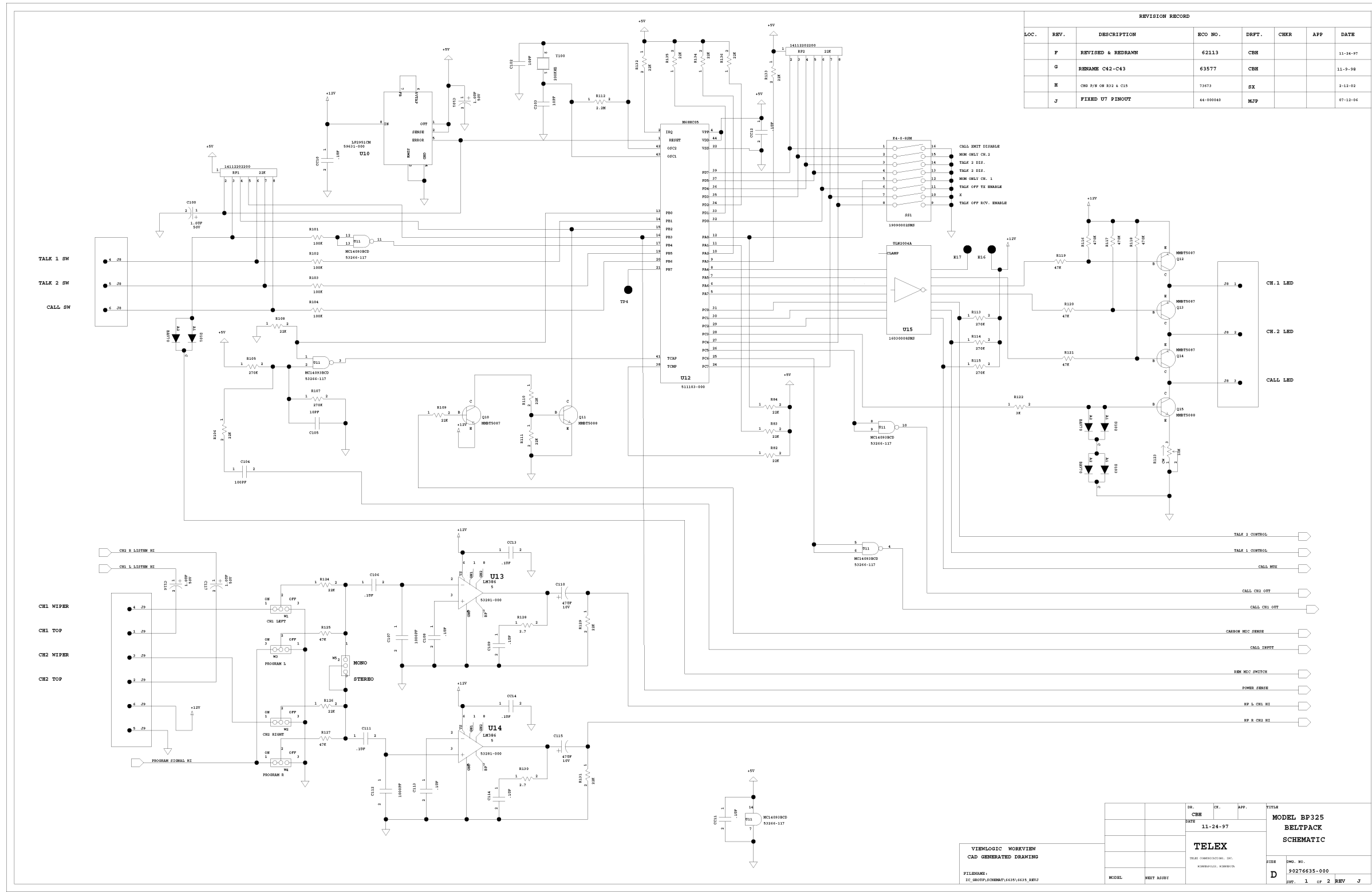



Figure 7: Schematic, Main Circuit Board page 2

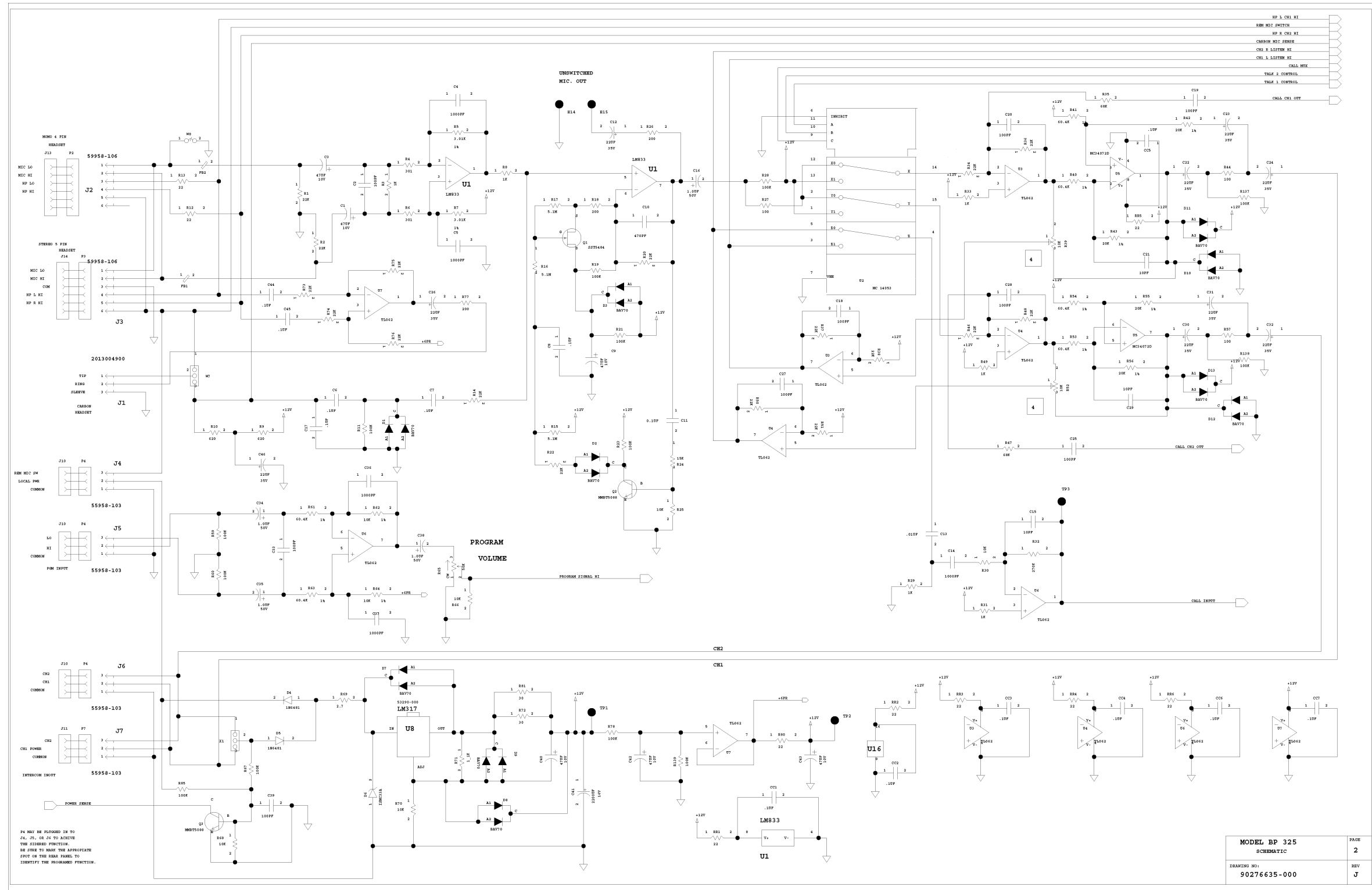
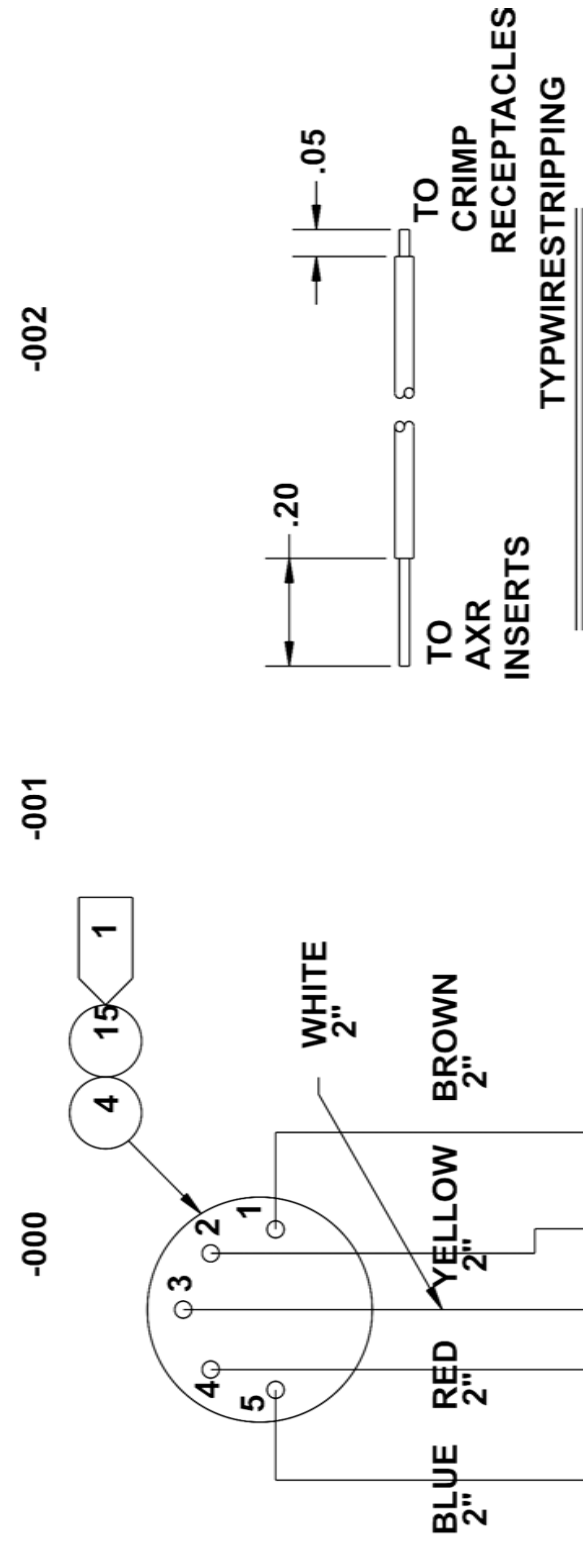
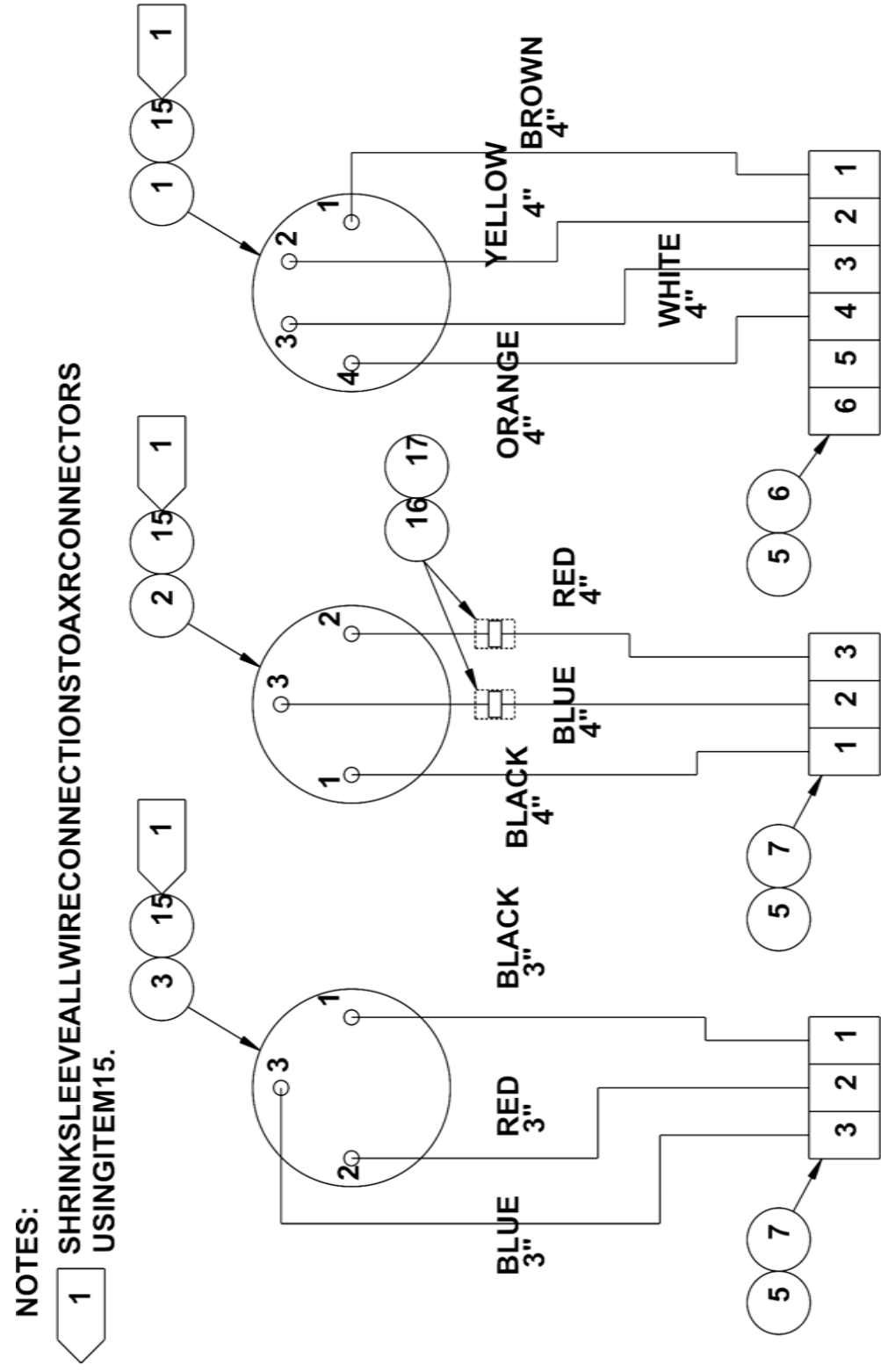

Figure 8: BP-325 Cable Assemblies



-002

-001

-000

-003



