

## INPUT PANEL

**1. 1/4" INPUT & THRU** - input connection for instruments and thru-put for on-stage amplifier.

**2. 3.5mm TRS** - input connection for stereo -10dB consumer audio electronics.

**3. RCA INPUT** - left and right input connection for stereo -10dB consumer audio electronics.

**4. RCA THRU** - left and right parallel thru-put of signals connected to the 1/4", 3.5mm TRS and RCA inputs.

**5. -15dB PAD** - reduces the input level by 15dB to prevent overload from high output devices.

**6. XLR INPUT** - this recessed switch selects between the hi-Z and the XLR inputs.

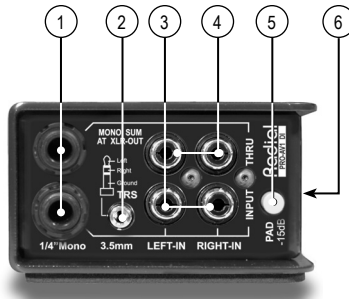

## OUTPUT PANEL

**7. XLR LINE INPUT** - this XLR input is specifically designed to accept +4dB line-level signals from balanced sources.

**8. GROUND LIFT** - disconnects pin-1 on the XLR output connector to help reduce noise caused by ground loops.

**9. XLR OUTPUT** - balanced, 600 ohm, mic-level output is 100% transformer-isolated and compatible with mic splitters and console preamps.

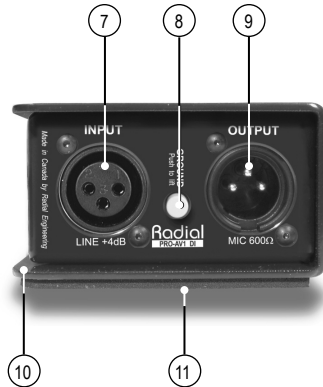

## CONSTRUCTION

**10. BOOK-END DESIGN** - 14 gauge steel outer shell provides a protective zone for the switches and connectors.

**11. FULL BOTTOM PAD** - neoprene foam foot provides electrical isolation and plenty of friction to stay put on hectic stages.

**12. WELDED I-BEAM CASE** - inner steel enclosure is made extremely rigid with I-beam profile. Eliminates stress that could torque the PC board and cause solder joint failure.

**13. MILITARY-GRADE** - double-sided PCB is bolted to steel standoffs for toughness.

**14. RADIAL TRANSFORMER** - linear freq. response from 20Hz to 18kHz for natural sound. Mu-metal shield to eliminate electromagnetic interference.

**15. ISOLATED CONNECTORS** - are made from extremely tough glass-filled nylon for true electrical isolation from chassis ground.

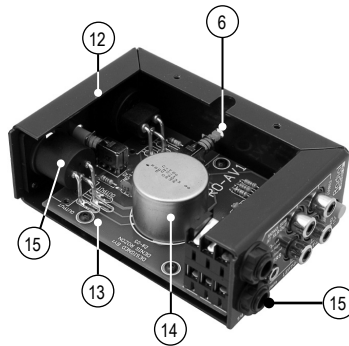

## ProAV1 SPECIFICATIONS

Frequency response	20Hz to 18kHz +/- .5dB
Total harmonic distortion	0.01% THD 20Hz to 20kHz
Input	Unbalanced high-Z -10dB RCA, 1/4" and 3.5mm TRS
	Balanced low-Z +4dB XLR
Output	Balanced 600-Ohm, mic-level, pin-2 hot
Input pad	-15dB
Power requirement	None, completely passive
Size	3.25" x 5" x 1.875"
Weight	1.6 lbs

## RADIAL LIMITED THREE YEAR TRANSFERABLE WARRANTY

Radial Engineering - a division of JP Cabletek Electronics Ltd. - warrants this product to be free from defects in material and workmanship and will remedy any such defects free of charge according to the terms of this warranty. Radial Engineering will repair or replace at its option any defective component(s) of this product, excluding the finish, the bottom foam pad and wear and tear from normal use, for a period of three (3) years from the original date of purchase. In the event that a particular product is no longer available, Radial Engineering reserves the right to replace the product with a similar product of equal or greater value. To make a request or claim under this limited warranty, the product must be returned prepaid in the original shipping container (or equivalent) to Radial Engineering or to an authorized repair centre and you must assume the risk of loss or damage. A copy of the original invoice showing date of purchase and the dealer name must accompany any request for work to be performed under this limited warranty. This limited warranty shall not apply if the product has been damaged due to abuse, misuse, misapplication, accident or as a result of service or modification by any other than an authorized repair centre.

THERE ARE NO EXPRESSED WARRANTIES OTHER THAN THOSE ON THE FACE HEREOF AND DESCRIBED ABOVE. NO WARRANTIES, WHETHER EXPRESSED OR IMPLIED, INCLUDING BUT NOT LIMITED TO, ANY IMPLIED WARRANTIES OF MERCHANTABILITY OR FITNESS FOR A PARTICULAR PURPOSE, SHALL EXTEND BEYOND THE RESPECTIVE WARRANTY PERIOD DESCRIBED ABOVE OF THREE YEARS. RADIAL ENGINEERING SHALL NOT BE RESPONSIBLE OR LIABLE FOR ANY SPECIAL, INCIDENTAL OR CONSEQUENTIAL DAMAGES OR LOSS ARISING FROM THE USE OF THIS PRODUCT. THIS WARRANTY GIVES YOU SPECIFIC LEGAL RIGHTS, AND YOU MAY ALSO HAVE OTHER RIGHTS, WHICH MAY VARY DEPENDING ON WHERE YOU LIVE.

## ProAV1 Direct Box Users Guide



Radial Engineering  
1638 Kebet Way, Port Coquitlam BC V3C 5W9  
Tel: 604-942-1001 Fax: 604-942-1010  
email: info@radialeng.com

Radial Engineering is a division of C-TEC (JP CableTek Electronics Ltd.)  
Radial ProAV1 users guide V1.0 - Part #: R870 1140 00  
Subject to change without notice

www.radialeng.com

## CONGRATULATIONS

on your purchase of the Radial ProAV1 passive direct box. This innovative DI features a 'Swiss army knife' compliment of connectivity options making the PROAV1 the perfect DI for professional AV integrators and rental companies that regularly deal with a variety of system interface problems. As with all Radial products the ProAV1 is easy to use. This short manual contains all the information you need to start using the ProAV1 right away. For more information on the ProAV1 and other Radial products, visit our website at [www.radialeng.com](http://www.radialeng.com).

The Radial ProAV1 is a clever and useful device that will provide you with years of problem-solving connectivity. It may even save the show ten minutes before curtain. Enjoy!

## INTRODUCTION

The ProAV1 is a single channel DI with stereo inputs and a merge function that mixes left and right signals to a mono, mic-level, 600 Ohm XLR output. Upon inspection, you will notice the Radial ProAV1 is equipped with multiple input connector formats that allow virtually any audio device to be connected. In addition to standard 1/4" instrument inputs, the ProAV1 is equipped with 3.5mm and RCA jacks for -10dB consumer audio devices like MP3 and CD players. An XLR jack allows +4dB line-level pro-audio equipment to be properly connected to a microphone snake and console preamp.

At the heart of the ProAV1 is the Radial transformer that balances the signal and provides level and impedance conversion while isolating noise caused by ground loops. Radial transformers, manufactured for optimum signal transfer and minimal insertion loss, are exceptional for their linear frequency response and ability to handle high input levels without distortion. The transformer is mounted in a mu-metal can for protection against electromagnetic fields produced by power transformers, lighting dimmers and video displays.

The ProAV1 is completely passive and therefore does not require any power whatsoever to make it work. With its heavy-duty steel construction the ProAV1 is well suited for touring and rental use.

## CONNECTING THE ProAV1

Before connecting the ProAV1 make sure the sound system is turned off and all levels are set to zero. This will avoid any pops in the sound system that could cause damage to speakers. Also confirm that the PAD, LIFT and XLR INPUT SELECT buttons are in their "out" positions. Phantom power will not damage the ProAV1.

## ProAV1 BLOCK DIAGRAM

Follow the block diagram from the inputs on the left to the output on the right. A really cool feature shown in the diagram is the hi-Z input jacks are paralleled together in stereo. This makes any unused hi-Z jack a handy patch point to pass the signal on to mixers or amplifiers. Next, the stereo inputs are merged to mono through a resistive network designed to minimize phase cancellation.

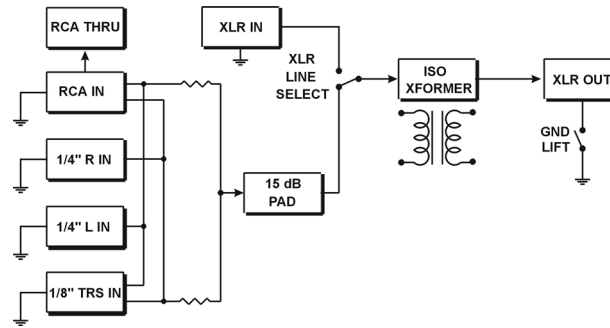

## RCA & 3.5mm JACKS - CONSUMER -10dB AUDIO EQUIPMENT

Consumer audio electronics like CD players, computer sound cards and MP3 players may connect directly to the ProAV1 without cumbersome adaptors through the 3.5mm and RCA inputs.

## 1/4" JACKS - INSTRUMENTS

Musical instruments may be connected to the 1/4" input jacks. When connecting a mono instrument, like a bass guitar, the instrument connects to the 1/4" INPUT jack and the player's on-stage amplifier is connected to the 1/4" THRU jack.

When connecting stereo instruments, like synthesizers, the two 1/4" jacks may be used for left and right channels. The signal may be accessed at the RCA THRU or 3.5mm jacks and passed to mixers, sound cards or on-stage amplifiers.

## XLR BALANCED +4dB INPUT

Pro-audio equipment with a balanced +4dB line output may be connected to the ProAV1 XLR input. The XLR input is activated by a recessed switch on the side of the ProAV1. Push the recessed switch in to activate the XLR input and disable the 1/4", 3.5mm and RCA inputs. The ProAV1 will convert the +4dB line input to a mic-level signal at the XLR output.

## -15dB PAD

The ProAV1 is equipped with a -15dB input PAD to prevent overload distortion when interfacing high output devices like CD players. The PAD reduces the input to the transformer and will not effect the level at the thru-put jacks. The XLR input is preset for +4dB signals and is not affected by the PAD.

## TRANSFORMER ISOLATION

The ProAV1 transformer converts hi-Z inputs to a low impedance, balanced, mic-level signal. A huge benefit of using transformers for signal conversion is the isolation the transformer provides by preventing the flow of ground currents between the input and output. This isolation effectively blocks hum and buzz caused by ground loops.

## GROUND LIFT

To make grounding as flexible as possible the ProAV1 features a ground LIFT switch. When the LIFT switch is in the "in" position, pin-1 on the XLR output is disconnected, interrupting the ground between the source device and mixing console. This can help to reduce noise caused by ground loops.

## XLR OUTPUT

The ProAV1 produces a balanced, 600 Ohm, mic-level signal that is compatible with microphone snakes systems and mixing consoles preamps. Balanced signals can drive very long cables without appreciable noise or signal loss.

## ACCESSORIES

### OPTIONAL J-RAK

The optional J-RAK is a 2RU rack chassis that allows up to 8 Radial devices in one neat 19" package. The DIs can be mounted with either the input side or output side facing the front.



### OPTIONAL J-CLAMP

The optional J-CLAMP can mount a single Radial device to virtually any surface. Perfect for hiding away inside racks, on podiums or under tables.

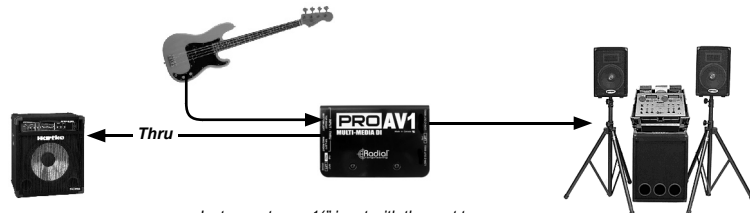

Instrument uses 1/4" input with thru-put to amp. Mic-level output to PA system.

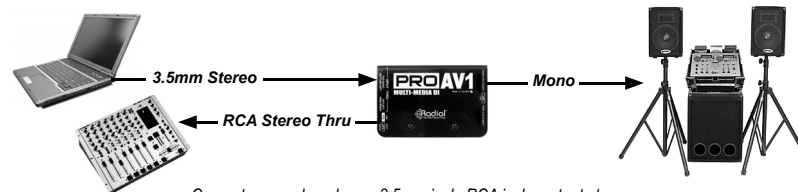

Computer sound card uses 3.5mm jack. RCA jacks output stereo signal to local mixer. Mono mic-level output to PA system.

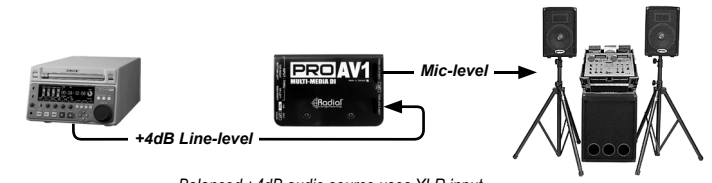

Balanced +4dB audio source uses XLR input.