

Radio Systems, Inc.

CT-2002 Clock/Timer Manual

For Models:

CT-DESK

CT-THIN

CT-2INCH

CT-4INCH

CT-CONSOLE

CT-DESKGPS

CT-2INCHGPS

CT-SYNC Clock to PC Synchronization Kit

GPS-SYNC GPS to PC Synchronization Kit



Table of Contents

General Description	
Models	4
Options	4
General Operating Instructions	
Clock/Timer (Mode) Select	5
To Set the Clock.....	5
To Use the Up Timer.....	5
To Utilize as Slave Clock Display.....	6
To Utilize as Slave Timer Display.....	7
Time-of-Day Offset.....	8
Infrared Remote Control	
Up Timing.....	9
Down Timing.....	9
Storing Down Times.....	9
Recalling Stored Down Times	10
On Power Up.....	10
Time-of-Day Set	10
Setting to Slave Display.....	10
Setup Functions.....	11
Infrared Remote Control Diagram.....	13
GPS Driver	
Additional Operating Instructions.....	14
Setup Programming	14
Top-of-Hour Closure	14
Connections and Installation	14
Operation.....	15
GPS Error Codes.....	15
GPS Antenna RJ-45 Connector Wiring	15
PC Synchronization and GPS Antenna Cable Extension	
GPS-SYNC Synchronization Kit.....	16
CT-SYNC Synchronization Kit	16
CT-150CABLE -150ft. Extension Cable	17
CT-250CABLE -250ft. Active Extension Cable	17
Wiring and Programming Diagrams	
Master Synchronization via "Lead Clock," ToH, or PC Using Twisted Pair	18
Master Synchronization via "Lead Clock," ToH, or PC Using RJ-45 Patch Wire	19
Master Synchronization via GPS Using Twisted Pair	20
Master Synchronization via GPS Using RJ-45 Patch Wire.....	21
Remote Control Connections.....	22
CT-2002 GPS Antenna Wiring Options	23
CT-2002 GPS DIP Switch Settings Diagram.....	24
Policies	
Warranty	25
Repair Policy.....	25
Return Instructions	25

General Description

The CT-2002 series of digital clock/timers is a family of timing displays, a master driver and a GPS driver.

Models

All Display Models:

Will accept serial Time-of-Day and timer data in Radio Systems format, or Time-of-Day (only) data in SMPTE format. Provides up-timing as standard and down-timing with the optional IR remote control. Each display model (with V2005 or higher software) will output serial data for Time-of-Day in Radio Systems format.

CT-DESK

7" wide x 2.5" high x 4.5" deep Desktop clock/up-down timer with 5/8" LED displays which functions as a stand alone or slave time of day display with wired remote control.

CT-THIN

7" wide x 2.5" high x 1.25" deep "stick-on" clock/timer with 5/8" LED displays featuring the same functions as the desktop unit, but in a smaller profile cabinet.

CT-2INCH

15.25" wide x 5.25" high x 3" deep clock/timer display with 2" high LED display and the same features set as the "desktop" and "thin" units.

CT-4INCH

24.5" wide x 7" high x 3" deep clock/timer display with 4" high LED display and the same features set as the "desktop" and "thin" units.

GPS Models:

Provide up-timing and output serial Time-of-Day data in Radio Systems format.

Options

Infra-Red Remote Control

Required for down timing and internal setup functions. Also provides clock operation, Time-of-Day Set and up-timer functions (for display units only.) Included with Desktop & Large Display.

RS-485 Converter

Installs in-line between the GPS satellite antenna and clock/receiver. Required for cable runs in excess of 150'.

General Operating Instructions

For all non GPS or master units (applies to units utilized in stand-alone and slave display capacities.)

Time-of-Day Set Up and Up-Timer functions can be controlled by the front panel buttons or the wired remote control. However, the IR Remote Control must be used for entering down times and internal setup functions.

Front Panel or Wired Remote Operation

Clock/Timer (Mode) Select

All CT-2002 units operate as both clocks and timers. Switch between modes by pressing the MODE button on the front of the unit. The front panel LED's will light to indicate the mode selected.

Note that on the CT-2002 large wall display models, the mode switch is available on the remote control only. The fourth front panel switch is used to put the clock into the set mode.

To Set the Clock:

Note: If Serial Time of Day is supplied to the CT-2002 (slave mode), it will not be possible to enter the Time-of-Day set mode. Setting the time-of-day can either be done at the master unit or the displayed hours can be offset via the IR Remote Control.

1. Press the mode button to select the Time-of-Day display. The Clock LED will illuminate.
2. (Desktop and Thin models) - press and hold the STOP and START buttons. The Set LED will illuminate.
(Large models) - press the SET button. The Set LED will illuminate.
3. Display resets to 12:00:00
4. Press the STOP button to advance the hours. Press the RESET button to advance the minutes (note - seconds are not settable and remain at :00).
5. Start the clock at the top of the minute by pressing the START button. The Set LED will extinguish.

To Use the Up Timer:

(To utilize as a Down-Timer consult IR Remote Control Instructions page 8)

1. Press the Mode Button to select the timer display. The Timer LED will illuminate.
2. Press the START button to start timing.
3. Press the STOP button to stop timing.
4. Press the RESET button to return the display to 00:00.

Slaved Displays

To Utilize as a Slaved Clock Display (CT-2002 Display units only):

1. Consult page 10 for setup functions to select either RS or SMPTE sync format.
2. Provide serial data to the unit. Choices of serial data are SMPTE time code and Radio Systems Time-of-Day data from CT-2002 GPS. In addition a CT-2002 display unit can be used to provide Time-of-Day and Timer data in the Radio Systems format. To connect to slave Time-of-Day displays only, wire only the serial data input terminals in parallel (use either the terminal strip or RJ-45 connectors—see the connections diagram on page 20 & 22).
3. The “SYNC” front panel LED will light and the time-of-day will immediately synchronize to the master unit readout.
4. Time-of-Day setting is now no longer available on this slave display. Time-of-Day setting must be made to the unit providing the serial Time-of-Day data.
5. If the data link is lost, the clock will revert to stand-alone local operation and the sync LED will extinguish.
6. Local timer functions continue to be available as described on the preceding page.
7. The minutes and seconds may be offset from the top of hour input closure. See manual section “Time-of-Day Offset on page 8 and “IR Remote control” section.
8. The hour, minutes and seconds may be offset from the upstream time-of-day serial data via the infra-red remote control. See manual section “Time-of-Day Offset on page 8 and “IR Remote control” section.

Note: software/hardware kit is available (Radio Systems part # CT-SYNC) to update Windows PC clocks from your CT-2002 serial data stream

To Utilize as a Slaved Timer Display as well as a slaved clock display. (CT-2002 Display units only):

1. Consult page 11 for Setup function programming, and choose selection 3 option "RS2" for slave timer operation.
2. Provide serial data from any CT-2002 display unit whose timer display you want to slave. Connect the serial data **output** terminals of the up-stream CT-2002 display to the serial data **input** terminals of the slave display. Use either terminal strip or RJ-45 connectivity (consult wiring diagram on page 20 & 21.)
3. Place the slave display in the clock mode and confirm that the "SYNC" front panel LED on the slave display is lit and that the slave displays shows the Time-of-Day from the up-stream unit.
4. In the "Clock" mode, the time-of-day on the slave display will now synchronize to the up-stream stand alone display (regardless of what mode is being displayed on the stand-alone upstream display.)
5. Place the slave display in the timer mode and press the "MEM 6" button on the IR remote control. Confirm that the SYNC LED on the slave lights and that the slave display shows the timer data from the up-stream display unit.
6. To return the slave display to none-slaving timer (stand-alone) functionality, press the "RESET" button on the IR remote control with the slave display in the timer mode. The "SYNC" LED will extinguish and the timer display will reset to 00:00, allowing local (IR and parallel) timer control.
7. To return to slave timer operation, push the "MEM 6" button on the IR remote control with the slave display in the timer mode. The "SYNC" LED will (re)illuminate and the display will synchronize to the up-stream stand-alone timer display.
8. Additional timers "downstream" from this slave timer may be wired to slave to this timers display, or function as Time-of-Day displays and independent stand-alone timer displays. Consult the wiring diagram on page 20 (RJ-45 patch cord wiring) or 21 (twisted pair wiring) for specific wiring configurations.

Wired Remote Control

All front panel controls are available on the rear barrier strip connector.

Contacts are momentary / pull-to-ground.

See attached wiring diagram for connections - page 18.

Time of Day Display Offset

The time of day displayed on CT2002 displays slaved from upstream GPS or Master clocks or triggered by top-of-hour input closures can be offset by any amount of seconds, minutes, or hours. Typical applications of such an offset:

- Network Top-of-hour pulses sent early (seconds before the actual top-of-hour)
- Stations running in full obsentity delay
- HD station transmission delay
- Time zone multi clock displays

To offset closure reset:

Use the infrared remote control option 10 position to enter the minutes and or seconds desired to be displayed when the top of hour closure is received.

- Note that hours displayed will not be affected.
- Note that top-of-hour is only active prior to and after the hour (to avoid false triggers at other times).
- See manual page 12 for programming instructions.

To offset serial time input from and upstream GPS or Master clock in the serial chain (RS serial time code or SMTPE time code allowed):

Use the infra red remote control to input hours to be added to time of day serial data (option 4), or minutes and or seconds to be added to the time of day serial data (option 11).

- Note that offsets are always **added** to the stream. For example:
 - To offset plus 1 hour, 10 seconds - set option 4 for 01 and option 11 for 00:10
 - To offset minus 8 seconds - set option 4 for 23 and option 11 for 00:52

Infra Red Remote Control

(Not Available on GPS MASTERS)

Up Timing

1. Press the Timer Button to place the CT-2002 into the Timer Mode. The Timer LED will illuminate.
(If the "Down" LED is illuminated, press the Reset Button. It may require two presses.)
2. Press the Start Button to start up timing.
3. Press the Stop Button to stop up timing.
4. Press the Start Button to resume up timing.
5. Press the Reset Button to clear the display.

Down Timing

1. Press the Timer Button. The Timer LED will illuminate.
2. Using the numeric keypad, enter a down time. The Set LED and Down LED will illuminate. Hours can be from 00 to 99, minutes from 00 to 59 and seconds from 00 to 59. Erroneous entries can be overwritten or the Reset Button can be used to zero the display. An invalid time such as 12:60:00 will be cleared when the Start Button is pressed.
3. Press the Start Button to begin down timing. (The down timer can be set to either stop at zero or continue to count negative. See IR Remote Setup Functions - see page 10.)
4. Press the Stop Button to stop down timing.
5. Press the Start Button to resume down timing.
6. Press the Reset Button once to recall the entered down time. Repeat steps 3 through 6 as desired.
7. Press the Reset Button two times to exit the down mode (and to clear the display and return to up timing mode).

Storing Down Times

The IR Remote Control can be used to store up to six down times. These times are saved when power is removed from the CT-2002.

1. Press the Timer Button. The Timer LED will illuminate.
2. Using the numeric keypad, enter a down time. The Set LED and Down LED will illuminate. Hours may be from 00 to 99, minutes from 00 to 59, and seconds from 00 to 59. Erroneous entries can be overwritten or the Reset button can be used to zero the display.
3. Press one of the Store Buttons. If the time entered was valid, the display will momentarily flash, the Set LED will extinguish and the down time will be stored. In addition, the entered down time will remain on the display and the Down LED will remain illuminated. However, an invalid time (such as 12:60:00) will be cleared when a Store Button is pressed. In addition, the CT-2002 will return to the Up Timer Mode.
4. Repeat steps 2 and 3 as desired.

Recalling Stored Down Times

Previously stored down times in locations MEM1 thru MEM6 may be recalled either with the IR remote control or via the wired remote control. See connection diagram page 18.

1. Press the Timer Button. The Timer LED will illuminate.
2. Press one of the Store Buttons.
3. The stored down time will appear on the display. The Down LED will illuminate.
4. Press the Start Button to begin down timing.
5. Press the Stop Button to stop down timing.
6. Press the Start Button to resume down timing.
7. Press the Reset Button once to recall the selected down time. Repeat steps 3 through 6 as desired.
8. Press the Reset Button two times to exit the down mode (return to up timing mode) and clear the display.

On Power up

1. Units always power up into the time-of-day mode.
2. If serial data (RS or SMPTE) is supplied (and the correct mode was pre-selected with the IR Remote Control), then the serially supplied time will display.
3. The clock must be set when using the internal clock base.

Time-of-Day set

The CT-2002 will not enter the Time-of-Day set mode if serial time of day is being supplied by a master clock or GPS system. However, the displayed time may be offset up to 23 hours, (see IR Remote Setup Functions - page 13).

1. Press the Clock Mode Button to put the CT-2002 into the Clock Mode. The Clock LED will illuminate.
2. Press the Time-of-Day set button. The Set LED will illuminate.
3. Using the numeric keypad on the IR Remote Control enter the correct time. The display will advance to the next digit only if a valid time has been entered. In the event of an erroneous entry, press the Time-of-Day set button to start over.
4. Press start at the correct moment.

Setting the Timer to Act as a Slave Display

Timers can be wired to slave the display of an upstream timer. Consult wiring diagram on pages 20 & 21 for details.

1. When in timer mode, press the MEM 6 button on the IR remote control. The "SYNC" LED will illuminate and the timer will display the upstream time (the slave display must be receiving timer data from an up-stream timer, and RS2 must be selected in IR setup option three.)
2. Press the Reset Button "when in timer mode" to force the timer to operate as a local up/down timer. The "SYNC" LED will extinguish and the timer display will reset to 00:00. Operate the timer as usual.
3. Press the "MEM 6" button on the IR Remote Control to revert to slave timer readout.

Setup Functions

The IR Remote Control is used to set various functions of the CT-2002. With the exception of "IR Remote Disable" these selections are stored if power is lost.

1. Press the Program Button. The "PGM" LED will illuminate. Repeatedly pressing the Setup Button will step the CT-2002 through the 10 menu choices.
2. The selections are changed either by pressing the "CLOCK SET" button or using the numeric keypad.
3. The Setup Mode is exited (and the selections are stored) by pressing either the Clock Button or the Timer Button.
4. For a confidence check that your programming changes have been made and stored, cycle thru the setup functions without making any more changes to check that your entries are saved. Then press clock or timer to exist.

- Option 1: **12/24 hour clock operation.** Press the "CLOCK SET" button to toggle between 12 and 24 hour operation.
- Option 2: **Down timer stop at zero or count negative.** Press the Time-of-Day set button to toggle between hold at 0 or go negative.
- Option 3: **Serial time of day format.** Press the "CLOCK SET" button to toggle between Radio Systems-1 (rS1) format, Radio Systems-2 (rS2) format and SMPTE (SP) format .
- " SMPTE " enable the serial input to read standard SMPTE format (no drop frame).
- " rS1 " enables the serial inputs to read Radio Systems serial time of day format as generated by Radio Systems' GPS, Master, and stand-alone clocks.
- " rS2 " enables the serial inputs to read Radio Systems serial time of day format as well as upstream timer displays. Note that in this mode, the " Mem 6 " and RESET keys on the IR Remote control is retasked to allow switching between slave and local timer functions.
- Option 4: **Serial time of day hour offset.** Press the "CLOCK SET" button to select from 00 to 23 hour added to the serial time of day data. Use option 11 to input minutes and seconds added.
- Option 5: **IR Remote Functionality.** Press the "CLOCK SET" button to toggle between full functionality (iron), program defeat (irPr), and no remote (irno).
- In program defeat (irPr) the setup functions are locked out. When AC power is toggled off and on, the remote returns to full functionality.
- In no remote (irno) all remote functions are ignored. When AC power is toggled off and on, the remote returns to full functionality. Use this function if there is more than one clock in use in the same room.

- Option 6: **Time compare 1.** Use the numeric keypad to enter the minutes and seconds of the time compare. Time between 00:00 and 59:59 must be entered. Note that all four digits (including leading zeros) must be entered. When the minutes and seconds of the time of day are equal to the time compare stored, the matching open collector wired remote will activate.
- Option 7: **Time compare 2.** See "option 6" above.
- Option 8: **Time compare 3.** See "option 6" above.
- Option 9: **Time compare 4.** See "option 6" above.
- Option 10: **Top of Hour Reset Offset.** A wired remote input is available for top of hour reset. The default operation is to reset the time-of-day to 00 min's. & 00 sec's.
- Use the numeric keypad to reset to a different time, (minutes and seconds). When the displayed time of day is within a ± 5 minute window of the stored top of hour time and the wired remote input is activated, the displayed time will be replaced by the stored top of hour time. (This function active for stand-alone time-of-day operation only.)
- Option 11: **Serial time of day minutes and seconds offset.** Use the numeric keypad to enter the minutes and seconds desired to be added to the serial time of day data. Use option 4 to input hours to be added.

CT-2002 InfraRed Remote Control

When Up-Timing:

Push once to reset timing to 00:00
(Continues to run if reset from Stop)
(Holds if reset from Stop)

When Down-Timing:

Push once to redisplay down time.
Push again to return display to 00:00
and Up-Time mode.

In Clock Mode:

Starts display running from
Time-of-Day set mode

In Timer Mode:

Starts display running from
Up or Down Timer display

Push to freeze
Timer Display

Push to display
Time-of-Day

Push to set Time-of-Day

Enter via numeric keypad.
Push start.

Storing Down Times

1. Press the Timer Button.
The Timer LED will illuminate.
2. Using the numeric keypad, enter a down time. The Set LED and Down LED will illuminate. Hours may be from 00 to 99, minutes from 00 to 59, and seconds from 00 to 59. Erroneous entries can be overwritten or the Reset button can be used to zero the display.
3. Press one of the Store Buttons. If the time entered was valid, the display will momentarily flash, the Set LED will extinguish and the down time will be stored. In addition, the entered down time will remain on the display and the Down LED will remain illuminated. However, an invalid time (such as 12:60:00) will be cleared when a Store Button is pressed. In addition, the CT-2002 will return to the Up Timer Mode.
4. Repeat steps 2 and 3 as desired.

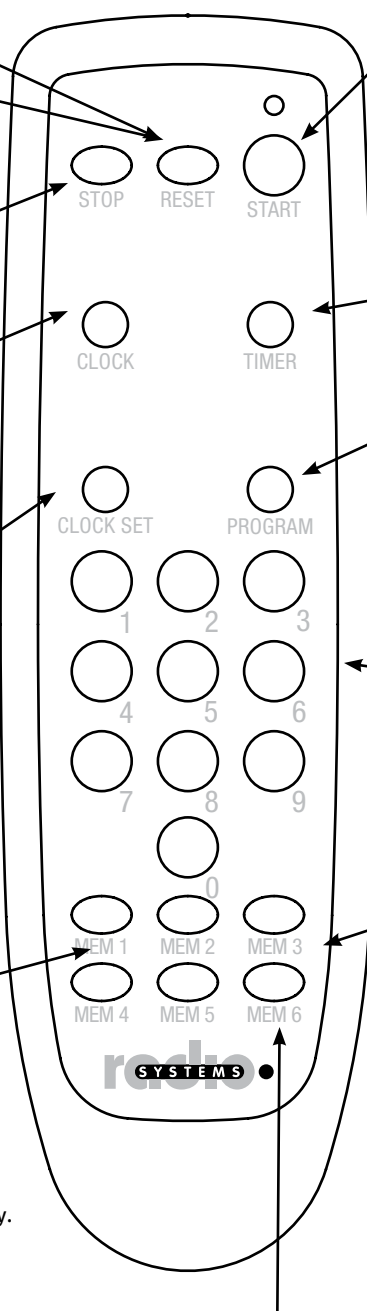

Push for Timer Mode

Push to set Internal Programming features (see setup functions on page 10).

Program functions via
numeric keypad.
Push Timer or Clock to exit
in that mode

To set down time

Enter time via numeric keypad.
Push start to begin.
Push reset to recall downtime.
Push reset 2x to exit.

Recalling Stored Down Times

1. Press the Timer Button.
The Timer LED will illuminate.
2. Press one of the Store Buttons.
3. The stored down time will appear on the display. The Down LED will illuminate.
4. Press the Start Button to begin down timing.
5. Press the Stop Button to stop down timing.
6. Press the Start Button to resume down timing.
7. Press the Reset Button once to recall the selected down time. Repeat steps 3 through 6 as desired.
8. Press the Reset Button two times to exit the down mode (return to up timing mode) and clear the display

Note: Stored Down-Time 1 can be recalled remotely via parallel remote control wiring. See illustration page 18.

MEM 6 is retasked to switch the timer between slave and local modes when using associated display as a remote timer. See page 7.

GPS Driver

Additional Operating Instructions

Setup Programming

Refer to the dip-switch setting diagram on page 23 to program the hour offset from GMT for your time zone, to enable the automatic daylight savings time setting, and to enable 12 or 24 hour operation.

Note that the unit is shipped with the factory default setting of Eastern Time Zone (5 hours behind GMT), auto daylight savings time switch-over and 12-hour operation.

The analog clock dip-switch (switch #1) causes the display to flash after recovery from a satellite signal loss as an operator indication that your analog clocks have lost time and must be reset. (Digital clocks connected to the GPS Master driver will automatically update.) After adjusting the time on the analog clock (see analog clock operation), push the start button to cease flashing and resume normal display. Factory default for this feature is "off".

Top-of-Hour Closure

GPS Master driver units (on 2" and desktop) provide a top-of-hour closure available as a C-form relay closure for 250 ms, occurring at the top of each hour. The C-form contacts are available on the rear remote control barrier strip connector on pins 15 and 16 (last two terminals on the strip). See Remote Connection diagram page 19 of this manual for connections.

Connections and Installation

1. Mount the antenna on a roof or window ledge with a clear view of the sky. Avoid areas directly under microwave antenna paths, or near dense foliage.
2. The antenna plugs into the clock/receiver via a pre-installed RJ-45 Ethernet style connector. Up to 150' of four conductor shielded cable may be installed between the antenna and the receiver. This cable may be user provided, or a pre-assembled 150' or 250' extension cable is available from Radio Systems. Please note that for any cable run in excess of 150', in-line balancing RS-485 convertor amplifiers, available from Radio Systems, must be installed. For wiring specifications, see the attached antenna wiring detail on page 23.

Operation

1. After all connections are made, apply power. The unit will take from 1 to 15 minutes to acquire the satellite data. During this initial acquisition period, and during any subsequent periods of satellite data loss, the GPS Master unit will display one of 5 error codes. These codes and their meanings are listed below.
2. After acquisition, the true time will display and will be serially relayed to any digital display units "downstream". If data is lost at any time in the future, downstream display "data" lamps will extinguish, but these clocks will continue to run on their internal time base. On satellite reacquisition, the time will be updated, and the "data" lamps re-illuminated.
3. Front panel master GPS controls cannot be used to set or change the digitally displayed time-of-day, but the time mode may be used to adjust the time on any analog clocks connected, and the START, STOP and RESET switches may be used in the timer mode. See the "Analog Clock Connection and Use" section for operating details.

GPS Error Codes

These two digit error codes will display in the GPS Master readout in the center two digits on unit turn-on (pre-satellite acquisition) and during any data outage.

Error Code	1-Pulse Per Second	Serial Data	Data
01 (1 PPS line broken)	not present	present	okay
02 (satellite acquisition lost)	present	present	bad
03 (fire-up status - first 1 to 15 minutes)	not present	present	bad
04 (corrupted serial data output)	present	not present	bad
05 (no antenna connection)	not present	not present	bad

GPS Antenna RJ-45 Connector Wiring Diagram

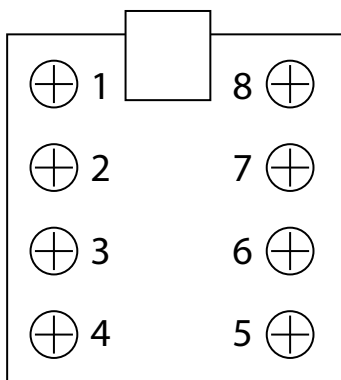

GPS Cable Color	RJ-45 Pin #	Function
BLK		
WHT/ORN		
ORN/WHT & SHIELD	1	Ground and Switch Leads*
RED	2	+15VDC
VIOLET	4	1 Pulse Per Second
WHITE	5	RxA(+)
GRAY	6	TxA(+)
WHITE/RED	8	TxB(-)

*Note: All four wires should be connected at this terminal.
(RJ-45 Pins 3 & 7 are not used)

PC Synchronization

GPS-SYNC Synchronization Kit



This hardware and software kit allows time code received directly from the GPS antenna to be read into a PC COMM (RS232 serial) port.

The kit includes an antenna, antenna outdoor mount, 12ft. connectorized serial cable, power supply and interface box, and software. A 150ft. extension cable is available as well as an RS-485 extender for extended cable runs up to 500ft.

Included software installs in any Windows XP/Vista/2000 or higher OS (Windows 8 currently not supported) and automatically updates the Windows time base with GPS accurate time. Hours, minutes and seconds offset can be set manually via software configuration screens.

CT-SYNC Synchronization Kit



This hardware and software kit allows a PC's time base to be updated via RS serial time code, **OR** allows a PC's time base to output RS serial time code. Connection to the PC is via USB and connection to CT-2002 is a two wire twisted pair serial cable. The kit includes a USB to RS485 converter and software.

One included software program installs in any Windows XP/Vista/2000 or higher OS (Windows 8 currently not supported) and automatically updates the Windows time base with CT-2002 serial time. The second software program also included installs in any Windows XP/Vista/2000 or higher OS (Windows 8 currently not supported) and automatically updates the CT-2002 clock system from the PC time base. Software is also included to allow the Garmin GPS Antenna to be directly synchronize to a PC timebase (order part# CT-GPSSYNC.)

Hours, minutes and seconds offset can be set manually via the software configuration screens or in the CT-2002 software.

PC Clock Input Sync

This software/hardware kit (Radio Systems part # CT-SYNC) is available to update Windows PC clocks via USB from the CT-2002 serial data stream OR convert the Windows time base to RS time code to drive and synchronize the CT-2002 system.

GPS Antenna Cable Extension



CT-150CABLE - 150ft. Extension Cable

150ft. of shielded CAT-5 cable with "biscuit" style RJ-45 termination boxes at each end. GPS antenna plugs into far side and near is connected to GPS clock via an RJ-45 patch cable (provided.)

Note: This cable may be shortened by the customer, but 150ft. is the maximum distance that the antenna cable may be extended without the use of the active RS-485 converter boxes (below.)



CT-RS485 - Active Antenna Extender

Active RS-232 to RS-485 extender 'biscuits'. GPS antenna plugs into far side and near is connected to GPS clock via an RJ-45 patch cable (provided.) Converter biscuits are active and powered via the GPS clock power supply. Required for use with more than 150 ft. of CAT-5 cable between antenna and GPS clock or in high RFI environments.

Note: The antenna side RS-232 converter is not in a water-proof box and must be housed indoors or in a protective closure.



CT-250KIT - 250 ft. CAT-5 Cable + Active Antenna Extender

Kit contains 250 ft. of shielded CAT-5 cable and active RS-232 to RS-485 extender 'biscuits' shown above. Cable length can be shortened to required custom length.

Master Synchronization via "Lead Clock," Top-of-hour or PC Sync. using twisted pair (CAT-5) wiring

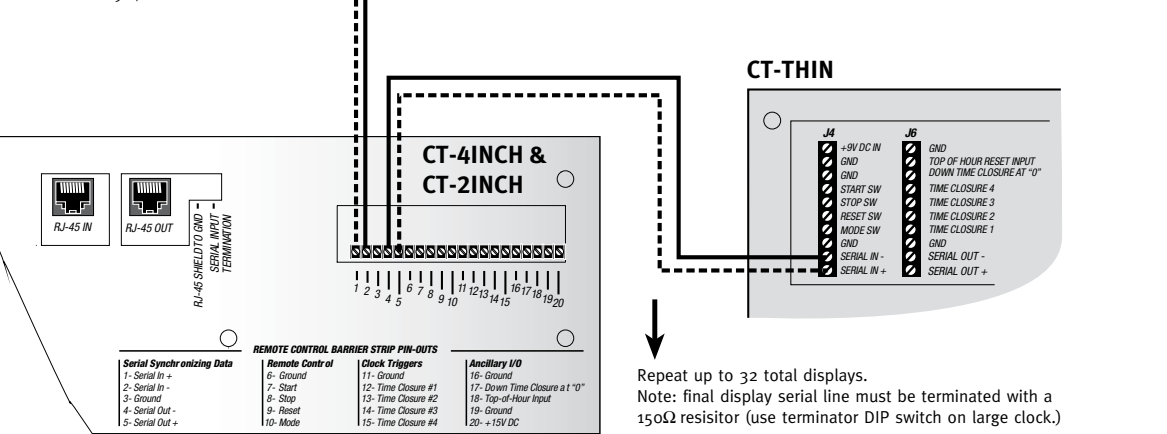
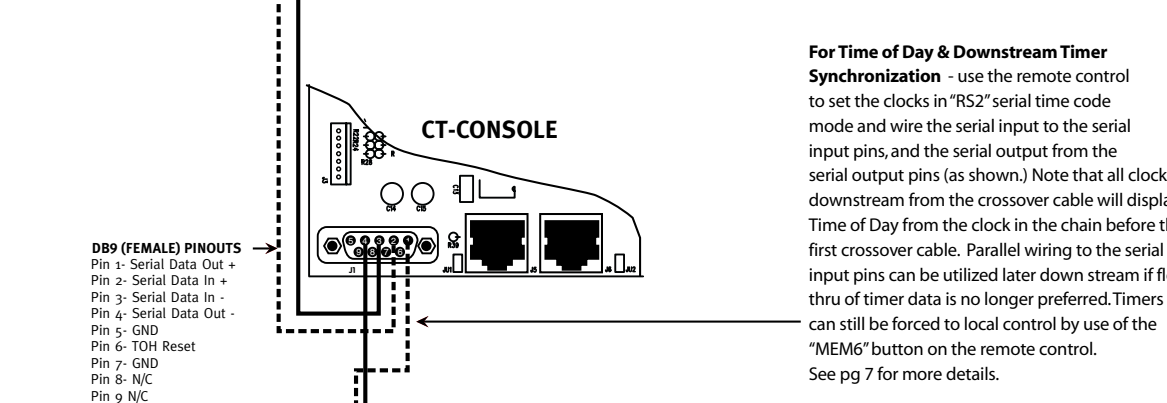
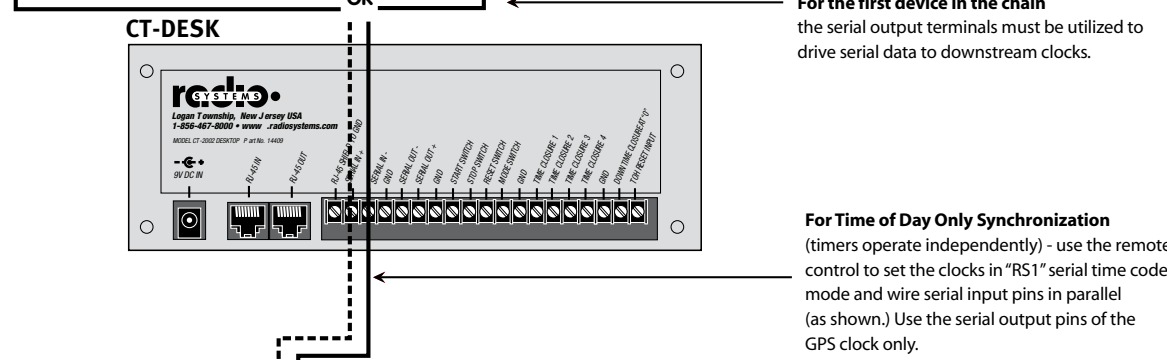
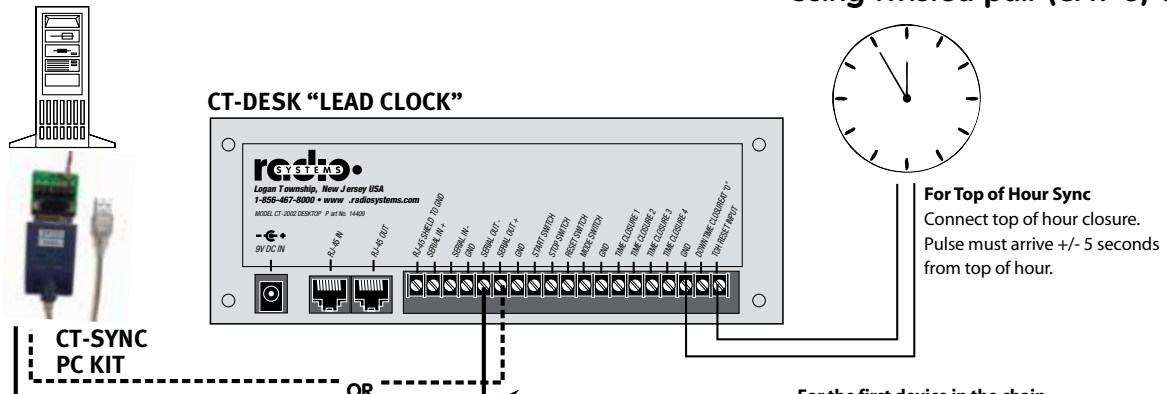

- DB9 (FEMALE) PINOUTS**
- Pin 1- Serial Data Out +
 - Pin 2- Serial Data In +
 - Pin 3- Serial Data In -
 - Pin 4- Serial Data Out -
 - Pin 5- GND
 - Pin 6- TOH Reset
 - Pin 7- GND
 - Pin 8- N/C
 - Pin 9 N/C

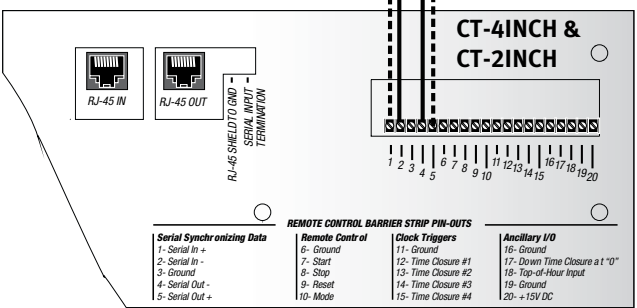

Repeat up to 32 total displays.
 Note: final display serial line must be terminated with a 150Ω resistor (use terminator DIP switch on large clock.)

Master Synchronization via "Lead Clock," Top-of-hour or PC Sync. using RJ-45 patch wire

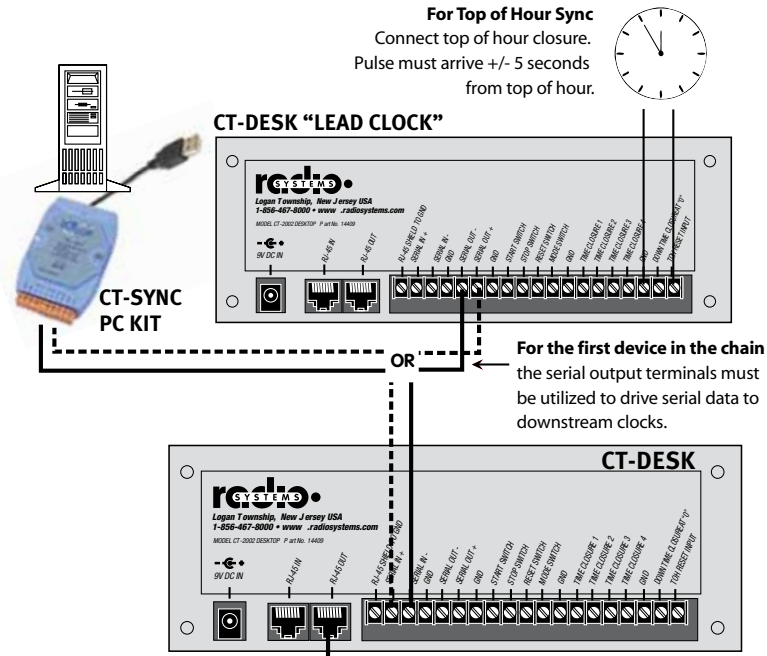

RJ-45 Serial Input Pin-Outs	RJ-45 Serial Output Pin-Outs
1 n/c	1 Serial Out +
2 n/c	2 Serial Out -
3 Serial In +	3 Serial In +
4 Ground	4 Ground
5 Top-of-Hour Reset	5 Top-of-Hour Reset
6 Serial In-	6 Serial In-
7 n/c	7 n/c
8 n/c	8 n/c

NOTE: The serial input terminal are in parallel between the two connectors allowing data to be looped thru to down stream clocks. When looping thru only upstream data will pass (i.e. no local timer data from this clock will flow downstream.)

NOTE: The serial output terminals should be used only when it is desired to pass data from this clock to downstream clocks (i.e. local timer data.)

For Time of Day Only Synchronization → (timers operate independently) - use the remote control to set the clocks in "RS1" serial time code mode and use a **straight thru** patch cable.

For Time of Day & Downstream Timer Synchronization → use the remote control to set the clocks in "RS2" serial time code mode and use a **crossover** patch cable. Note that all clocks downstream from the crossover cable will display Time of Day from the clock in the chain before the first crossover cable. A straight thru cable can be installed later down stream if flow thru of timer data is no longer preferred. Timers can still be forced to local control by use of the "MEM6" button on the remote control. See pg 7 for more details.

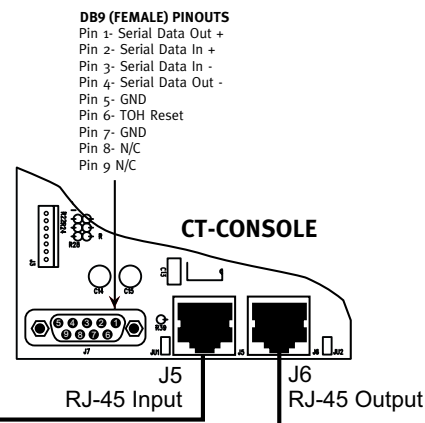

Straight Thru RJ-45 Wiring
For all cables in the chain that use **straight thru** (standard 568B style) patch cords.

PINS 1 THRU 8 ALL CONNECTED.

Cross over RJ-45 Wiring
For all cables in the chain that use **cross over** (standard 568B style) patch cords.

RJ-45 OUT PINS 1 & 2 RJ-45 IN PINS 3 & 6
(Do not use a premade crossover cable. Custom wire with just two wires as shown.)

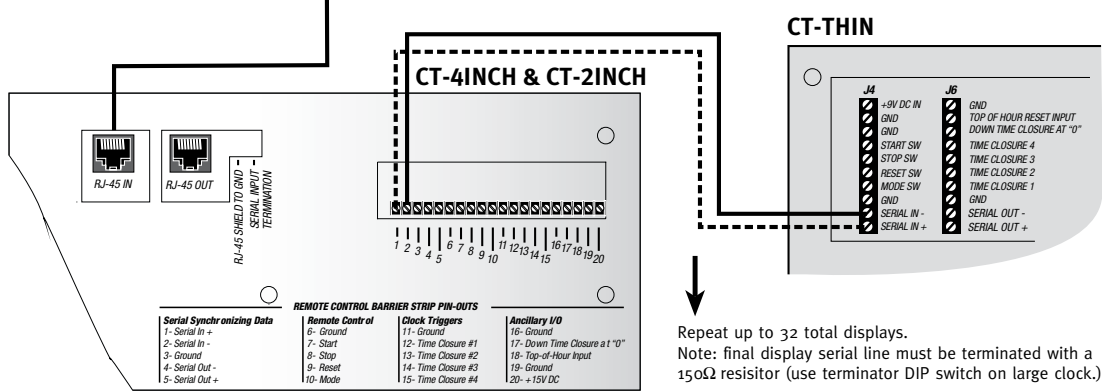

Serial Synchronizing Data	Remote Control	Clock Triggers	Ancillary I/O
1- Serial In +	6- Ground	11- Ground	16- Ground
2- Serial In -	7- Start	12- Time Closure #1	17- Down Time Closure at "0"
3- Ground	8- Stop	13- Time Closure #2	18- Top-of-Hour Input
4- Serial Out -	9- Reset	14- Time Closure #3	19- Ground
5- Serial Out +	10- Mode	15- Time Closure #4	20- +15V DC

Repeat up to 32 total displays.
Note: final display serial line must be terminated with a 150Ω resistor (use terminator DIP switch on large clock.)

Master Synchronization via GPS using twisted pair (CAT-5) wiring

GPS Antenna
See page 23 for Antenna Connection Options

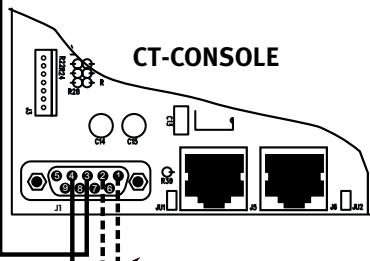
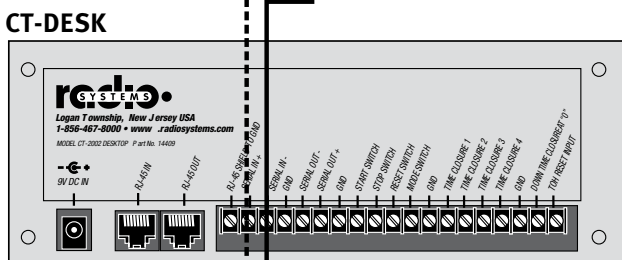
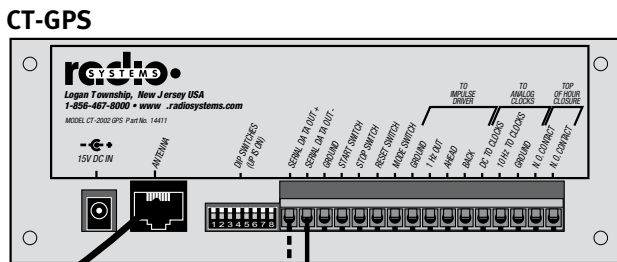

DB9 (FEMALE) PINOUTS
Pin 1- Serial Data Out +
Pin 2- Serial Data In +
Pin 3- Serial Data In -
Pin 4- Serial Data Out -
Pin 5- GND
Pin 6- TOH Reset
Pin 7- GND
Pin 8- N/C
Pin 9 N/C

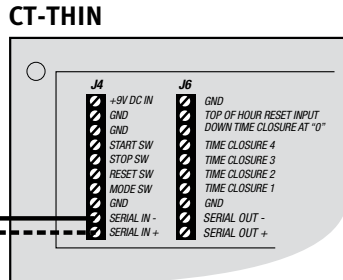
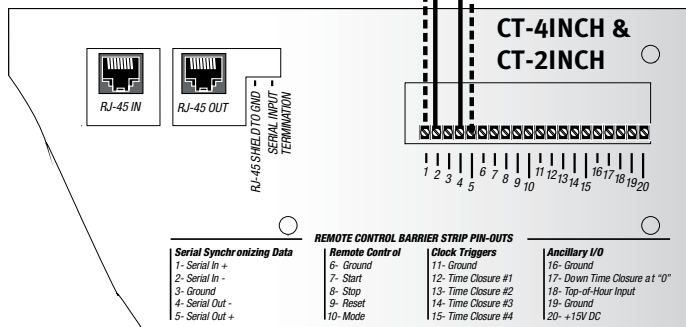

For Time of Day Only Synchronization (timers operate independently) - use the remote control to set the clocks in "RS1" serial time code mode and wire serial input pins in parallel (as shown.) Use the serial output pins of the GPS clock only.

For Time of Day & Downstream Timer Synchronization - use the remote control to set the clocks in "RS2" serial time code mode and wire the serial input to the serial input pins, and the serial output from the serial output pins (as shown.) Note that all clocks downstream from the crossover cable will display Time of Day from the clock in the chain before the first crossover cable. Parallel wiring to the serial input pins can be utilized later down stream if flow thru of timer data is no longer preferred. Timers can still be forced to local control by use of the "MEM6" button on the remote control. See pg 7 for more details.

Repeat up to 32 total displays.
Note: final display serial line must be terminated with a 150Ω resistor (use terminator DIP switch on large clock.)

Master Synchronization via GPS using RJ-45 patch cord wiring

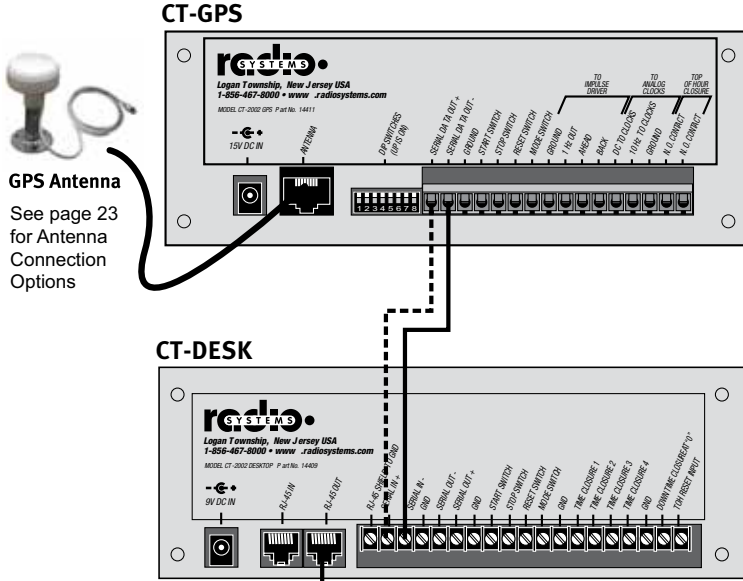

GPS Antenna
See page 23 for Antenna Connection Options

RJ-45 Serial Input Pin-Outs

1	n/c
2	n/c
3	Serial In +
4	Ground
5	Top-of-Hour Reset
6	Serial In -
7	n/c
8	n/c

NOTE: The serial input terminal are in parallel between the two connectors allowing data to be looped thru to down stream clocks. When looping thru only upstream data will pass (i.e. no local timer data from this clock will flow downstream.)

RJ-45 Serial Output Pin-Outs

1	Serial Out +
2	Serial Out -
3	Serial In +
4	Ground
5	Top-of-Hour Reset
6	Serial In -
7	n/c
8	n/c

NOTE: The serial output terminals should be used only when it is desired to pass data from this clock to downstream clocks (i.e. local timer data.)

For Time of Day Only Synchronization → (timers operate independently) - use the remote control to set the clocks in "RS1" serial time code mode and use a **straight thru** patch cable.

For Time of Day & Downstream Timer Synchronization → use the remote control to set the clocks in "RS2" serial time code mode and use a **crossover** patch cable. Note that all clocks downstream from the crossover cable will display Time of Day from the clock in the chain before the first crossover cable. A straight thru cable can be installed later down stream if flow thru of timer data is no longer preferred. Timers can still be forced to local control by use of the "MEM6" button on the remote control. See pg 7 for more details.

DB9 (FEMALE) PINOUTS

Pin 1	Serial Data Out +
Pin 2	Serial Data In +
Pin 3	Serial Data In -
Pin 4	Serial Data Out -
Pin 5	GND
Pin 6	TOH Reset
Pin 7	GND
Pin 8	N/C
Pin 9	N/C

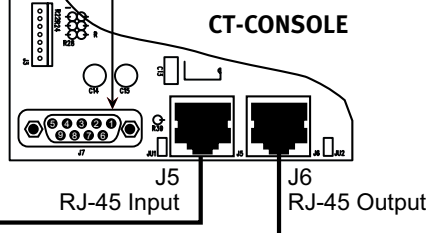

Straight Thru RJ-45 Wiring

For all cables in the chain that use **straight thru** (standard 568B style) patch cords.

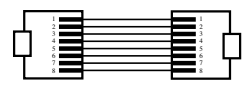

PINS 1 THRU 8 ALL CONNECTED.

Cross over RJ-45 Wiring

For all cables in the chain that use **cross over** (standard 568B style) patch cords.

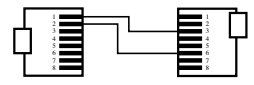

RJ-45 OUT PINS 1 & 2 RJ-45 IN PINS 3 & 6
(Do not use a premade crossover cable. Custom wire with just two wires as shown.)

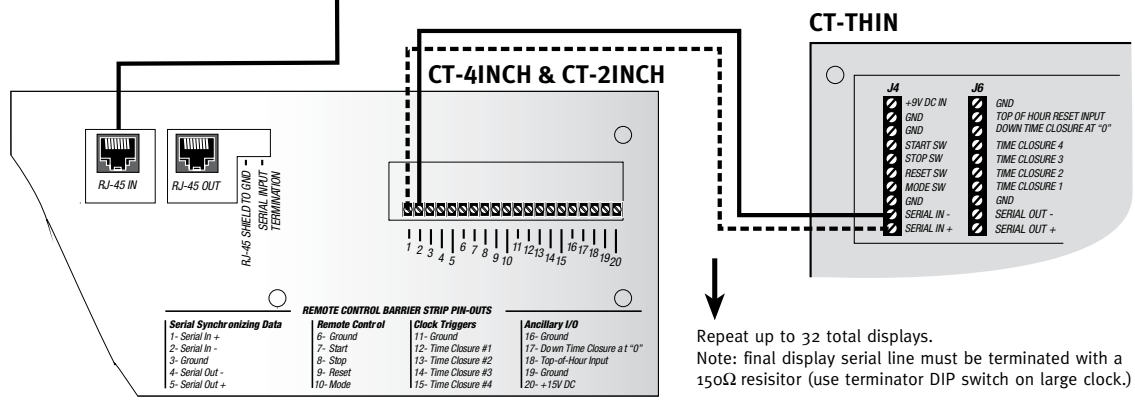

REMOTE CONTROL BARRIER STRIP PIN-OUTS

Serial Synchronizing Data	Remote Control	Clock Triggers	Ancillary I/O
1- Serial In +	6- Ground	11- Ground	16- Ground
2- Serial In -	7- Start	12- Time Closure #1	17- Down Time Closure at "0"
3- Ground	8- Stop	13- Time Closure #2	18- Top-of-Hour Input
4- Serial Out -	9- Reset	14- Time Closure #3	19- Ground
5- Serial Out +	10- Mode	15- Time Closure #4	20- +15V DC

Repeat up to 32 total displays.
Note: final display serial line must be terminated with a 150Ω resistor (use terminator DIP switch on large clock.)

Remote Control Connections

CT-GPS

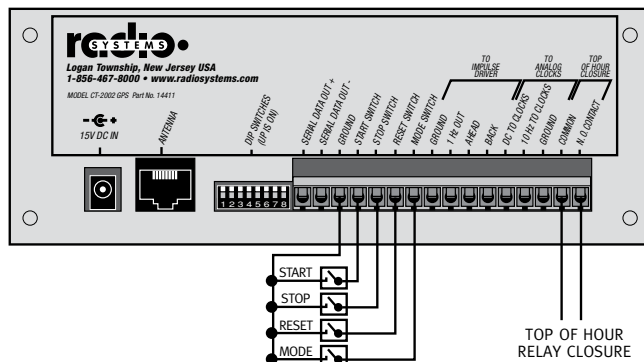

CT-DESK

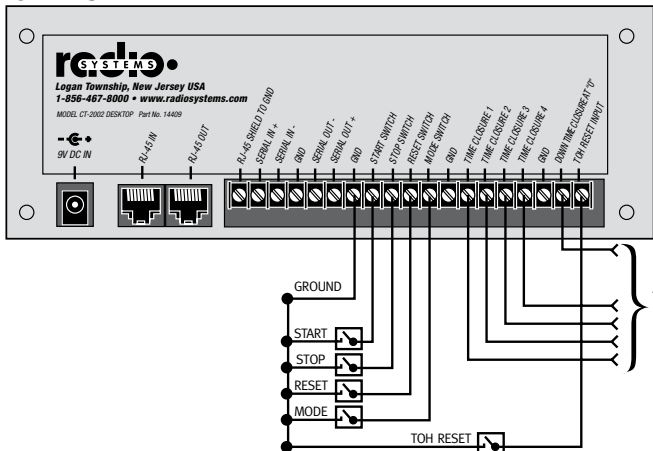

CT-THIN

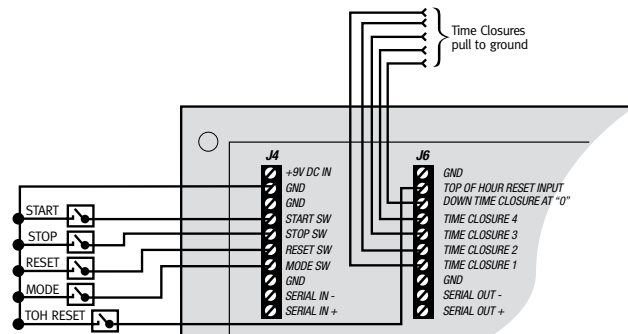

To recalled stored memory positions 1 thru 6 via wired remote:
Wire to remote terminals shown for Thin/Desktop/2" & 4" models.
Note that steering diodes (not supplied) must be installed.

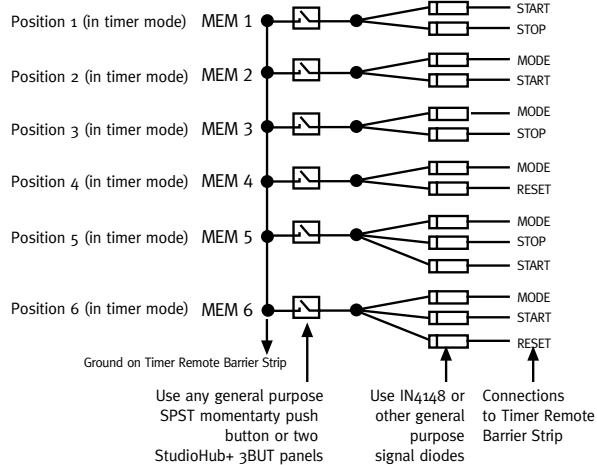

CT-4INCH & CT-2INCH

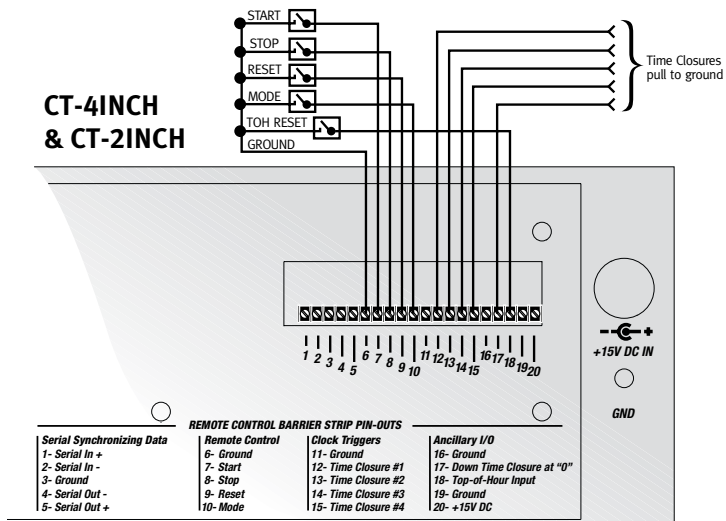

CT-2002 GPS Antenna Wiring Options

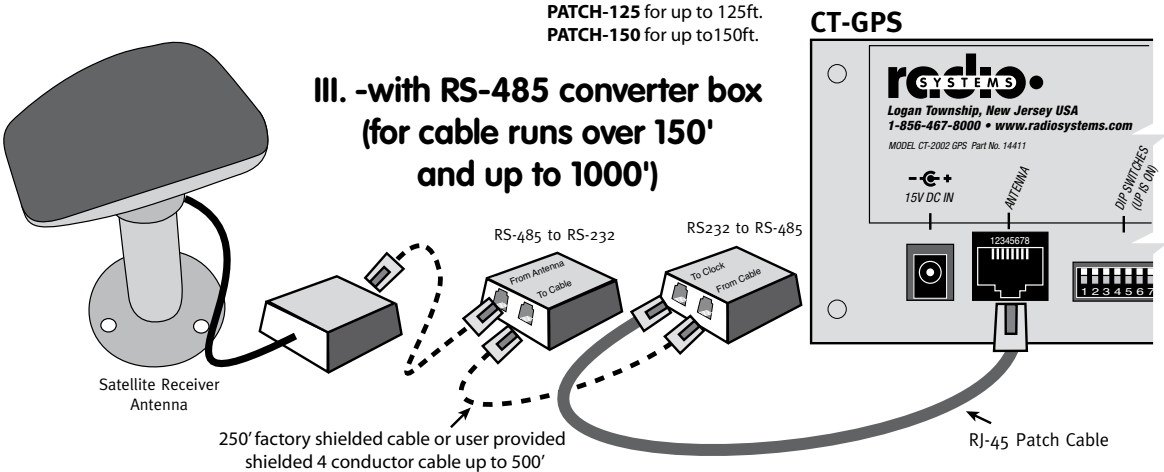
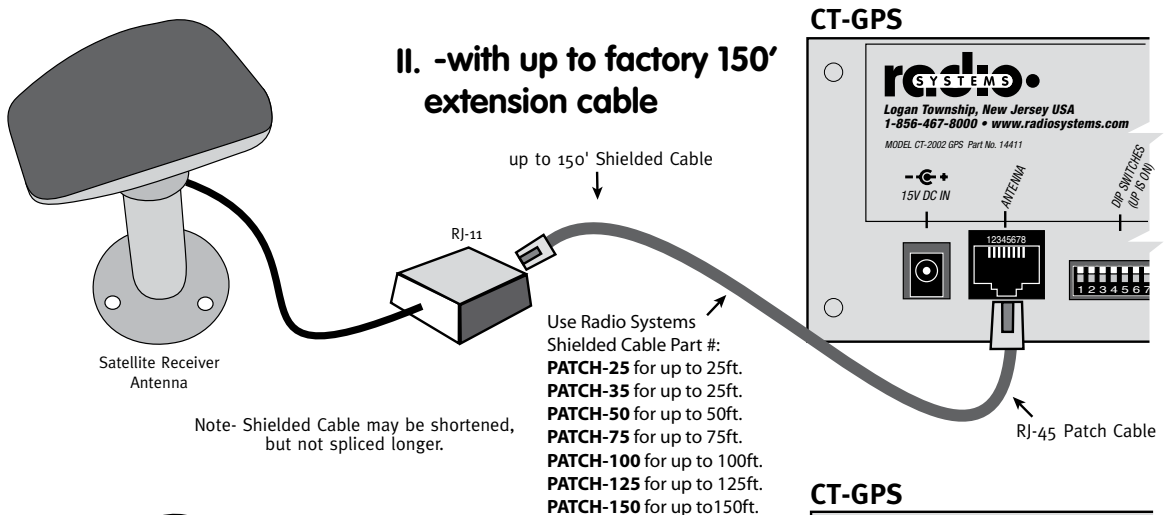
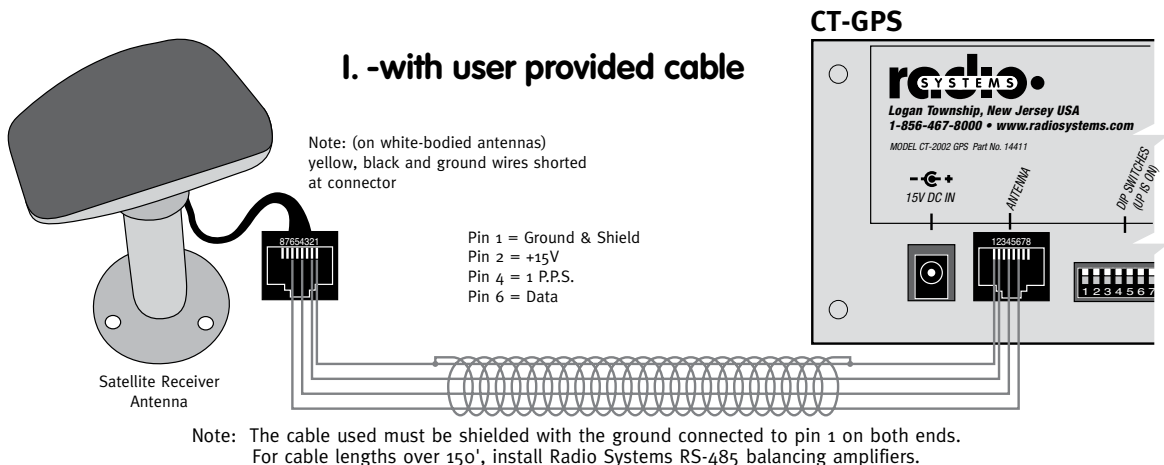

CT-2002 GPS DIP Switch Settings

CT-GPS

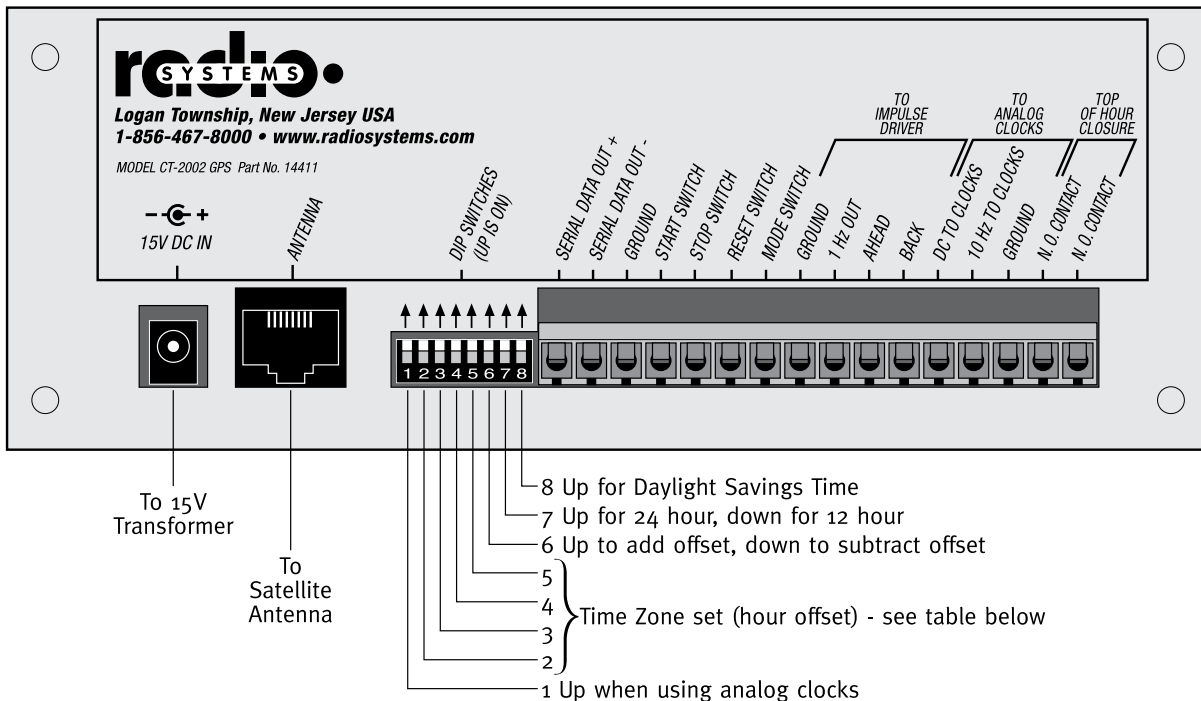

Hour Offset Table

Hour Offset (from GMT)	Dip Switch #			
	2	3	4	5
0	OFF	OFF	OFF	OFF
1	OFF	OFF	OFF	ON
2	OFF	OFF	ON	OFF
3	OFF	OFF	ON	ON
4	OFF	ON	OFF	OFF
5	OFF	ON	OFF	ON
6	OFF	ON	ON	OFF
7	OFF	ON	ON	ON
8	ON	OFF	OFF	OFF
9	ON	OFF	OFF	ON
10	ON	OFF	ON	OFF
11	ON	OFF	ON	ON
12	ON	ON	OFF	OFF

Sample Settings

(Shown programmed for 12 hour display, no analog clocks and daylight savings time)

Eastern Daylight Savings Time

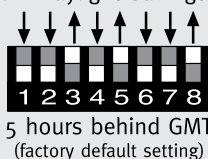

Central Daylight Savings Time

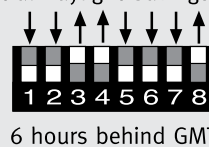

Mountain Daylight Savings Time

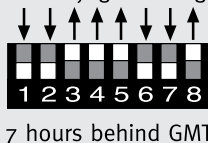

Pacific Daylight Savings Time

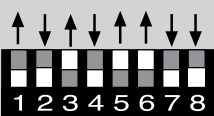
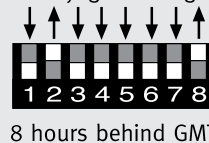

India (New Delhi) Time
 5 1/2 hours ahead of GMT
 (No Daylight Savings/12 hour/
 Analog Clocks connected)

Note:
 Special software prom p/n 16119 required.
 Prom adds 1/2 hour to all time offset settings.

Warranty

Radio Systems, Inc., warrants this equipment to be free from defects in materials and workmanship for a period of one (1) year.

This warranty extends to first users of the product and future owners who purchase the product within the warranty period.

The terms of this warranty are null and void if this product is stored or operated in an environment not conducive to electronic equipment, or shows signs of misuse or modifications which affect the proper functioning of the product. This warranty does not apply to damage caused by fire, smoke, flood, lightning, or acts of nature and physical abuse.

Radio Systems, Inc., and its associated companies, authorized distributors, and personnel are not liable for loss of revenues or other damages, or effects to the broadcast signal quality or coverage which may result from the improper functioning of this product.

Repair Policy

Technical assistance is available at any time, at no charge, by phone or correspondence.

During the warranty period, there will be no charge for parts or service made to units which show no sign of misuse by customer or lightning caused damage. The customer is responsible for the cost of shipping their unit back to Radio Systems for repair.

During the warranty period, shipment of small parts and assemblies may also be made at a charge to the user. Emergency shipments of replacement parts and circuits will be made at the user's request for an extra shipping and service charge. Chargeable services will be made COD or on Net-30 day terms to users with established accounts.

During the warranty period, full credit or return of COD charges (less any service and expedited shipping charges) will be made to users who return the defective parts or circuits within 30 days, if the damage is covered under the terms of the warranty.

Return Instructions

Contact Radio Systems for a return authorization number.

Pack all items carefully and ship prepaid, via UPS insured, to:

Radio Systems, Inc.

Attn: R.A. # _____

601 Heron Drive

Logan Township, New Jersey 08085-1741

Enclose a note which includes your name, company, phone number, the serial number, return address (no box numbers), and a complete description of the problem.



(856) 467-8000 • Fax (856) 467-3044
601 Heron Drive • Logan Township, New Jersey 08085 • www.radiosystems.com