

LIMITED WARRANTY

This product is warranted to the original consumer purchaser to be free from defects in materials and workmanship under normal installation, use and service for a period of one (1) year from the date of purchase as shown on the purchaser's receipt.

The obligation of Rolls Corporation under this warranty shall be limited to repair or replacement (at our option), during the warranty period of any part which proves defective in material or workmanship under normal installation, use and service, provided the product is returned to Rolls Corporation, TRANSPORTATION CHARGES PREPAID. Products returned to us or to an authorized Service Center must be accompanied by a copy of the purchase receipt. In the absence of such purchase receipt, the warranty period shall be one (1) year from the date of manufacture.

This warranty shall be invalid if the product is damaged as a result of defacement, misuse, abuse, neglect, accident, destruction or alteration of the serial number, improper electrical voltages or currents, repair, alteration or maintenance by any person or party other than our own service facility or an authorized Service Center, or any use violative of instructions furnished by us.

This one-year warranty is in lieu of all expressed warranties, obligations or liabilities. ANY IMPLIED WARRANTIES, OBLIGATIONS, OR LIABILITIES, INCLUDING BUT NOT LIMITED TO THE IMPLIED WARRANTIES OF MERCHANTABILITY AND FITNESS FOR A PARTICULAR PURPOSE, SHALL BE LIMITED IN DURATION TO THE ONE YEAR DURATION OF THIS WRITTEN LIMITED WARRANTY. Some states do not allow limitations on how long an implied warranty lasts, so the above limitation may not apply to you.

IN NO EVENT SHALL WE BE LIABLE FOR ANY SPECIAL, INCIDENTAL OR CONSEQUENTIAL DAMAGES FOR BREACH OF THIS OR ANY OTHER WARRANTY, EXPRESSED OR IMPLIED, WHATSOEVER. Some states do not allow the exclusion or limitation of special, incidental or consequential damages so the above limitation or exclusion may not apply to you. This warranty gives you specific legal rights, and you may also have other rights which vary from state to state.

ROLLS

MA1705 Mixer / 70 Volt Amplifier



ROLLS CORPORATION
SALT LAKE CITY, UTAH
2/04

OWNERS MANUAL

Thank your for your purchase of the Rolls MA1705 Mixer / Amplifier. The MA1705 is a two rack space mixer amplifier designed for restaurants, schools, churches, clubs etc. The unit provides a compact and efficient way to mix up to three sources such as AM/FM tuners, CD players, and video players with up to two microphones. Priority talkover is provided on Microphone Two for paging, and on Source One for a jukebox, telephone, etc. The power output section is to be connected to a 70 Volt system.

NOTE: THIS MANUAL ASSUMES THE USER HAS A WORKING KNOWLEDGE OF AUDIO ELECTRONICS, BALANCED AND UNBALANCED CONNECTIONS, AND PROPER SIGNAL LEVEL SETTING.

INSPECTION

1. Unpack and inspect the MA1705 box and package. If obvious physical damage is noticed, contact the carrier immediately to make a damage claim. We suggest saving the shipping carton and packing materials for safely transporting the unit in the future.
2. Please visit our website at www.rolls.com and click on the Register Your Warranty Here button, or complete the Warranty Registration Card and return it to the factory.

TABLE OF CONTENTS

Introduction	1
Inspection	1
Table of Contents	1
Description	2
Connection	3
Operation	4
Specifications	5
Schematic	6
Warranty	Back Cover

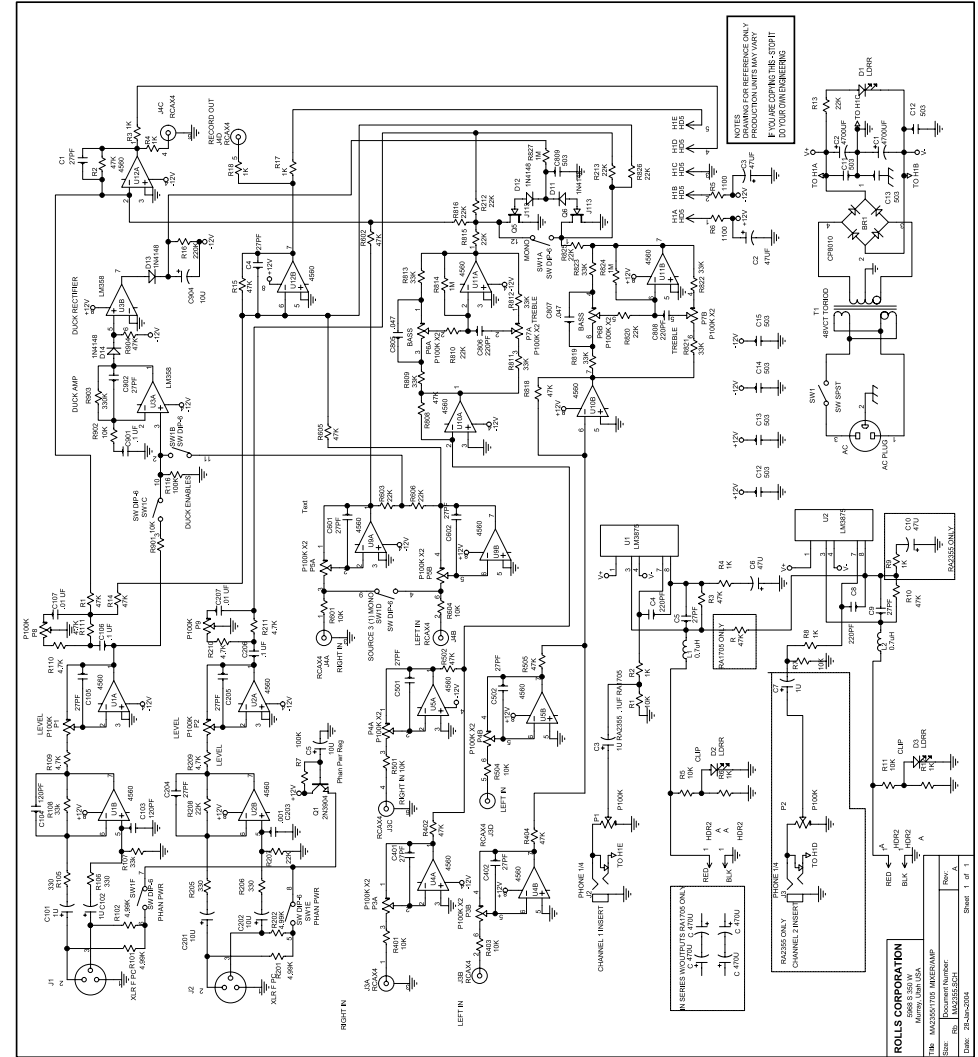

SPECIFICATIONS

MIXER

Input Impedance:	Mic: 600 Ohms XLR balanced Source: 22K Ohms RCA Insert: 22K Ohms 1/4" TS unbal.
Max Input Level:	Mic: -14 dBV Mic level Max Source: 24 dBV Insert: 24 dBV
Connectors:	2: XLR, 6: Stereo RCA, 3: 1/4" TRS, 1: 1/4" TS
Phantom Power:	+12 VDC
Max Gain:	Mic: 60 dBV Source: 26 dBV
Tone Controls:	+/-12 dB 100 Hz Bass +/-12 dB 11kHz Treble
Noise Floor:	Speaker Out: -67 dBV Pre Out: -90 dBV
THD + Noise:	-82 dBV
S/N Ratio:	96 dBV
Priority Attenuation:	60 dBV

POWER AMP

Recommended Load:	70 Volt line (70 Watts maximum)
Frequency Response:	60Hz to 20 kHz
Size (W x H x D):	19" x 1.75" x 5" (48 x 4.5 x 12.7)
Weight:	5.5 lbs (2.5 kg)

DESCRIPTION

FRONT PANEL



Mic 1, 2: Adjust the level of signal from the corresponding Mic Input.
TONE 1, 2: Adjusts the frequency content of the microphone signal in the channel. When the control is turned counter-clockwise, the high frequencies are cut, when the control is turned clockwise, the low frequencies are cut.
Source 1 - 3: Adjust the volume of input from the RCA Source Inputs.
Bass: Adjusts the low frequencies of the Source 2 and 3 signals only.
Treble: Adjusts the high frequencies of the Source 2 and 3 signals only.
Output Level: Adjusts the output level of the MA1705 amplifier.
Power: LED indicating power is applied to the MA1705 and the unit is on.
Clip. LED indicating overload in the MA1705 amplifier.

REAR PANEL

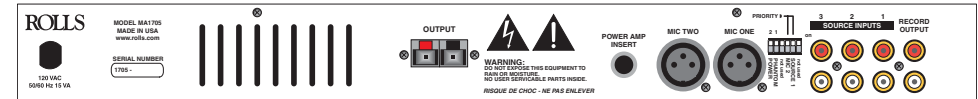

OUTPUT: Spring-loaded terminal for connection to the speakers.
POWER AMP INSERT: 1/4" Tip-Send, Ring-Return insert jack for.
MICROPHONE ONE and TWO: Balanced XLR inputs to be connected to dynamic or condenser microphones.
DIP SWITCH: Contains the small switches for engaging Mic 1, 2 phantom power, and the priority (Talk Over) functions.
SOURCE INPUTS: Stereo RCA jacks, Channels 1 - 3, for connection to stereo sources such as AM/FM tuners, cassette players, cd players, or a jukebox.
RECORD OUT: Stereo RCA jacks, contains all mixed signals before the Master Level control.

Inputs

Connect low impedance microphones to the Mic inputs. If a paging microphone is being used, connect it to Mic Input 2 so it may be used with the Talk Over function. Connect source signals such as CD players, cassette players or video players to the RCA Source Inputs. If a jukebox is being connected, and you want its signal to mute the other source signals, connect it to Source input 1.

For recording purposes, connect a stereo RCA cable to the Record Out jacks, and to your recording device.

Amp Insert

To connect a signal processor to the MA1705 signal, use an insert plug, or cable wired as shown in Fig. 1. This return signal is then sent to the output level section of the amplifier.

Output

Connect 70 Volt speakers to the Output of the MA1705 by pressing in each of the spring-loaded terminals and inserting the proper wire into the proper terminal i.e.; + = red, - = black.

Connect the MA1705 to a properly grounded AC outlet.

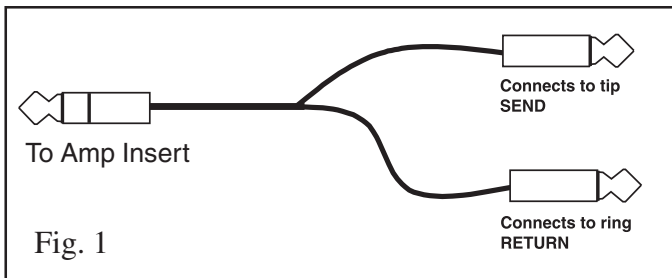
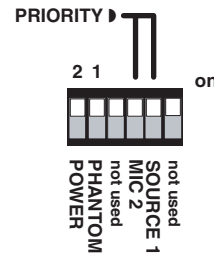

Fig. 1

DIP SWITCH SETTINGS (From left to right)



- If a microphone requires phantom power, move the Mic channel's corresponding PHANTOM POWER switch to the up position. This applies 12 volts dc phantom power to the indicated microphone.
- Mic 2 Priority; when in the up position, all program material on Mic 1 and Sources 2 and 3 will be "ducked" or muted when a signal is present at Mic 2. Source 1 is left un-muted. This function is used for paging.
- Source 1 Priority: when in the up position, Source 2, and 3 will be "ducked" or muted by the signals at Source 1. This function is for jukebox priority. With a jukebox connected to Source input 1, and the Talkover switch 2 on, the other Source input signals such as background music, will be muted and only the jukebox will be heard.

FAULT PROTECTION

The fault protection in the MA1705 limits the current to the output stage. This mode is entered whenever the output stage is called upon for too much power, it may also be fooled by impedances lower than four ohms - which may cause the output stage to overheat and be irreversibly damaged.

BURN WARNING!

THE FRONT PANEL OF THE MA1705 IS THE HEAT DISTRIBUTION FOR THE OUTPUT STAGE. IF THE UNIT IS OPERATED AT HIGH VOLUMES, IT MAY GET HOT.