

# Collapsible Reel Assembly Instructions

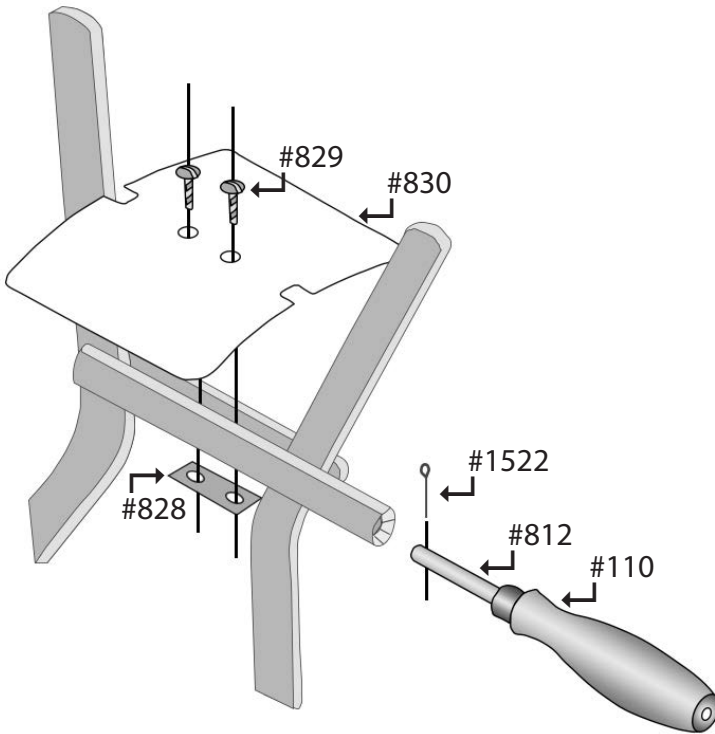

Part #	Description	Quantity
#110	Wooden Handle	1
#812	Handle Shaft Assembly	1
#828	Nut	5
#829	Screw #10 x 1-1/4"	10
#830	Radius Plate	5
#1522	Cotter Pin 3/32" x 1/2"	1

## Radius Plates

Place the #830 radius plate between arms so that the indented portion of the plate is secure on each side. Insert two (2) #829 screws on the outside of the radius plate, the screws should be between the crossbar arm supports. Tighten screws into the #828 nut located on the opposite side of the crossbar arm supports.

## Handle

Insert the #812 shaft assembly into the wooden part of the #110 handle so that it is flush against the flat part of the wooden handle. Insert the full handle assembly (#110 and #812) into the small circular opening on the collapsible reel. Insert the #1522 cotter pin on the end of the #812 shaft assembly, locking it into place.

Thank you very much for choosing SpoolMaster products. Please contact us should you have any questions or concerns, or if additional information and instructions are required. Contact information is below:



Phone: 310-822-6290 | Fax: 310-306-9343

Email: [info@spoolmaster.com](mailto:info@spoolmaster.com)

Website: [www.spoolmaster.com](http://www.spoolmaster.com)

Address: P.O. Box 12017 Marina del Rey, CA 90292

Hours: Monday - Friday 8:00am - 4:30pm Pacific Time

# Collapsible Reel Operating Instructions

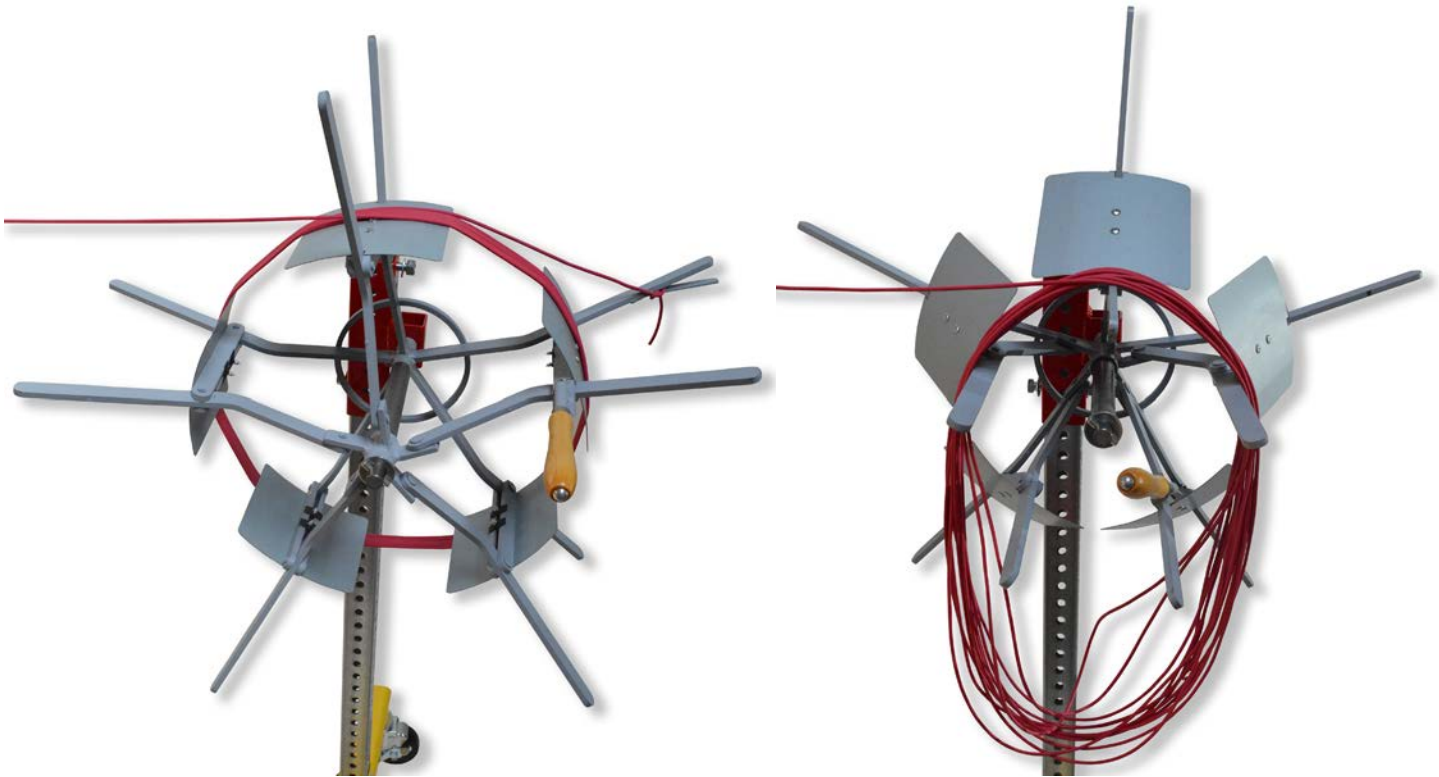

## Unloading/Offloading Coiled Material

Tie coiled material in at least two (2) places (between arms) before collapsing the reel. Collapse the reel by grasping opposite arms and pressing them toward the reel hub. Offload/remove the coiled material to the front of the reel. Return the reel to the starting position by applying reverse pressure on opposite arms until the sliding hub comes to rest against the washer and pin at the front of the shaft.

Thank you very much for choosing SpoolMaster products. Please contact us should you have any questions or concerns, or if additional information and instructions are required. Contact information is below:



**Phone:** 310-822-6290 | **Fax:** 310-306-9343

**Email:** [info@spoolmaster.com](mailto:info@spoolmaster.com)

**Website:** [www.spoolmaster.com](http://www.spoolmaster.com)

**Address:** P.O. Box 12017 Marina del Rey, CA 90292

**Hours:** Monday - Friday 8:00am - 4:30pm Pacific Time