

---

## General Description

The Shure ANI22 Audio Network Interface provides 2 channels of Dante-to-analog and 2 channels of analog-to-Dante conversion. A single interface provides a simple way to connect analog equipment to the audio network, such as wireless microphones, audio processors, video codecs, and loud-

speaker systems. Available in XLR and block connector versions, each box uses a single network cable to carry audio and power through Power over Ethernet (PoE). A browser-based web application controls audio and network settings from any computer connected to the same network.

---

## Safety Information

### IMPORTANT SAFETY INSTRUCTIONS

1. READ these instructions.
2. KEEP these instructions.
3. HEED all warnings.
4. FOLLOW all instructions.
5. DO NOT use this apparatus near water.
6. CLEAN ONLY with dry cloth.
7. DO NOT block any ventilation openings. Allow sufficient distances for adequate ventilation and install in accordance with the manufacturer's instructions.
8. DO NOT install near any heat sources such as open flames, radiators, heat registers, stoves, or other apparatus (including amplifiers) that produce heat. Do not place any open flame sources on the product.
9. DO NOT defeat the safety purpose of the polarized or grounding type plug. A polarized plug has two blades with one wider than the other. A grounding type plug has two blades and a third grounding prong. The wider blade or the third prong are provided for your safety. If the provided plug does not fit into your outlet, consult an electrician for replacement of the obsolete outlet.
10. PROTECT the power cord from being walked on or pinched, particularly at plugs, convenience receptacles, and the point where they exit from the apparatus.
11. ONLY USE attachments/accessories specified by the manufacturer.
12. USE only with a cart, stand, tripod, bracket, or table specified by the manufacturer, or sold with the apparatus. When a cart is used, use caution when moving the cart/apparatus combination to avoid injury from tip-over.



13. UNPLUG this apparatus during lightning storms or when unused for long periods of time.
14. REFER all servicing to qualified service personnel. Servicing is required when the apparatus has been damaged in any way, such as power supply cord or plug is damaged, liquid has been spilled or objects have fallen into the apparatus, the apparatus has been exposed to rain or moisture, does not operate normally, or has been dropped.
15. DO NOT expose the apparatus to dripping and splashing. DO NOT put objects filled with liquids, such as vases, on the apparatus.
16. The MAINS plug or an appliance coupler shall remain readily operable.
17. The airborne noise of the Apparatus does not exceed 70dB (A).
18. Apparatus with CLASS I construction shall be connected to a MAINS socket outlet with a protective earthing connection.
19. To reduce the risk of fire or electric shock, do not expose this apparatus to rain or moisture.
20. Do not attempt to modify this product. Doing so could result in personal injury and/or product failure.
21. Operate this product within its specified operating temperature range.

	This symbol indicates that dangerous voltage constituting a risk of electric shock is present within this unit.
	This symbol indicates that there are important operating and maintenance instructions in the literature accompanying this unit.

---

## Getting Started

This device features a browser-based web application, which controls audio and network properties. Upon completing this basic setup process, you will be able to:

- Access the web application to customize audio settings and network properties
- Use Dante™ Controller software to connect with other Dante devices and pass audio
- Access additional configuration information

### Step 1: Connect to a Network

1. Use an Ethernet cable (CAT5e or higher) to connect the ANI22 to a network switch.

**Note:** The network switch must provide Power over Ethernet (PoE). Make sure to connect to a PoE port, since many switches do not supply power on all ports.

2. Connect a computer to the network switch with an Ethernet cable

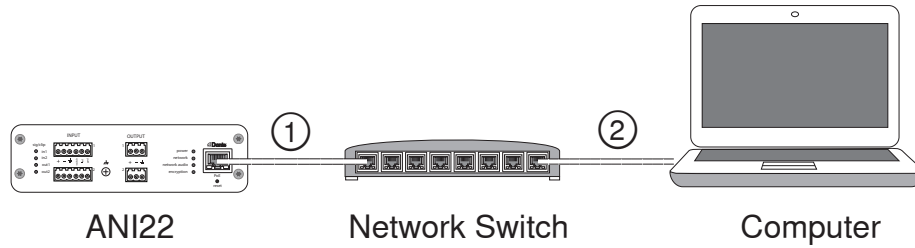

### Step 2: Access the Web Application

1. Download and install the **Shure Device Discovery application** (<http://www.shure.com>)
2. Open the Shure Device Discovery application
3. Double-click the device to open the web application.

**Tip:** If setting up multiple Shure devices, use the Identify button in the application to flash the lights on the device.

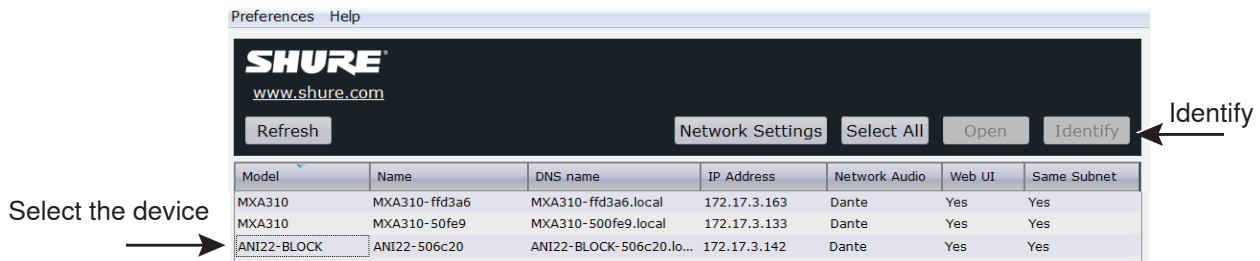

### Step 3: Connect Devices in Dante Controller Software

1. Download and install Dante Controller Software from <http://www.audinate.com>
2. Use Dante Controller to create connections with other Dante devices

**Note:** Refer to the Dante Controller user guide for more information on channel routing (available at <http://www.audinate.com/resources/technical-documentation>)

#### Example: Connecting the ANI22 and Shure MXA310

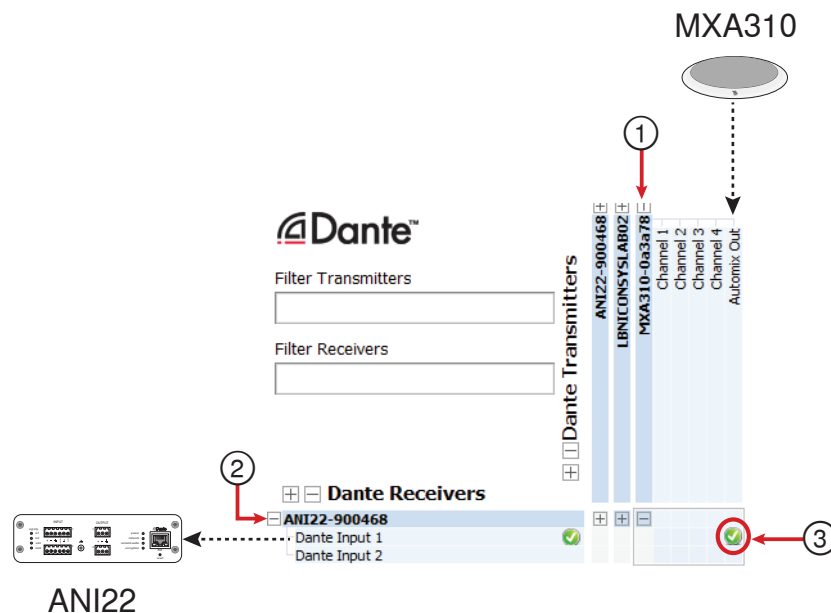

1. Find the MXA310 in the list of Dante transmitters, and select the plus sign (+) to show all channels.
2. Find the ANI22 in the list of Dante receivers, and select the plus sign (+) to show all channels.
3. Check the box where the MXA310 **AUTOMIX OUT** and the ANI22 **DANTE INPUT 1** intersect

## Step 4: Configure Audio

1. Connect analog equipment (such as loudspeakers or wireless microphone systems) to the analog inputs and outputs. Refer to the hardware section in this guide for information on connections and LED metering.
2. In the ANI22 web application, adjust input and output levels and perform a sound check. Refer to the help topics in the web application for additional information.

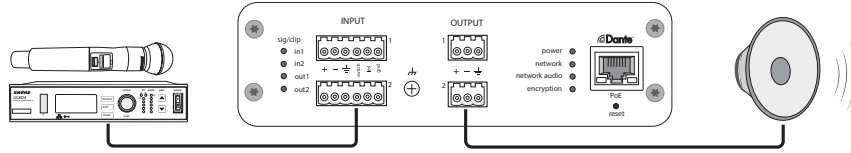

Access the help section

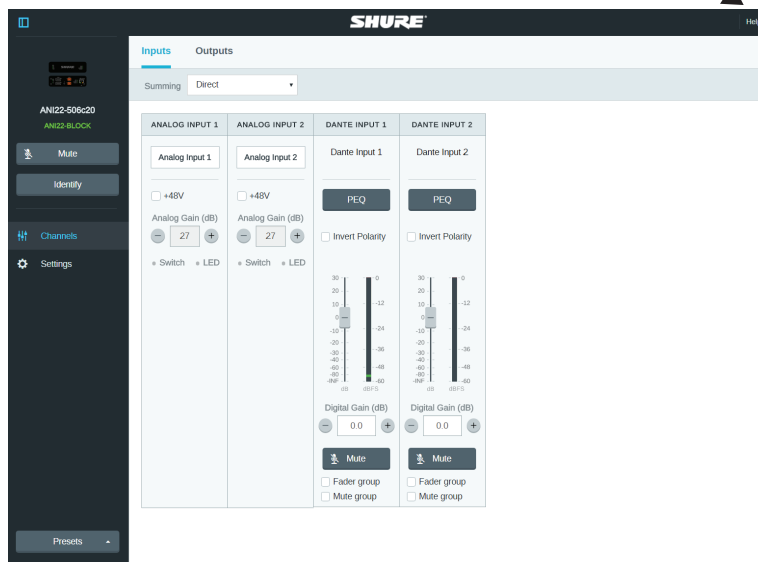

## Get More Information

Now that the basic setup is complete, you should have access to the web application and be able to pass audio between devices. More comprehensive information is available online and in the help section, including:

- Maximizing audio quality with the built-in parametric equalizer
- External control system command strings
- System scenario diagrams
- Software configuration
- Networking information
- Troubleshooting
- Replacement parts and accessories

The complete user guide is available at <http://pubs.shure.com/guide/ANI22>

## Hardware and Installation

### Hardware

**Block Connector Model:**

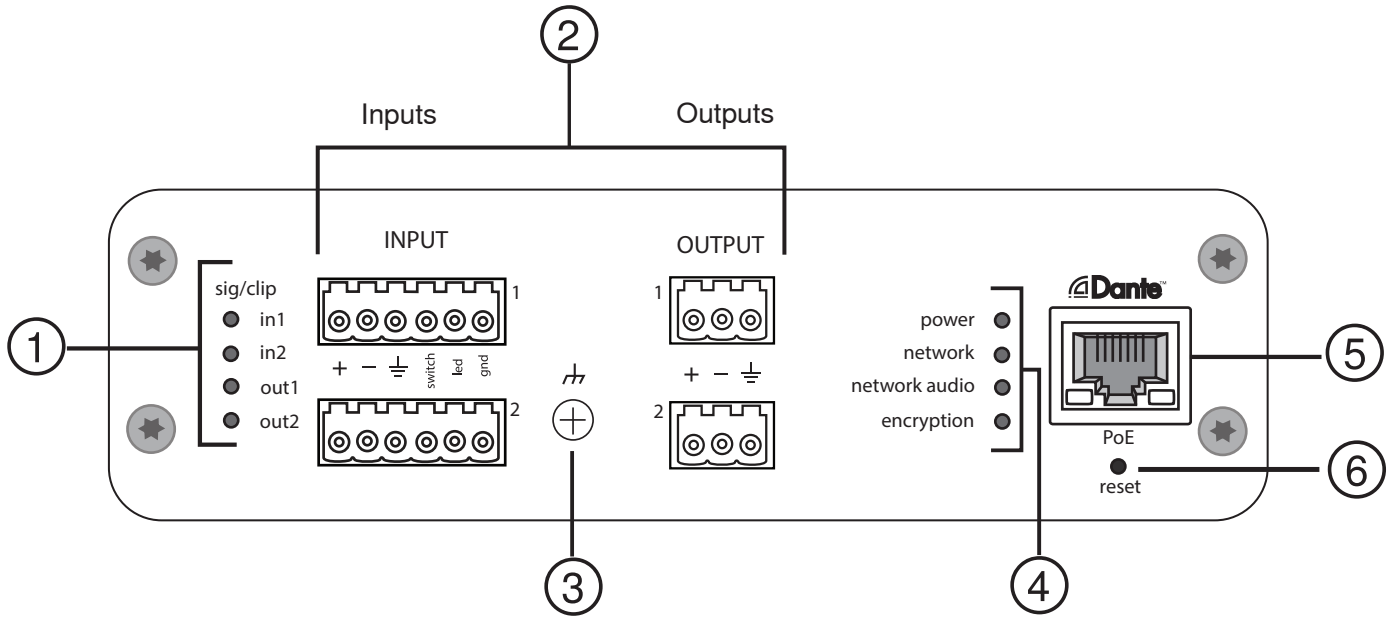

**XLR Model:**

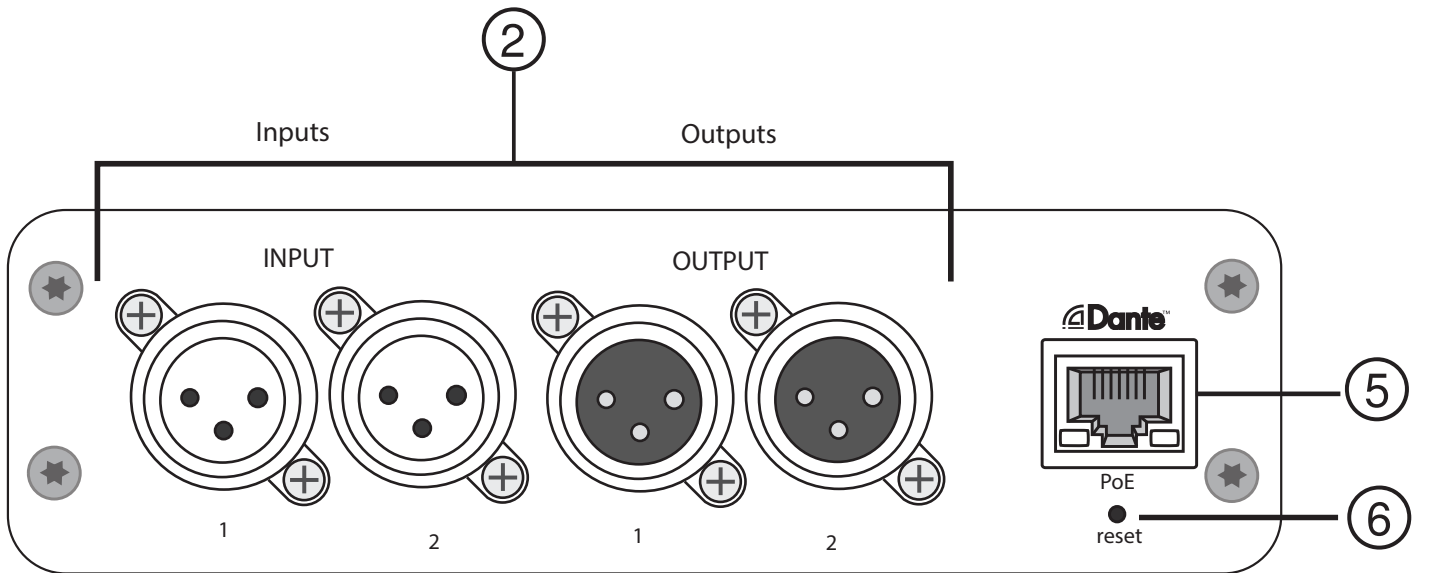

**① Signal/Clip Indicators**

Each indicator corresponds to a single channel. Analog and digital gain adjustments are made through the web application.

- If an input channel LED turns red, attenuate the level from the source device to prevent clipping at the input stage.
- If an output channel LED turns red, lower the corresponding Digital Gain (dB) fader for the Dante channel under the Input Channels tab. Do not lower the output level (line/aux/mic), as any clipping indicated on the LED occurs before the final output level stage.

LED State	Audio Signal Level
Off	less than -60 dBFS
Green	-60 dBFS to -18 dBFS
Yellow	-18 dBFS to -6 dBFS
Red	-6 dBFS or more

**② Audio and Logic Connections**

**Note:** Logic connections are only featured on the block connector version.

**Block Connector Pin Assignments:**

+	Audio +
-	Audio -
	Audio ground
<b>switch</b>	Logic Mute (sent from microphone)
<b>led</b>	Logic LED (received by microphone)
<b>gnd</b>	Logic ground

+	Audio +
-	Audio -
	Audio ground

**XLR Pin Assignments:**

1	Ground
2	Positive
3	Negative

③ **Chassis Ground Screw**

Provides an optional connection for microphone shield wire to chassis ground.

④ **LED Indicators**

**Power:** Power over Ethernet (PoE) present

**Note:** Use a PoE injector if your network switch does not supply PoE.

**Network:** Network connection active

**Network Audio:** Dante™ audio present on the network

**Note:** Error details are available in the event log in the web application.

LED Status	Activity
Off	No active signal
Green	Device is operating successfully
Red	Error has occurred. See event log for details.

**Encryption:**

LED Status	Activity
Off	Audio not encrypted
Green	Successful encrypted audio connection with another device
Red	Encryption error. Possible causes: Encryption is enabled on one device and not on another Passphrase mismatch

⑤ **Dante Network Port**

Connects to a network switch to send Dante™ audio, while receiving Power over Ethernet (PoE) and data from the control software. See the Dante and networking section for additional information.

### ⑥ Reset Button

Resets the device settings back to the factory default.

## Power Over Ethernet (PoE)

Power Over Ethernet

This device requires PoE to operate. It is compatible with both **Class 0** and **Class 3** PoE sources.

Power over Ethernet is delivered in one of the following ways:

- A network switch that provides PoE
- A PoE injector device

## Reset

The reset button is located inside a small hole in the rear panel. Use a paperclip or other small tool to press the button.

There are two hardware reset functions:

### Network reset (press button for 4-8 seconds)

Resets all Shure control and audio network IP settings to factory defaults

### Full factory reset (press button for longer than 8 seconds)

Restores all network and web application settings to the factory defaults.

## Software Reset Options

To simply revert settings without a complete hardware reset, use one of the following options:

**Reboot Device:** In the web application (settings > factory reset), there is a Reboot Device button, which simply power-cycles the device as if it were unplugged from the network. All settings are retained when the device is rebooted.

**Default Settings:** To revert audio settings back to the factory configuration (excluding Device Name, IP Settings, and Passwords), select Load Preset and choose the default settings preset.

## Installation and Rack Mounting

Two mounting solutions are available for installing the Audio Network Interface:

**CRT1 19" Rack Tray (optional accessory):** Supports up to 3 devices; mountable in a rack or under a table

**Single-unit Mounting Tray (included accessory):** Supports a single device for mounting under a table

## Securing the Devices

Use the included screws from the mounting hardware kit to secure the Audio Network Interfaces. Audio Network Interfaces can be mounted to face either direction. Insert the screws from the bottom in the appropriate holes, according to the following diagrams:

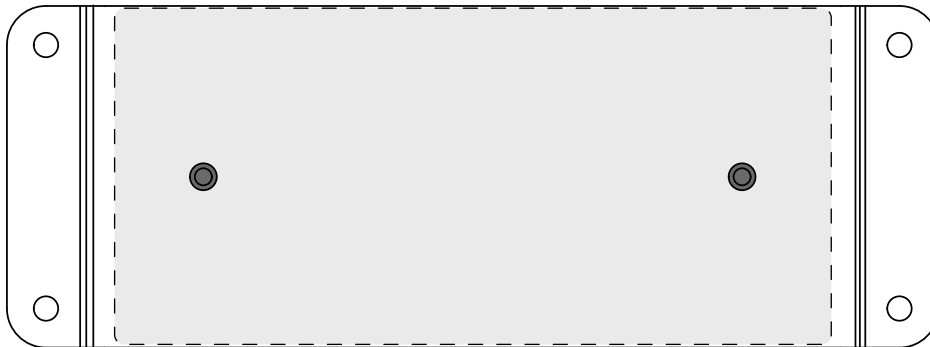

Align the holes as shown for securing a single device in the single-unit mounting tray

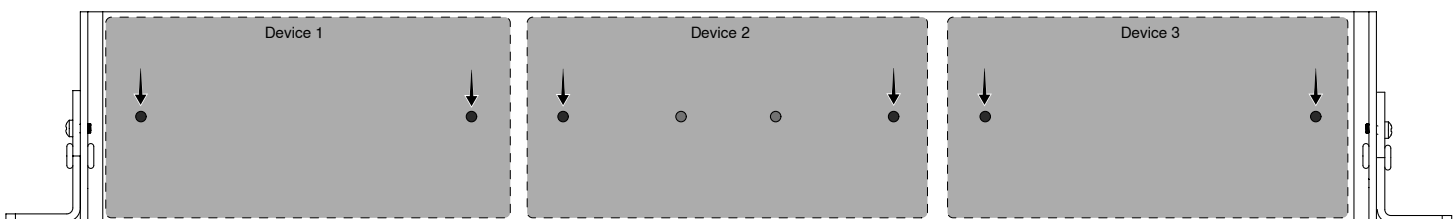

Align the holes as shown for securing up to three devices in the 19" rack tray.

### Rack Ear Configuration

A combination of up to 3 Audio Network Interfaces can be mounted in a single 19-inch rack space. The adjustable rack ears support mounting in a standard equipment rack or underneath a table.

### Standard 19" Rack Mount

1. Align the ears with the mounting holes pointed forward.
2. Install the two screws that hold the ear to the tray as shown.

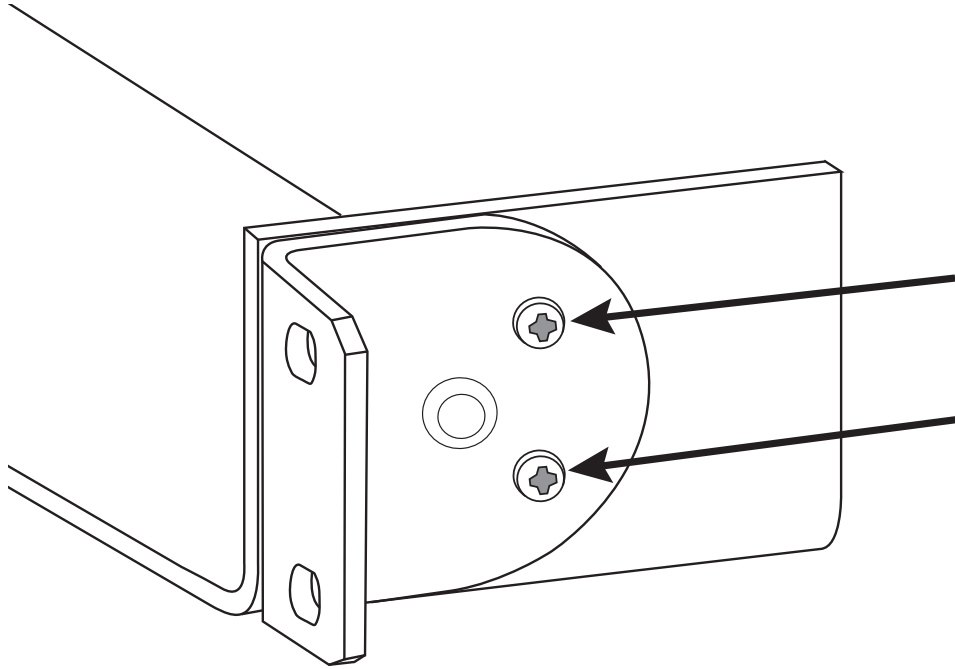

### Under-table Mounting

1. Align the ears with the mounting holes pointed upward.
2. Install the two screws that hold the ear to the tray as shown.

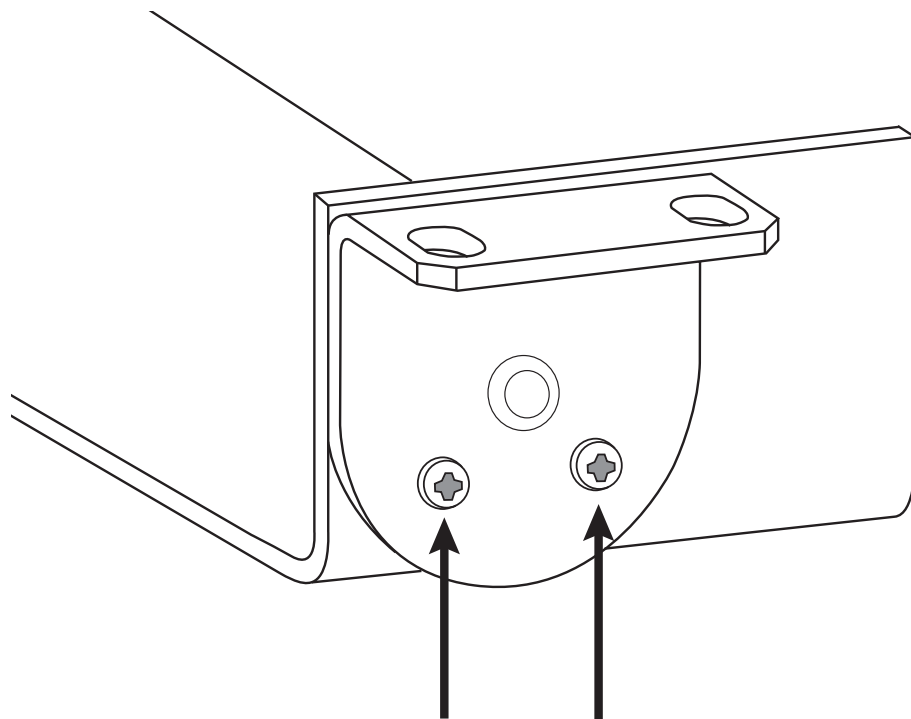

### Installing Underneath a Table

1. Hold the tray in the desired location under a table
2. Use a pencil to mark the location of the mounting holes on the table.
3. Drill 4 holes for the screws. The diameter of the holes in the tray are 7.1 mm.
4. Install the components into the tray
5. Install with 4 screws to secure the tray underneath the table



# Signal Flow and Connections

## Connections and Signal Flow

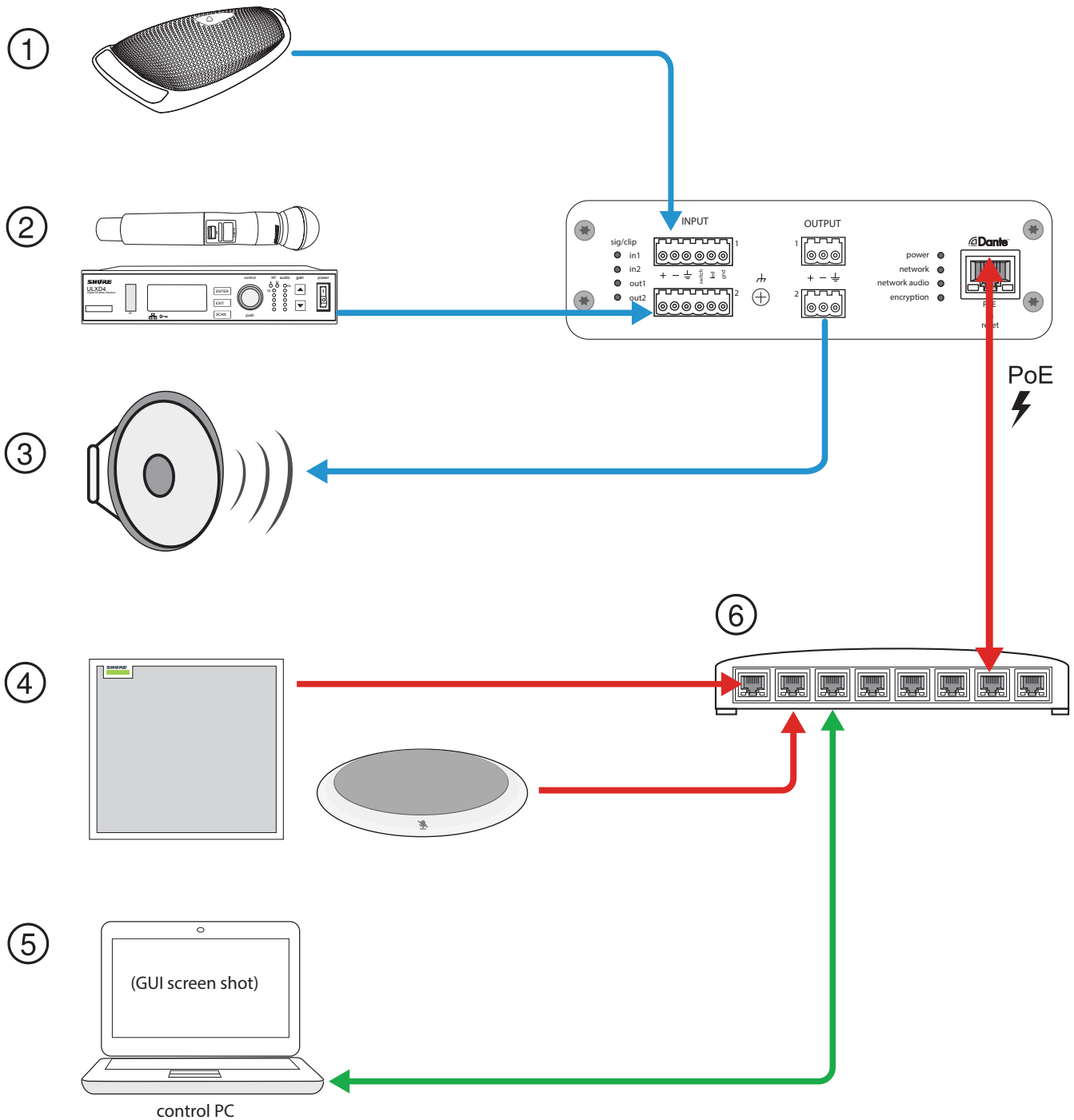

### ① Analog Input with Logic Connection (MX392)

In addition to running the audio signal, this boundary microphone features three additional wire leads for logic connections. This allows the switch on the microphone to send a logic mute signal to other equipment on the network, and to receive a logic LED control signal.

② **Analog Input Sources**

Analog sources, such as wireless microphones, connect to the analog line input

③ **Analog Output Devices**

Loudspeakers, amplifiers, or recording devices connect to the analog line output

④ **Dante-enabled Equipment**

Dante microphones, such as the Shure Microflex Advance ceiling and table arrays connect to the network switch and can be routed using Dante Controller software.

⑤ **Control CPU**

A computer connected to the network accesses the web application to control the channel levels and processing.

⑥ **Network Switch**

The network switch provides Power over Ethernet (PoE) to the ANI22, while also supporting all other Dante-enabled audio equipment.

**Summing**

The Audio Network Interface provides channel summing to combine input signals and send them over a single output channel. This makes it possible to send all channels to a device with a limited amount of Dante™ receiver channels or analog inputs. The relative channel levels are not affected; the mix is summed in the device and sent over a single output channel.

**Note:** When summing is enabled, a limiter is activated to prevent signal overloading. The limiter never applies to the direct outputs, and only affects the summed signal.

To enable, select one of the summing options in the toolbar at the top of the mixer in the channels tab.

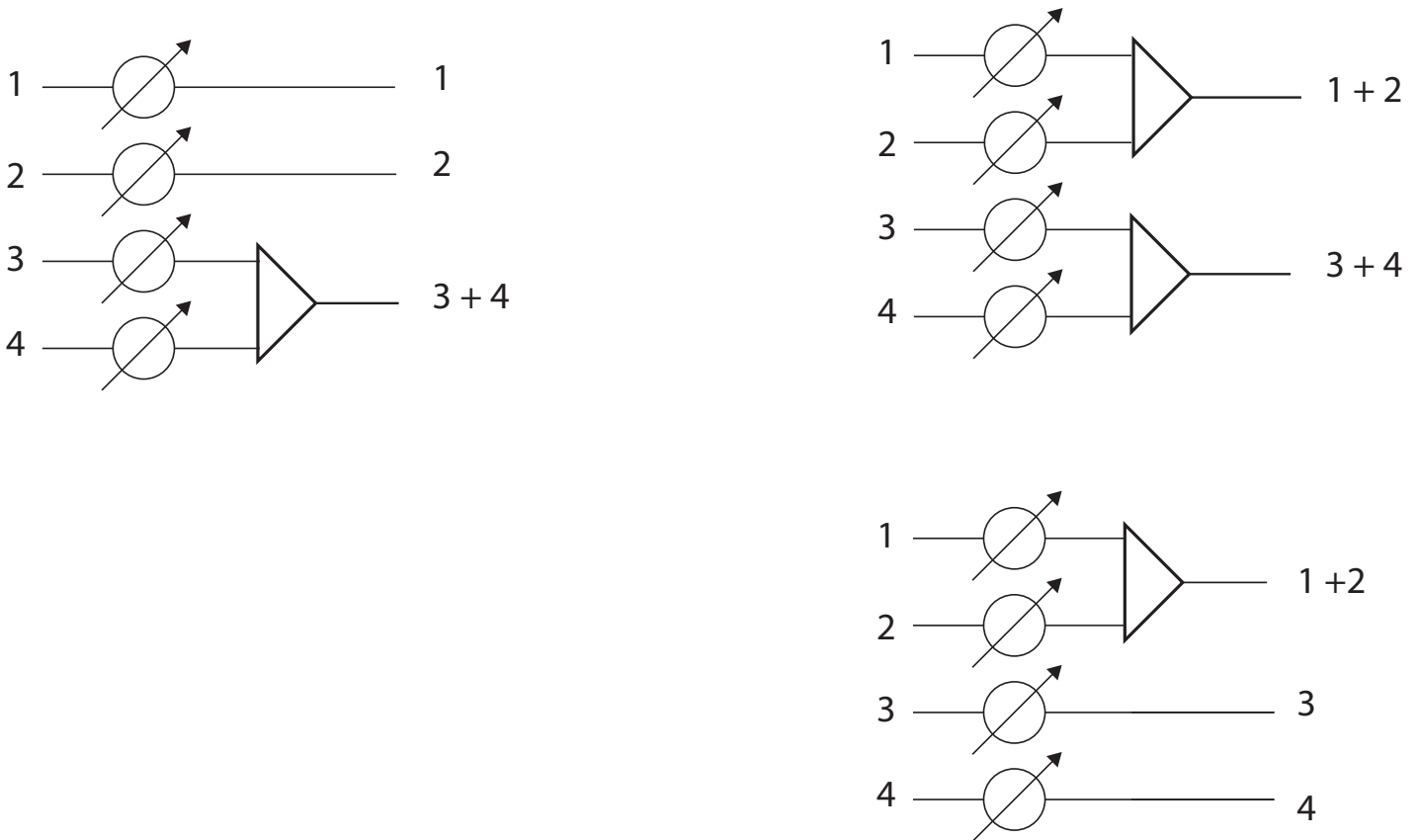

**Logic Applications**

The block connector inputs feature three logic signal connections. Logic signals are converted into Ethernet command strings and sent and received by any device (such as an echo canceller or control system) that supports Ethernet command strings.

In this diagram, Shure MX392 Microflex® microphones are connected the audio network interface. The mute button on each microphone sends a logic signal (switch) to mute other audio equipment. The microphones receive logic signals (LED) so that the microphone LED behavior reflects the state of the entire audio system.

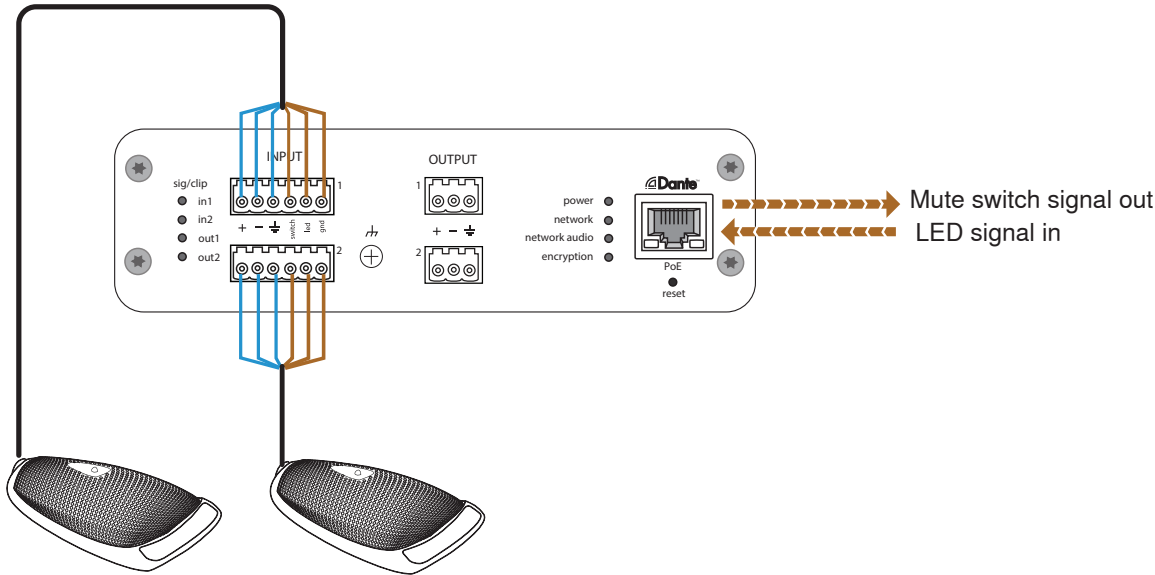

## Encryption

Audio is encrypted with the Advanced Encryption Standard (AES -256), as specified by the US Government National Institute of Standards and Technology (NIST) publication FIPS-197. Shure devices that support encryption require a passphrase to make a connection. Encryption is not supported with third-party devices.

To activate encryption:

1. Open the Settings menu and select the General tab.
2. Select the Enable Encryption checkbox.
3. Enter a passphrase. All devices must use the same passphrase to establish an encrypted connection.

**Important:** For encryption to work:

- Encryption must be universally enabled or disabled on all connected Shure devices
- AES67 must be disabled in Dante Controller to turn encryption on or off. AES67 encryption is currently not supported.

## Device Identification

Device Identify

To identify the hardware by flashing the lights, select the Identify button in the device options section.

## Using A Password

All settings are configurable by default. To protect settings with a password, open the Settings menu and select the General tab. In this screen, passwords can be created or changed.

Once a password has been set, a Read-Only option appears on the log-in screen. In Read-Only mode, device parameters can be viewed, but not edited. Device identification remains active.

## Audio Settings

### Adjusting Input levels

Input Levels

Levels for analog and Dante™ channels are adjustable in the Input tab.

### Dante™ Sources

1. Check the source level before it reaches the Network Interface:

- Verify that the networked microphones or other Dante™ sources are operating at nominal output levels.
  - Levels for Microflex Advance™ microphones are adjustable through their web application.
2. **Adjust the digital gain in the Network Interface web application:**
- Use the faders or manually enter a gain value.
  - The digital gain adjusts the level of the signal before it reaches the analog circuitry.
  - Set these levels as high as possible without reaching the peak level (0 dB) on the meter.

## Analog Sources

Before you begin, verify that levels from the analog devices with adjustable output levels are operating at nominal levels. The analog gain adjusts the level of the audio signal before it is converted from analog to digital. It is adjustable in 3 dB increments, with up to 51 dB total gain.

1. Match the analog gain setting to the incoming signal level:

Source Level	Gain Range
Line (+4 dBu)	0 to +9 dB
Auxiliary (-10 dBV)	+9 to +21 dB
Microphone (varies)	+21 to +51 dB

2. The meters should peak between -18 and -9 dB.

**Note:** Leaving some additional headroom is a recommended to prevent clipping if mobile devices will be plugged into particular channels.

## Adjusting Output Levels

Output Levels

### Dante Outputs

Output levels are controlled by the Digital Gain (dB) fader. Always adjust the input gain before the output gain. In most cases, setting the analog gain correctly results in an appropriate output level. Sources that have a quiet signal, such as a microphone with low sensitivity, may need some Digital Gain (dB) applied. If the output is clipping, use the Digital Gain (dB) fader to lower the signal.

**Note:** If summing is enabled on input channels, use the Digital Gain (dB) and Analog Gain (dB) controls in the Input section to adjust the mix.

### Analog Outputs

Match the output level from the Network Interface to the input sensitivity on the analog device:

- Line level (0 dB)
- Aux level (-20 dB)
- Microphone level (-46 dB)

### LED Signal and Clipping Indicators

Each analog output channel has a corresponding LED:

**Green:** Audio signal present

**Red:** Audio signal is clipping and should be attenuated.

## Metering Options (Pre-gain and Post-gain)

Metering

Each Dante channel includes a meter to measure signal levels (dBFS), located in the web application under the input and output sections.

**Pre-gain** metering measures the signal level without digital gain applied. It does reflect analog gain adjustments on the two input channels. **Post-gain** metering measures the signal with both analog and digital gain applied.

To change the metering setting, open the Settings menu, select the General tab, and adjust the Metering setting.

**Important:** If the incoming signal is adjustable (wireless microphone systems, for example), make sure it is at the nominal level before adjusting the analog gain on the Audio Network Interface.

## Parametric Equalizer

Maximize audio quality by adjusting the frequency response with the parametric equalizer.

Common equalizer applications:

- Improve speech intelligibility
- Reduce noise from HVAC systems or video projectors
- Reduce room irregularities
- Adjust frequency response for reinforcement systems

### Setting Filter Parameters

Adjust filter settings by manipulating the icons in the frequency response graph, or by entering numeric values. Disable a filter using the check-box next to the filter.

#### Filter Type

Only the first and last band have selectable filter types.

**Parametric:** Attenuates or boosts the signal within a customizable frequency range

**Low Cut:** Rolls off the audio signal below the selected frequency

**Low Shelf:** Attenuates or boosts the audio signal below the selected frequency

**High Cut:** Rolls off the audio signal above the selected frequency

**High Shelf:** Attenuates or boosts the audio signal above the selected frequency

#### Frequency

Select the center frequency of the filter to cut/boost

#### Gain

Adjusts the level for a specific filter (+/- 30 dB)

#### Q

Adjusts the range of frequencies affected by the filter. As this value increases, the bandwidth becomes thinner.

#### Width

Adjusts the range of frequencies affected by the filter. The value is represented in octaves.

**Note:** the Q and width parameters affect the equalization curve in the same way. The only difference is the way the values are represented.

Enable All   
 Select Channel Channel 1   
 Copy   
 Paste   
 Import from file   
 Export to file   
 Clear

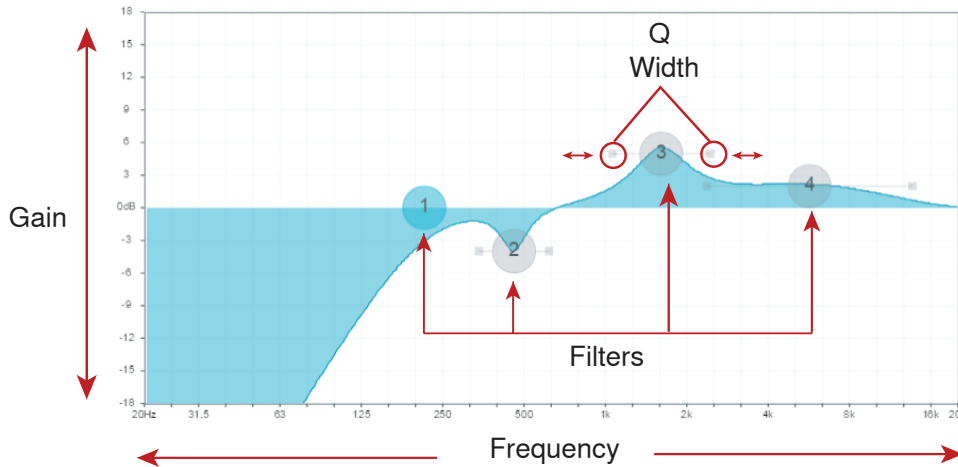

1	Filters	Frequency (Hz)	Gain (dB)	Q	Width (oct)
Channel 1	<input checked="" type="checkbox"/> Filter 1 <span>Low Cut</span>	217	N/A	N/A	N/A
	<input checked="" type="checkbox"/> Filter 2 <span>Parametric</span>	466	-4	4.32	1
	<input checked="" type="checkbox"/> Filter 3 <span>Parametric</span>	1634	5	2.14	1
	<input checked="" type="checkbox"/> Filter 4 <span>Parametric</span>	5786	2	0.67	1

## Copy, Paste, Import, and Export Equalizer Channel Settings

These features make it simple to use effective equalizer settings from a previous installation, or simply accelerate configuration time.

### Copy and Paste

Use to quickly apply the same PEQ setting across multiple channels.

1. Select the channel from the pull-down menu in the PEQ screen.
2. Select Copy
3. In the pull-down menu, select the channel to apply the PEQ setting and select Paste.

### Import and Export

Use to save and load PEQ settings from a file on a computer. This is useful for creating a library of reusable configuration files on computers used for system installation.

#### Export

Choose a channel to save the PEQ setting, and select Export to file.

#### Import

Choose a channel to load the PEQ setting, and select Import from file.

## Equalizer Applications

Conferencing room acoustics vary based on room size, shape, and construction materials. Use the guidelines in following table.

EQ Application	Suggested Settings
Treble boost for improved speech intelligibility	Add a high shelf filter to boost frequencies greater than 1 kHz by 3-6 dB
HVAC noise reduction	Add a low cut filter to attenuate frequencies below 200 Hz
Reduce flutter echoes and sibilance	<p>Identify the specific frequency range that "excites" the room: Set a narrow Q value</p> <p>Increase the gain to between +10 and +15 dB, and then experiment with frequencies between 1 kHz and 6 kHz to pinpoint the range of flutter echoes or sibilance</p> <p>Reduce the gain at the identified frequency (start between -3 and -6 dB) to minimize the unwanted room sound</p>
Reduce hollow, resonant room sound	<p>Identify the specific frequency range that "excites" the room: Set a narrow Q value</p> <p>Increase the gain to between +10 and +15 dB, and then experiment with frequencies between 300 Hz and 900 Hz to pinpoint the resonant frequency</p> <p>Reduce the gain at the identified frequency (start between -3 and -6 dB) to minimize the unwanted room sound</p>

## Custom Presets

Use presets to quickly save and recall settings. Up to 10 presets can be stored on each device to match various seating arrangements. A preset saves all device settings except for the Device Name, IP Settings, and Passwords. Importing and exporting presets into new installations saves time and improves workflow. When a preset is selected, the name displays above the preset menu. If changes are made, an asterisk appears next to the name.

**Note:** Use the default settings preset to revert to the factory configuration (excludes Device Name, IP Settings, and Passwords).

Open the presets menu to reveal preset options:

#### save as preset:

Saves settings to the device

#### load preset:

Opens a configuration from the device

#### import from file:

Downloads a preset file from a computer onto the device. Files may be selected through the browser or dragged into the import window.

#### export to file:

Saves a preset file from the device onto a computer

## Networking and Dante

### Dante™ Transmit Flows

#### Dante Flows

This device supports up to **two transmit flows** and **two receive flows**. A single flow consists of up to **four channels**, through either a unicast or multicast transmission.

- A **unicast flow** is a point-to-point connection between two devices, supporting up to four channels per flow.
- A **multicast flow** is a one-to-many transmission, which supports sending up to four channels to multiple receiving devices across the network.

### Shure Device Applications

This device can connect with up to two Dante devices.

The Shure MXA310, ANI22, ANIUSB-MATRIX and ANI4IN support multicast transmission. This means that flows can transmit to multiple devices -- as many as the network can support. If using unicast flows, each of these devices can connect with up to two Dante receiver devices.

The Shure ANI4OUT connects with up to two Dante transmitter devices.

### Pushing Device Names to the Dante Network

To send a device name to appear in Dante Controller, go to Settings>General and enter a Device Name. Select Push to Dante to send the name to appear on the network.

Note: names appear in Dante Controller with "-d" attached.

### QoS (Quality of Service) Settings

#### QoS Settings

QoS settings assign priorities to specific data packets on the network, ensuring reliable audio delivery on larger networks with heavy traffic. This feature is available on most managed network switches. Although not required, assigning QoS settings is recommended.

**Note:** Coordinate changes with the network administrator to avoid disrupting service.

To assign QoS values, open the switch interface and use the following table to assign Dante™ -associated queue values.

- Assign the highest possible value (shown as 4 in this example) for time-critical PTP events
- Use descending priority values for each remaining packet.

Table provided courtesy of Audinate®

Priority	Usage	DSCP Label	Hex	Decimal	Binary
High (4)	Time-critical PTP events	CS7	0x38	56	111000
Medium (3)	Audio, PTP	EF	0x2E	46	101110
Low (2)	(reserved)	CS1	0x08	8	001000
None (1)	Other traffic	BestEffort	0x00	0	000000

**Note:** Switch management may vary by manufacturer and switch type. Consult the manufacturer's product guide for specific configuration details.

For more information on Dante requirements and networking, visit [www.audinate.com](http://www.audinate.com).

### Networking Terminology

**PTP (Precision Time Protocol):** Used to synchronize clocks on the network

**DSCP (Differentiated Services Code Point):** Standardized identification method for data used in layer 3 QoS prioritization

## Event Log

#### Event Log

The event log provides a detailed account of activity from the moment the device is powered on. The log collects up to 1,000 activity entries and time-stamps them relative to the last power cycle. The entries are stored in the internal memory, and are not cleared when the device is power-cycled. The Export feature creates a CSV (comma separated values) document to save and sort the log data.

Refer to the log file for details when troubleshooting or consulting with Shure Systems Support.

#### To view the event log:

1. Open the Help menu
2. Select View Event Log

Severity Level

**Information**

An action or event has been successfully completed

**Warning**

An action cannot be complete, but overall functionality is stable

**Error**

A problem has occurred that could inhibit functionality.

Log Details

**Description**

Provides details on events and errors, including IP address and subnet mask.

**Time Stamp**

Power cycles:days:hours:minutes:seconds since most recent boot-up.

**Event ID**

Indicates event type for internal reference.

**Tip:** Use the filter to narrow down results. Select a category heading to sort the log.

## ANI22 Command Strings

This document can also be found at: [http://shure.custhelp.com/app/answers/detail/a\\_id/6368](http://shure.custhelp.com/app/answers/detail/a_id/6368)

The device is connected via Ethernet to a control system, such as AMX, Crestron or Extron.

**Connection:** Ethernet (TCP/IP; select "Client" in the AMX/Crestron program)

**Port:** 2202

### Conventions

The device has 4 types of strings:

**GET**

Finds the status of a parameter. After the AMX/Crestron sends a GET command, the ANI22 responds with a REPORT string

**SET**

Changes the status of a parameter. After the AMX/Crestron sends a SET command, the ANI22 will respond with a REPORT string to indicate the new value of the parameter.

**REP**

When the ANI22 receives a GET or SET command, it will reply with a REPORT command to indicate the status of the parameter. REPORT is also sent by the ANI22 when a parameter is changed on the ANI22 or through the GUI.

**SAMPLE**

Used for metering audio levels.

All messages sent and received are ASCII. Note that the level indicators and gain indicators are also in ASCII

Most parameters will send a REPORT command when they change. Thus, it is not necessary to constantly query parameters. The ANI22 will send a REPORT command when any of these parameters change.

The character "x" in all of the following strings represents the channel of the ANI22 and can be ASCII numbers 0 through 4 as in the following table

00	All channels
01, 02	Analog Inputs
03, 04	Analog Outputs

### Command Strings (Common)

Get All	
Command String: < GET xx ALL >	Where xx is ASCII channel number: 00 through 04. Use this command on first power on to update the status of all parameters.
ANI22 Response: < REP ... >	The ANI22 responds with individual Report strings for all parameters.
Get Model Number	
Command String: < GET MODEL >	
ANI22 Response: < REP MODEL {yyyyyyyyyyyyyyyyyyyyyyyyyyyyyyyy} >	Where yyyyyyyyyyyyyyyyyyyyyyyyyyyyyyyyy is 32 characters of the model number. The ANI22 always responds with a 32 character model number.
Get Serial Number	
Command String: < GET SERIAL_NUM >	



<p>ANI22 Response:                  &lt; REP SERIAL_NUM {yyyyyyyyyyyyyyyyyyyyyyyyyyyyyyyy} &gt;</p>	<p>Where yyyyyyyyyyyyyyyyyyyyyyyyyyyyyyyyy is 32 characters of the serial number. The ANI22 always responds with a 32 character serial number.</p>
<b>Get Channel Name</b>	
<p>Command String:                  &lt; GET xx CHAN_NAME</p>	<p>Where xx is ASCII channel number: 00 through 04.</p>
<p>ANI22 Response:                  &lt; REP xx CHAN_NAME {yyyyyyyyyyyyyyyyyyyyyyyyyyyyyy} &gt;</p>	<p>Where yyyyyyyyyyyyyyyyyyyyyyyyyyyyyyy is 31 characters of the user name. The ANI22 always responds with a 31 character name.</p>
<b>Get Device ID</b>	
<p>Command String:                  &lt; GET DEVICE_ID &gt;</p>	<p>The Device ID command does not contain the x channel character, as it is for the entire ANI22.</p>
<p>ANI22 Response:                  &lt; REP DEVICE_ID {yyyyyyyyyyyyyyyyyyyyyyyyyyyyyy} &gt;</p>	<p>Where yyyyyyyyyyyyyyyyyyyyyyyyyyyyyyy is 31 characters of the device ID. The ANI22 always responds with a 31 character device ID.</p>
<b>Get Firmware Version</b>	
<p>Command String:                  &lt; GET FW_VER &gt;</p>	
<p>ANI22 Response:                  &lt; REP FW_VER {yyyyyyyyyyyyyyyyyyyy} &gt;</p>	<p>Where yyyyyyyyyyyyyyyyy is 18 characters. The ANI22 always responds with 18 characters.</p>
<b>Get Preset</b>	
<p>Command String:                  &lt; GET PRESET &gt;</p>	
<p>ANI22 Response:                  &lt; REP PRESET nn &gt;</p>	<p>Where nn is the preset number 01-10.</p>
<b>Set Preset</b>	
<p>Command String:                  &lt; SET PRESET nn &gt;</p>	<p>Where nn is the preset number 1-10. (Leading zero is optional when using the SET command).</p>
<p>ANI22 Response:                  &lt; REP PRESET nn &gt;</p>	<p>Where nn is the preset number 01-10.</p>
<b>Get Preset Name</b>	
<p>Command String:                  &lt; GET PRESET1 &gt;                  &lt; GET PRESET2 &gt;                  &lt; GET PRESET3 &gt;                  etc</p>	<p>Send one of these commands to the ANI22</p>
<p>ANI22 Response:                  &lt; REP PRESET1 {yyyyyyyyyyyyyyyyyyyyyyyyyy} &gt;                  &lt; REP PRESET2 {yyyyyyyyyyyyyyyyyyyyyyyyyy} &gt;                  &lt; REP PRESET3 {yyyyyyyyyyyyyyyyyyyyyyyyyy} &gt;                  etc</p>	<p>Where yyyyyyyyyyyyyyyyyyyyyyyyyyy is 25 characters of the device ID. The ANI22 always responds with a 25 character device ID</p>
<b>Get Audio Gain</b>	
<p>Command String:                  &lt; GET xx AUDIO_GAIN_HI_RES &gt;</p>	<p>Where xx is ASCII channel number: 01 through 04.</p>
<p>ANI22 Response:                  &lt; REP xx AUDIO_GAIN_HI_RES yyyy &gt;</p>	<p>Where yyyy takes on the ASCII values of 0000 to 1400. yyyy is in steps of one-tenth of a dB.</p>
<b>Set Audio Gain</b>	
<p>Command String:                  &lt; SET xx AUDIO_GAIN_HI_RES yyyy &gt;</p>	<p>Where yyyy takes on the ASCII values of 0000 to 1400. yyyy is in steps of one-tenth of a dB.</p>

	<p>ANI22 Response: &lt; REP xx AUDIO_GAIN_HI_RES yyyy &gt;</p>	Where yyyy takes on the ASCII values of 0000 to 1400.
<b>Increase Audio Gain by n dB</b>		
	<p>Command String: &lt; SET xx AUDIO_GAIN_HI_RES INC nn &gt;</p>	Where nn is the amount in one-tenth of a dB to increase the gain. nn can be single digit ( n ), double digit ( nn ), triple digit ( nnn ).
	<p>ANI22 Response: &lt; REP xx AUDIO_GAIN_HI_RES yyyy &gt;</p>	Where yyyy takes on the ASCII values of 0000 to 1400.
<b>Decrease Audio Gain by n dB</b>		
	<p>Command String: &lt; SET xx AUDIO_GAIN_HI_RES DEC nn &gt;</p>	Where nn is the amount in one-tenth of a dB to decrease the gain. nn can be single digit ( n ), double digit ( nn ), triple digit ( nnn ).
	<p>ANI22 Response: &lt; REP xx AUDIO_GAIN_HI_RES yyyy &gt;</p>	Where yyyy takes on the ASCII values of 0000 to 1400.
<b>Get Analog Audio Gain - Input</b>		
	<p>Command String: &lt; GET xx AUDIO_GAIN &gt;</p>	Where xx is ASCII channel number: 00 through 02.
	<p>ANI22 Response: &lt; REP xx AUDIO_GAIN yy &gt;</p>	Where yy takes on the ASCII values of 00 to 51. yy is in 3 dB steps.
<b>Set Analog Audio Gain - Input</b>		
	<p>Command String: &lt; SET xx AUDIO_GAIN yy &gt;</p>	Where xx is ASCII channel number: 00 through 02.
	<p>ANI22 Response: &lt; REP xx AUDIO_GAIN yy &gt;</p>	Where yy takes on the ASCII values of 00 to 51. yy is in 3 dB steps.
<b>Increment Analog Audio Gain - Input</b>		
	<p>Command String: &lt; GET xx AUDIO_GAIN INC n &gt;</p>	Where n is the amount in dB to increase the gain, in 3dB steps.
	<p>ANI22 Response: &lt; REP xx AUDIO_GAIN yy &gt;</p>	Where yy takes on the ASCII values of 00 to 51. yy is in 3 dB steps.
<b>Decrement Analog Audio Gain - Input</b>		
	<p>Command String: &lt; GET xx AUDIO_GAIN DEC n &gt;</p>	Where n is the amount in dB to increase the gain, in 3dB steps.
	<p>ANI22 Response: &lt; REP xx AUDIO_GAIN yy &gt;</p>	Where yy takes on the ASCII values of 00 to 51. yy is in 3 dB steps.
<b>Get Channel Audio Mute</b>		
	<p>Command String: &lt; GET xx AUDIO_MUTE &gt;</p>	Where x is ASCII channel number: 00 through 04.
	<p>ANI22 Response: &lt; REP xx AUDIO_MUTE ON &gt; &lt; REP xx AUDIO_MUTE OFF &gt;</p>	The ANI22 will respond with one of these strings.
<b>Mute Channel Audio</b>		
	<p>Command String: &lt; SET xx AUDIO_MUTE ON &gt;</p>	
	<p>ANI22 Response: &lt; REP xx AUDIO_MUTE ON &gt;</p>	
<b>Unmute Channel Audio</b>		

	<p>Command String:</p> <p>&lt; SET xx AUDIO_MUTE OFF &gt;</p>	
	<p>ANI22 Response:</p> <p>&lt; REP xx AUDIO_MUTE OFF &gt;</p>	
<b>Toggle Channel Audio Mute</b>		
	<p>Command String:</p> <p>&lt; SET xx AUDIO_MUTE TOGGLE &gt;</p>	
	<p>ANI22 Response:</p> <p>&lt; REP xx AUDIO_MUTE ON &gt;</p> <p>&lt; REP xx AUDIO_MUTE OFF &gt;</p>	The ANI22 will respond with one of these strings.
<b>Get Device Audio Mute</b>		
	<p>Command String:</p> <p>&lt; GET DEVICE_AUDIO_MUTE &gt;</p>	
	<p>ANI22 Response:</p> <p>&lt; REP DEVICE_AUDIO_MUTE ON &gt;</p> <p>&lt; REP DEVICE_AUDIO_MUTE OFF &gt;</p>	The ANI22 will respond with one of these strings.
<b>Set Device Audio Mute</b>		
	<p>Command String:</p> <p>&lt; SET DEVICE_AUDIO_MUTE ON &gt;</p> <p>&lt; SET DEVICE_AUDIO_MUTE OFF &gt;</p> <p>&lt; SET DEVICE_AUDIO_MUTE TOGGLE &gt;</p>	Send one of these commands to the ANI22.
	<p>ANI22 Response:</p> <p>&lt; REP DEVICE_AUDIO_MUTE ON &gt;</p> <p>&lt; REP DEVICE_AUDIO_MUTE OFF &gt;</p>	The ANI22 will respond with one of these strings.
<b>Get Analog Output Gain Switch</b>		
	<p>Command String:</p> <p>&lt; GET xx AUDIO_OUT_LVL_SWITCH &gt;</p>	Where xx is ASCII channel number: 00, 03, or 04.
	<p>ANI22 Response:</p> <p>&lt; REP xx AUDIO_OUT_LVL_SWITCH LINE_LVL &gt;</p> <p>&lt; REP xx AUDIO_OUT_LVL_SWITCH AUX_LVL &gt;</p> <p>&lt; REP xx AUDIO_OUT_LVL_SWITCH MIC_LVL &gt;</p>	The ANI22 will respond with one of these strings.
<b>Set Analog Output Gain Switch</b>		
	<p>Command String:</p> <p>&lt; SET xx AUDIO_OUT_LVL_SWITCH LINE_LVL &gt;</p> <p>&lt; SET xx AUDIO_OUT_LVL_SWITCH AUX_LVL &gt;</p> <p>&lt; SET xx AUDIO_OUT_LVL_SWITCH MIC_LVL &gt;</p>	Where xx is ASCII channel number: 00, 03, or 04. Send one of these commands to the ANI22.
	<p>ANI22 Response:</p> <p>&lt; REP xx AUDIO_OUT_LVL_SWITCH LINE_LVL &gt;</p> <p>&lt; REP xx AUDIO_OUT_LVL_SWITCH AUX_LVL &gt;</p> <p>&lt; REP xx AUDIO_OUT_LVL_SWITCH MIC_LVL &gt;</p>	The ANI22 will respond with one of these strings.
<b>Flash Lights on ANI22</b>		
	<p>Command String:</p> <p>&lt; SET FLASH ON &gt;</p> <p>&lt; SET FLASH OFF &gt;</p>	Send one of these commands to the ANI22. The flash automatically turns off after 30 seconds.
	<p>ANI22 Response:</p> <p>&lt; REP FLASH ON &gt;</p> <p>&lt; REP FLASH OFF &gt;</p>	The ANI22 will respond with one of these strings.
<b>Turn Metering On</b>		

<p>Command String: &lt; SET METER_RATE sssss &gt;</p>	<p>Where sssss is the metering speed in milliseconds. Setting sssss=0 turns metering off. Minimum setting is 100 milliseconds. Metering is off by default.</p>
<p>ANI22 Response: &lt; REP METER_RATE sssss &gt; &lt; SAMPLE aaa bbb ccc ddd &gt;</p>	<p>Where aaa, bbb, etc is the value of the audio level received and is 000-060. aaa = input 1 bbb = input 2 ccc = output 1 ddd = output 2</p>
<b>Stop Metering</b>	
<p>Command String: &lt; SET METER_RATE 0 &gt;</p>	<p>A value of 00000 is also acceptable.</p>
<p>ANI22 Response: &lt; REP METER_RATE 00000 &gt;</p>	
<b>Get LED Brightness</b>	
<p>Command String: &lt; GET LED_BRIGHTNESS &gt;</p>	
<p>ANI22 Response: &lt; REP LED_BRIGHTNESS n &gt;</p>	<p>Where n can take on the following values: 0 = LED disabled 1 = LED dim 2 = LED default</p>
<b>Set LED Brightness</b>	
<p>Command String: &lt; SET LED_BRIGHTNESS n &gt;</p>	<p>Where n can take on the following values: 0 = LED disabled 1 = LED dim 2 = LED default</p>
<p>ANI22 Response: &lt; REP LED_BRIGHTNESS n &gt;</p>	
<b>Get Audio Clip Indicator</b>	
<p>Command String: &lt; GET xx AUDIO_OUT_CLIP_INDICATOR &gt;</p>	<p>Where xx is ASCII channel number: 00 through 04.</p>
<p>ANI22 Response: &lt; REP xx AUDIO_OUT_CLIP_INDICATOR ON &gt; &lt; REP xx AUDIO_OUT_CLIP_INDICATOR OFF &gt;</p>	<p>The ANI22 will respond with one of these strings.</p>
<b>Get Audio IP Address</b>	
<p>Command String: &lt; GET IP_ADDR_NET_AUDIO_PRIMARY &gt;</p>	
<p>ANI22 Response: &lt; REP IP_ADDR_NET_AUDIO_PRIMARY {yyyyyyyyyyyyyyyy} &gt;</p>	<p>Where yyyyyyyyyyyyyyy is a 15 digit IP address.</p>
<b>Get Audio Subnet Address</b>	
<p>Command String: &lt; GET IP_SUBNET_NET_AUDIO_PRIMARY &gt;</p>	
<p>ANI22 Response: &lt; REP IP_SUBNET_NET_AUDIO_PRIMARY {yyyyyyyyyyyyyyyy} &gt;</p>	<p>Where yyyyyyyyyyyyyyy is a 15 digit subnet address.</p>
<b>Get Audio Gateway Address</b>	
<p>Command String: &lt; GET IP_GATEWAY_NET_AUDIO_PRIMARY &gt;</p>	
<p>ANI22 Response: &lt; REP IP_GATEWAY_NET_AUDIO_PRIMARY {yyyyyyyyyyyyyyyy} &gt;</p>	<p>Where yyyyyyyyyyyyyyy is a 15 digit gateway address.</p>

<b>Get Limiter Status</b>		
	Command String: < GET LIMITER_ENGAGED >	Indicates if the limiter is currently reducing the signal level.
	ANI22 Response: < REP LIMITER_ENGAGED ON > < REP LIMITER_ENGAGED OFF >	The ANI22 will respond with one of these strings.
<b>Get Encryption Status</b>		
	Command String: < GET xx ENCRYPTION_CH >	
	ANI22 Response: < REP xx ENCRYPTION_CH ON > < REP xx ENCRYPTION_CH OFF >	The ANI22 will respond with one of these strings.
<b>Get Phantom Power Status</b>		
	Command String: < GET xx PHANTOM_PWR_ENABLE >	
	ANI22 Response: < REP xx PHANTOM_PWR_ENABLE ON > < REP xx PHANTOM_PWR_ENABLE OFF >	The ANI22 will respond with one of these strings.
<b>Turn Phantom Power On/Off</b>		
	Command String: < SET xx PHANTOM_PWR_ENABLE ON > < SET xx PHANTOM_PWR_ENABLE OFF >	Send one of these commands to the ANI22.
	ANI22 Response: < REP xx PHANTOM_PWR_ENABLE ON > < REP xx PHANTOM_PWR_ENABLE OFF >	The ANI22 will respond with one of these strings.
<b>Reboot ANI22</b>		
	Command String: < SET REBOOT >	
	ANI22 Response: < REP REBOOT >	
<b>Get Error Events</b>		
	Command String: < GET LAST_ERROR_EVENT >	Gets the last error that is logged on the ANI22.
	ANI22 Response: < REP LAST_ERROR_EVENT {yyyyyyyyyyyyyyyy} >	Where yyyyyyyyyyyyyyy is up to 128 characters.
<b>Get PEQ Filter Enable</b>		
	Command String: < GET xx PEQ yy >	Where xx is the PEQ block 01-04. Where yy is the PEQ filter 01-04 within the block. 00 can be used for all blocks or all filters.
	ANI22 Response: < REP xx PEQ yy ON > < REP xx PEQ yy OFF >	
<b>Set PEQ Filter Enable</b>		
	Command String: < SET xx PEQ yy ON > < SET xx PEQ yy OFF >	Send one of these commands to the ANI22.

	<p>ANI22 Response:</p> <p>&lt; REP xx PEQ yy ON &gt;</p> <p>&lt; REP xx PEQ yy OFF &gt;</p>	Where xx is the PEQ block 01-04. Where yy is the PEQ filter 01-04 within the block. 00 can be used for all blocks or all filters.
<b>Get Audio Summing Mode</b>		
	<p>Command String:</p> <p>&lt; GET AUDIO_SUMMING_MODE &gt;</p>	
	<p>ANI22 Response:</p> <p>&lt; REP AUDIO_SUMMING_MODE OFF &gt;</p> <p>&lt; REP AUDIO_SUMMING_MODE 1+2 &gt;</p> <p>&lt; REP AUDIO_SUMMING_MODE 3+4 &gt;</p> <p>&lt; REP AUDIO_SUMMING_MODE 1+2/3+4 &gt;</p>	The ANI22 will respond with one of these strings.
<b>Set Audio Summing Mode</b>		
	<p>Command String:</p> <p>&lt; SET AUDIO_SUMMING_MODE OFF &gt;</p> <p>&lt; SET AUDIO_SUMMING_MODE 1+2 &gt;</p> <p>&lt; SET AUDIO_SUMMING_MODE 3+4 &gt;</p> <p>&lt; SET AUDIO_SUMMING_MODE 1+2/3+4 &gt;</p>	Send one of these commands to the ANI22.
	<p>ANI22 Response:</p> <p>&lt; REP AUDIO_SUMMING_MODE OFF &gt;</p> <p>&lt; REP AUDIO_SUMMING_MODE 1+2 &gt;</p> <p>&lt; REP AUDIO_SUMMING_MODE 3+4 &gt;</p> <p>&lt; REP AUDIO_SUMMING_MODE 1+2/3+4 &gt;</p>	The ANI22 will respond with one of these strings.
<b>Get Mic Logic Switch Out</b>		
	<p>Command String:</p> <p>&lt; GET HW_GATING_LOGIC &gt;</p>	
	<p>ANI22 Response:</p> <p>&lt; REP HW_GATING_LOGIC ON &gt;</p> <p>&lt; REP HW_GATING_LOGIC OFF &gt;</p>	The ANI22 will respond with one of these strings.
<b>Get Mic Logic LED In</b>		
	<p>Command String:</p> <p>&lt; GET CHAN_LED_IN_STATE &gt;</p>	
	<p>ANI22 Response:</p> <p>&lt; REP CHAN_LED_IN_STATE ON &gt;</p> <p>&lt; REP CHAN_LED_IN_STATE OFF &gt;</p>	The ANI22 will respond with one of these strings.
<b>Set Mic Logic LED In</b>		
	<p>Command String:</p> <p>&lt; SET CHAN_LED_IN_STATE ON &gt;</p> <p>&lt; SET CHAN_LED_IN_STATE OFF &gt;</p>	Send one of these commands to the ANI22.
	<p>ANI22 Response:</p> <p>&lt; REP CHAN_LED_IN_STATE ON &gt;</p> <p>&lt; REP CHAN_LED_IN_STATE OFF &gt;</p>	The ANI22 will respond with one of these strings.
<b>Get Input Meter Display Mode</b>		
	<p>Command String:</p> <p>&lt; GET INPUT_METER_MODE &gt;</p>	
	<p>ANI22 Response:</p> <p>&lt; REP INPUT_METER_MODE PRE_FADER &gt;</p> <p>&lt; REP INPUT_METER_MODE POST_FADER &gt;</p>	The ANI22 will respond with one of these strings.
<b>Set Input Meter Display Mode</b>		

<b>Command String:</b> < SET INPUT_METER_MODE PRE_FADER > < SET INPUT_METER_MODE POST_FADER >	Send one of these commands to the ANI22.
<b>ANI22 Response:</b> < REP INPUT_METER_MODE PRE_FADER > < REP INPUT_METER_MODE POST_FADER >	The ANI22 will respond with one of these strings.

## Important Product Information

The equipment is intended to be used in professional audio applications.

**Note:** This device is not intended to be connected directly to a public internet network.

EMC conformance to Environment E2: Commercial and Light Industrial. Testing is based on the use of supplied and recommended cable types. The use of other than shielded (screened) cable types may degrade EMC performance.

Changes or modifications not expressly approved by Shure Incorporated could void your authority to operate this equipment.

**Industry Canada ICES-003 Compliance Label:** CAN ICES-3 (B)/NMB-3(B)

Please follow your regional recycling scheme for batteries, packaging, and electronic waste.

### Information to the user

This equipment has been tested and found to comply with the limits for a Class B digital device, pursuant to Part 15 of the FCC Rules. These limits are designed to provide reasonable protection against harmful interference in a residential installation. This equipment generates uses and can radiate radio frequency energy and, if not installed and used in accordance with the instructions, may cause harmful interference to radio communications. However, there is no guarantee that interference will not occur in a particular installation. If this equipment does cause harmful interference to radio or television reception, which can be determined by turning the equipment off and on, the user is encouraged to try to correct the interference by one or more of the following measures:

- Reorient or relocate the receiving antenna.
- Increase the separation between the equipment and the receiver.
- Connect the equipment to an outlet on a circuit different from that to which the receiver is connected.
- Consult the dealer or an experienced radio/TV technician for help.

Authorized under the verification provision of FCC Part 15B.

The CE Declaration of Conformity can be obtained from:  
[www.shure.com/europe/compliance](http://www.shure.com/europe/compliance)

Authorized European representative:  
 Shure Europe GmbH  
 Headquarters Europe, Middle East & Africa  
 Department: EMEA Approval  
 Jakob-Dieffenbacher-Str. 12  
 75031 Eppingen, Germany  
 Phone: +49-7262-92 49 0  
 Fax: +49-7262-92 49 11 4  
 Email: [info@shure.de](mailto:info@shure.de)

This product meets the Essential Requirements of all relevant European directives and is eligible for CE marking.

The CE Declaration of Conformity can be obtained from Shure Incorporated or any of its European representatives. For contact information please visit [www.shure.com](http://www.shure.com)

## Specifications

### Analog Connections

Inputs	Active Balanced	ANI22-XLR	(2) XLR connector
		ANI22-BLOCK	(2) 6-pin block connector
Outputs	Impedance Balanced	ANI22-XLR	(2) XLR connector
		ANI22-BLOCK	(2) 3-pin block connector

### Network Connections (Dante Digital Audio)

(1) RJ45

Channel Count: 2 Inputs, 2 Outputs

### Polarity

Non-inverting, any input to any output

### Power Requirements

Power over Ethernet (PoE), Class 0. (PoE Plus compatible).

### Power Consumption

11W, maximum

### Weight

672 g (1.5 lbs)

### Dimensions

H x W x D

4 x 14 x 12.8 cm (1.6 x 5.5 x 5.0 in.)

### control application

HTML5 Browser-based

### Operating Temperature Range

-6.7°C (20°F) to 40°C (104°F)

### Storage Temperature Range

-29°C (-20°F) to 74°C (165°F)

**Thermal Power Dissipation**

Maximum	12.1 W (41.3 BTU/hr)
typical	9.8 W (33.7 BTU/hr)

**Audio****Frequency Response**

±1 dB

20 to 20,000 Hz

**Dante Digital Audio**

Sampling Rate	48 kHz
Bit Depth	24

**Latency**

Does not include Dante latency	Analog to Dante	0.35 ms
	Dante to Analog	0.71 ms

**analog gain range**

Adjustable in 3 dB steps

51 dB

**Dynamic Range (Analog-to-Dante)**

20 Hz to 20 kHz, A-weighted, typical

113 dB

**Equivalent Input Noise**

20 Hz to 20 kHz, A-weighted, input terminated with 150Ω

Analog Gain Setting= +0 dB	-93 dBV
Analog Gain Setting= +27 dB	-119 dBV
Analog Gain Setting= +51 dB	-130 dBV

**Total Harmonic Distortion**

@ 1 kHz, 0 dBV Input, 0 dB analog gain

&lt;0.05%

**Common Mode Rejection Ratio**

150Ω balanced source @ 1 kHz

&gt;70 dB

**Input Impedance**

5 kΩ

**Output Impedance**

150 Ω

**Input Clipping Level**

Analog Gain Setting= +0 dB	+20 dBV
Analog Gain Setting= +27 dB	-7 dBV
Analog Gain Setting= +51 dB	-31 dBV

**Analog Output Level**

Selectable	Line	0 dB
	Aux	-20 dB
	Mic	-46 dB

**Built-in Digital Signal Processing**

Per Channel	Equalizer (4-band Parametric, Dante Channels Only), Mute, Limiter, Gain (140 dB range)
System	Channel Summing

**Networking****Cable Requirements**

Cat 5e or higher (shielded cable recommended)

**Accessories****Furnished Accessories**

Hardware kit (XLR model)	90A29254
Hardware kit (block connector model)	90B33522
Mounting Bracket (1/3 rack unit)	53A27742

**Optional Accessories and Replacement Parts**

19" rack tray	CRT1
---------------	------