



# SPEAKER SYSTEM

H-1

Please follow the instructions in this manual to obtain the optimum results from this unit. We also recommend that you keep this manual handy for future reference.

## TABLE OF CONTENTS

1. SAFETY PRECAUTIONS .....	2
2. GENERAL DESCRIPTION .....	3
3. FEATURES .....	3
4. HANDLING PRECAUTIONS .....	3
5. NOMENCLATURE .....	4
6. INSTALLATION	
6.1. Direct Wall/Ceiling Mounting Without Using an Electrical Box .....	5
6.2. Mounting the Speaker to an Electrical Box Using The Adapter Frame .....	8
6.3. Mounting the Speaker Directly to an Electrical Box .....	9
6.4. Removing the Trim Piece .....	9
7. REPAINTING THE GRILLE AND TRIM PIECE .....	10
8. PROTECTION CIRCUITRY INFORMATION .....	11
9. EQUALIZATION .....	12
10. SPECIFICATIONS .....	12
Accessories .....	12

# 1. SAFETY PRECAUTIONS

- Be sure to read the instructions in this section carefully before use.
- Make sure to observe the instructions in this manual as the conventions of safety symbols and messages regarded as very important precautions are included.
- We also recommend you keep this instruction manual handy for future reference.

## Safety Symbol and Message Conventions

Safety symbols and messages described below are used in this manual to prevent bodily injury and property damage which could result from mishandling. Before operating your product, read this manual first so you are thoroughly aware of the potential safety hazards as well as understand the safety symbols and messages.



### **WARNING**

Indicates a potentially hazardous situation which, if mishandled, could result in death or serious personal injury.



### **CAUTION**

Indicates a potentially hazardous situation which, if mishandled, could result in moderate or minor personal injury, and/or property damage.



### **WARNING**

#### ■ When Installing the Unit

- Install the unit only in a location that can structurally support the weight of the unit and the mounting bracket. Doing otherwise may result in the speaker falling down and causing personal injury and/or property damage.

#### ■ When the Unit is in Use

- Should the following irregularity be found during use, immediately stop operating the unit and contact your nearest TOA dealer. Make no further attempt to operate the unit in this condition as this may cause fire or electric shock.
  - If you detect smoke or a strange smell coming from the unit.
  - If water or any metallic object gets into the unit.
  - If it is malfunctioning (no tone sounds.)



### **CAUTION**

#### ■ When the Unit is in Use

- Do not operate the speaker for an extended period of time with the sound distorting. This is an indication of a malfunction, which in turn can cause heat to generate and result in a fire.

## **2. GENERAL DESCRIPTION**

TOA's H-1 is a cylinder-shaped, small flush-mount 2-way speaker featuring high sound quality.

## **3. FEATURES**

- The H-1 Speaker System features, flush-mount speaker design with a rotatable cylinder-type enclosure. The speaker's smooth curved surface allows it to blend in with the interiors of most modern buildings.
- The speaker's small (8x5 cm) woofer features a magnetic circuit (employing a neodymium magnet) that ensures powerful sound reproduction.
- The one-inch balanced dome tweeter features ferro-fluid to ensure superb transient response characteristics for clear, high frequency sound output and high power-handling capabilities.
- The speaker's built-in crossover network circuitry features sharp cut-off characteristics that realize uniform energy radiation while suppressing unwanted input signals to the woofer or tweeter.
- The H-1 Speaker System is designed with an emphasis on installation ease and safety, as well as easier conduit wiring when an electrical box is installed.
- The cylinder-shaped speaker's mounting angle can be easily adjusted for up to  $\pm 45$  degrees rotation.
- A built-in matching transformer permits the speaker to be used for both high- and low-impedance applications. For low-impedance applications, either the 4  $\Omega$  or 16  $\Omega$  terminal can be selected. Impedance can be easily changed from outside the unit.
- Detachable screw terminals facilitate connection. Dual positive and negative terminals also facilitate bridge connections.
- Both the speaker enclosure and Trim Piece are made of fire-resistant ABS (UL Standard 94: V-0 Grade).
- All external parts have been specially selected for ease of refinishing and repainting.

## **4. HANDLING PRECAUTIONS**

The speaker is not magnetically shielded. Install it as far away as possible from television sets or computer's CRTs to avoid degradation in picture quality.

# 5. NOMENCLATURE

[Side Panel]

[Front Panel]

[Side Panel]

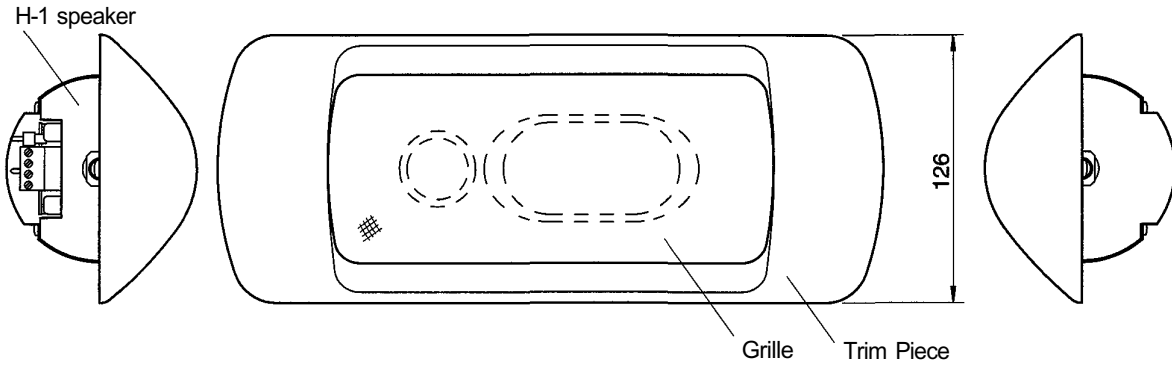

[Side Panel]

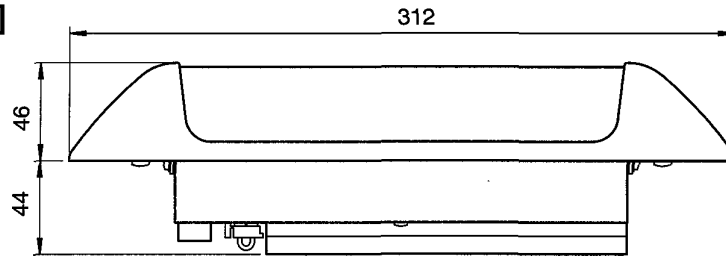

[Rear Panel]

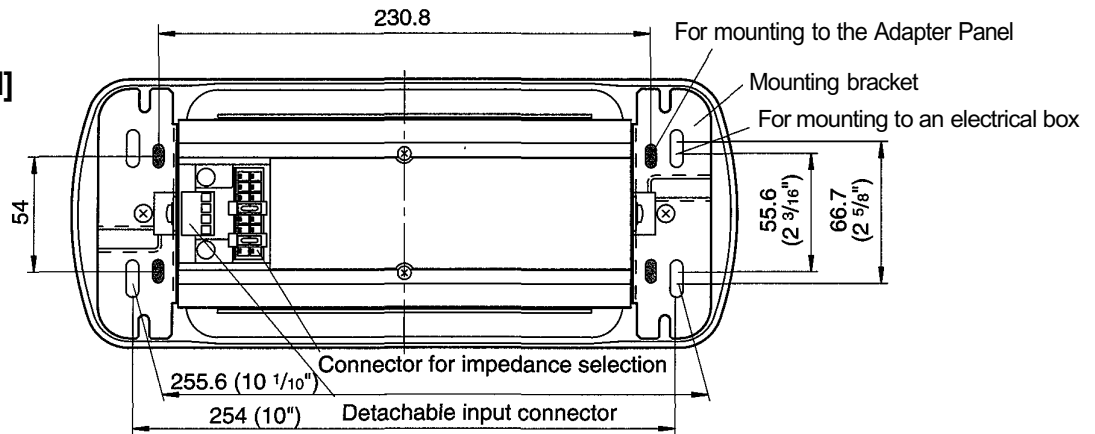

● Accessory (Adapter Panel)

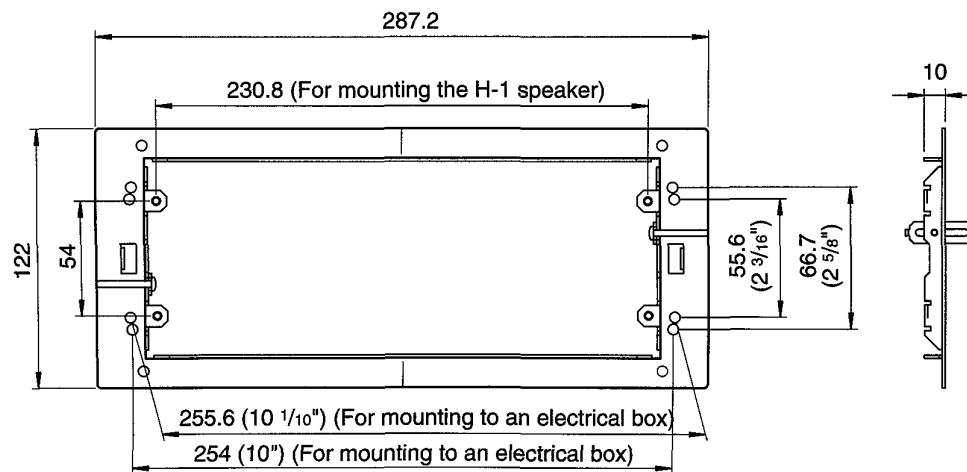

Unit : mm

## 6. INSTALLATION

### 6.1. Direct Wall/Ceiling Mounting Without Using an Electrical Box

#### Step 1. Adapter Panel mounting

- 1-1. Using the supplied hole pattern sheet as a guide, make an opening of the specified size in the wall or ceiling panel.

**Note**

The thickness of the suitable wall or ceiling panel is 9 to 30 mm.

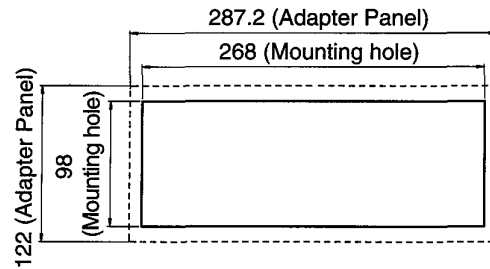

- 1-2. Loosen the two board clamp screws.

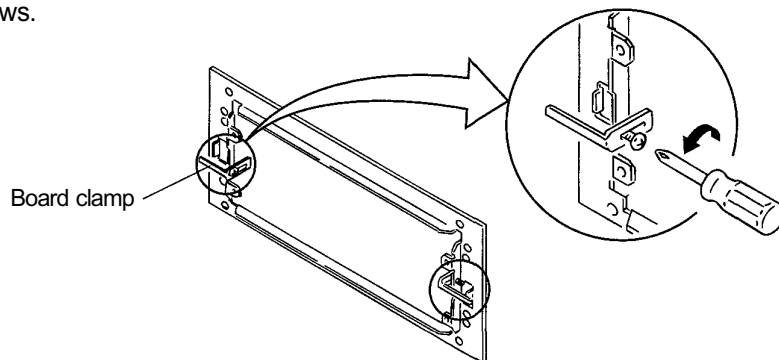

- 1-3. Place the Adapter Panel inside the opening, and set the panel to the desired position using the positioning tabs.

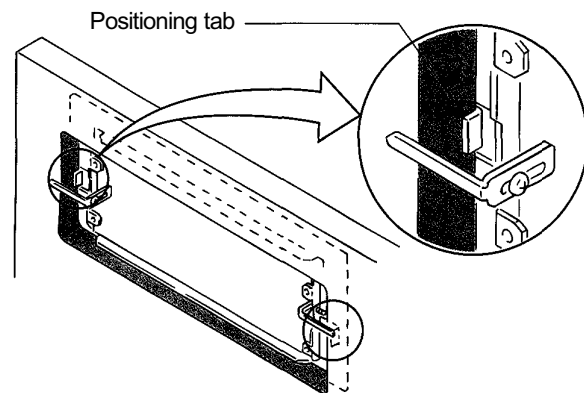
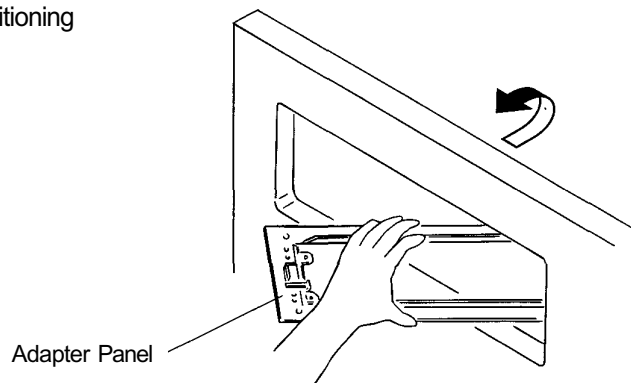

- 1-4. Clamp the wall or ceiling panel using the two board clamps, and secure with the clamp screws.

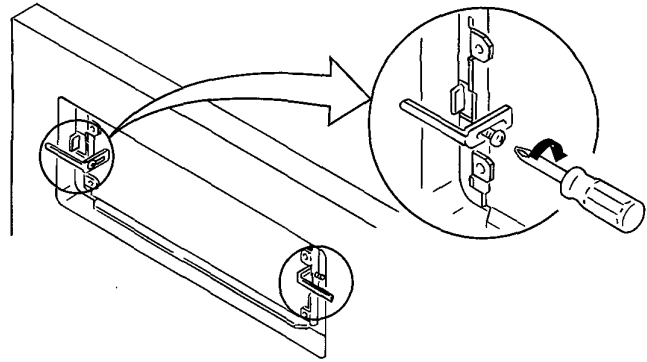

## Step 2. Wiring and impedance changes

- 2-1. Pull the cables out of the mounting hole in the wall or ceiling, then strip the insulation back about 5mm from the cable ends.

### Note

Usable cable: Solid cable or stranded cable ( $0.2 \text{ mm}^2$  -  $2.5 \text{ mm}^2$ ) (Corresponding to AWG No. 24-14)

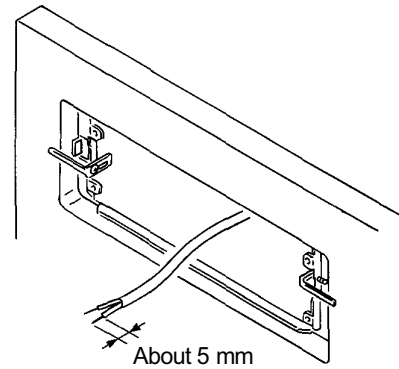

- 2-2. Remove the detachable input connector from the speaker, then loosen the connector screws with a small slot screwdriver.

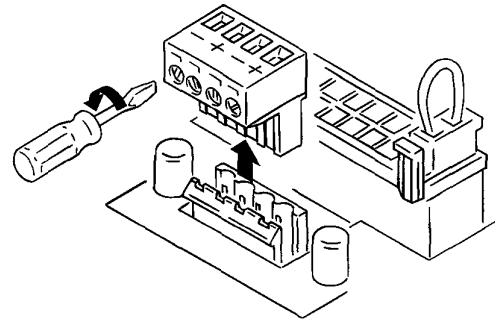

- 2-3. Insert the stripped cable ends into the input connector, and tighten the connector screws.

### Note

When not bridging connections, be sure to also tighten the screws of the terminals not in use to avoid vibration or rattling noise.

• When not bridging connections

• When bridging connections

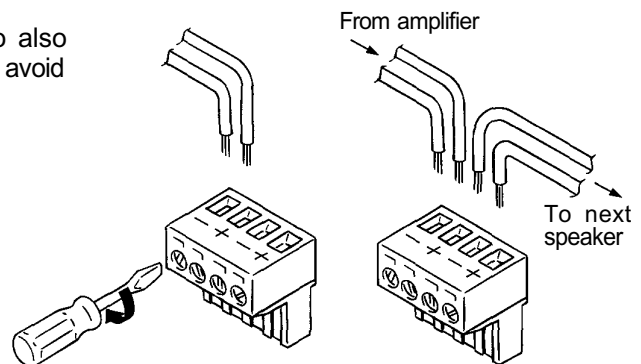

2-4. Attach two impedance selector sockets to the connector to select the desired impedance. Preset to 830  $\Omega$  (12 W for 100 V line and 6 W for 70 V line).

**Note**

The speaker is designed to be used for both 70 V and 100 V line applications. When using the 100 V line, do not select the "420  $\Omega$ " impedance, since the speaker itself or power amplifier may be damaged.

• When selecting 4  $\Omega$

• When selecting 16  $\Omega$

• When selecting 830  $\Omega$  (preset by the factory)

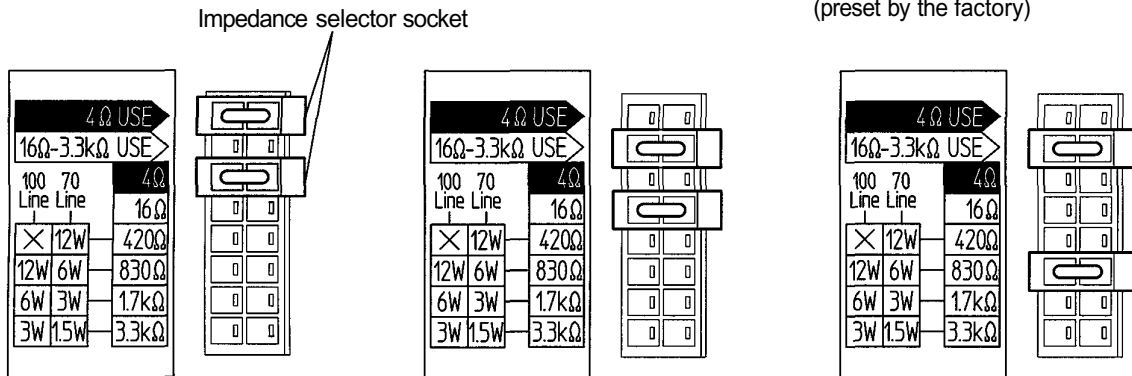

2-5. Insert the detachable input connector into the speaker socket.

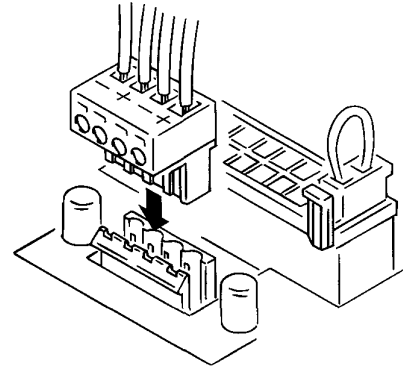

**Step 3. Mounting the speaker and Trim Piece**

3-1. Align the four inward-facing holes in the speaker's mounting bracket with the corresponding holes in the Adapter Panel mounting tabs, then mount the speaker to the panel using the four supplied screws (M4 x 25 screws with both the spring washers and plain washers).

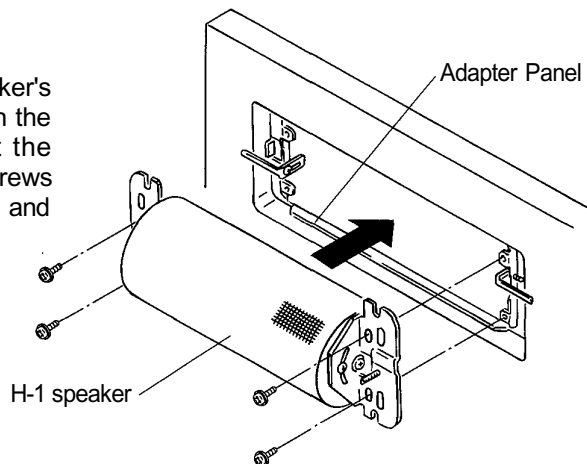

3-2. Loosen the angle adjustment screws. After adjusting the angle, retighten the screws.

**Tip**

The mounting angle can be adjusted for up to  $\pm 45^\circ$ . Since the mounting bracket is marked with mounting angles at  $15^\circ$  intervals, use this marking as a guide when adjusting the angle.

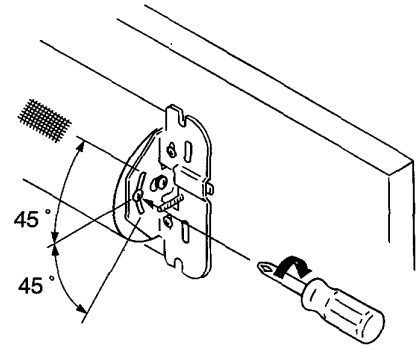
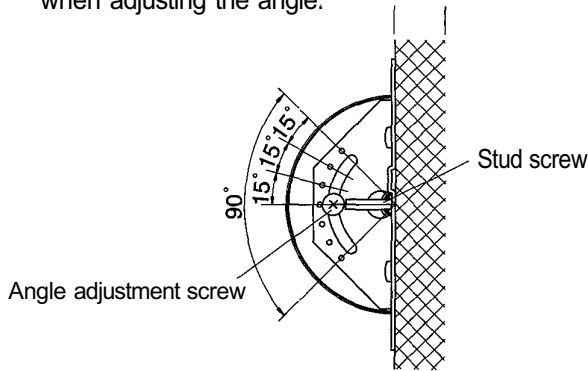

3-3. Align the two securing clips on the Trim Piece with the speaker's two stud screws, then push the Trim Piece onto the speaker until the Trim Piece is snug to the wall or ceiling surface.

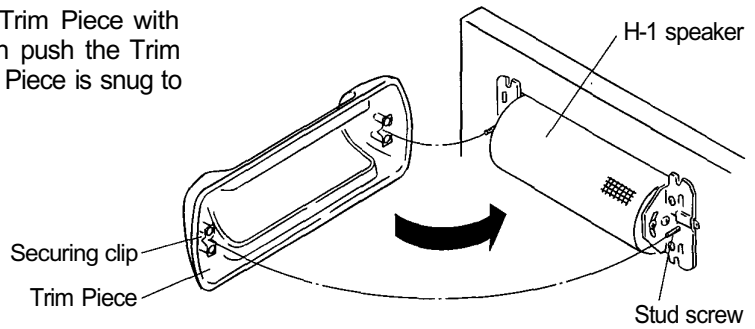

## 6.2. Mounting the Speaker to an Electrical Box Using The Adapter Panel

The H-1 speaker system can be mounted to walls or ceilings using an electrical box\*. Mount the Adapter Panel to the electrical box as shown below. Further mounting procedures are the same as detailed in Steps 2 and 3.

\* Distance between mounting holes (A) x (B):  
 254 mm (10") x 66.7 mm (2 5/8") or  
 255.6 mm (10 1/10") x 55.6 mm (2 3/16")

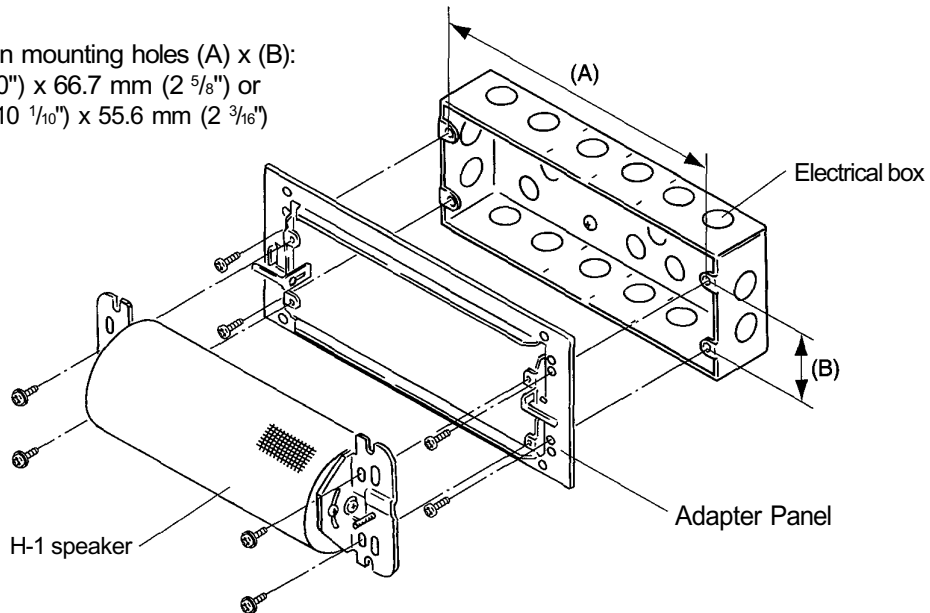

**Memo**

Electrical box mounting screws are attached to the H-1 speaker.



### 6.3. Mounting the Speaker Directly to an Electrical Box

The H1 speaker system can also be mounted directly to an electrical box\*. Follow Steps 2 and 3 for instructions. In this case, use the outward-facing holes in the mounting bracket when mounting to the wall or ceiling.

\* Distance between mounting holes (A) x (B): 254 mm (10") x 66.7 mm (2<sup>5</sup>/<sub>8</sub>") or 255.6 mm (10<sup>1</sup>/<sub>10</sub>") x 55.6 mm (2<sup>3</sup>/<sub>16</sub>")

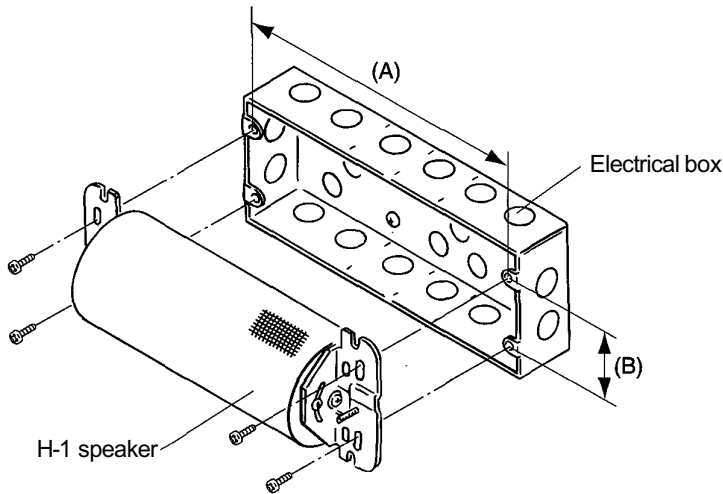

#### Memo

Electrical box mounting screws are attached to the H-1 speaker.

**Note:** The distance between the wall or ceiling surface and the box bottom surface must be 45 mm or more. When using the Raco 953 electrical box, be careful in installation because it is shallow.

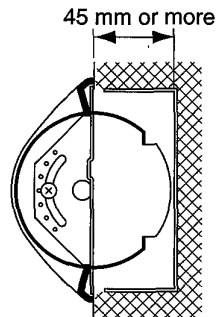

### 6.4. Removing the Trim Piece

When removing the Trim Piece for maintenance or repair, squeeze its sides by hand to create a gap between the Trim Piece and wall/ceiling, then insert a screwdriver blade into the gap and pry off the piece.

#### Caution

If you raise either right or left side of the Trim Piece by force, it may be broken. Pull the both sides out evenly and gradually.

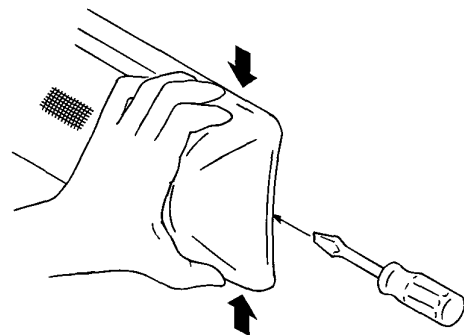

## 7. REPAINTING THE GRILLE AND TRIM PIECE

Follow the procedures below to change the color of the grille.

1. Remove the speaker's angle adjustment screw (1 piece).
2. Detach either of the two mounting brackets attached to the speaker.

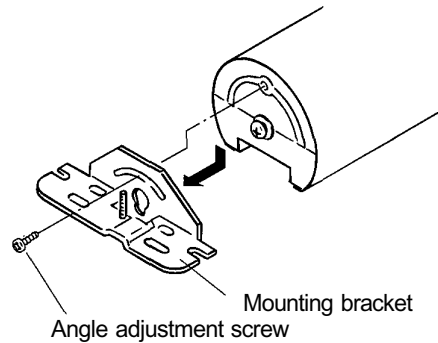

3. Remove the two grille mounting screws from the back of the speaker.
4. Slide the grille off the speaker.

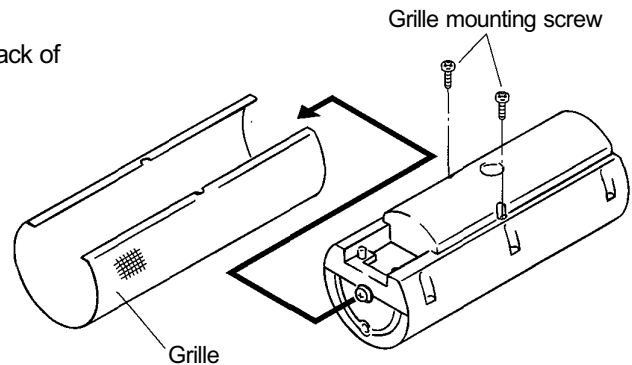

5. Paint both the grille and Trim Piece.

5-1. Wipe dirt off the grille and Trim Piece with a soft cloth moistened with a detergent before painting. Do not use volatile liquids such as thinner.

5-2. Uniformly spray a thin coating of paint over the grille and Trim Piece changing the spraying positions gradually.

### Notes

- Do not use a roller or brush to paint because the meshes of the grille could be clogged with paint.
- Use paint that is appropriate for the composition of the grille and Trim Piece.
  - Grille: Rolled steel plate
  - Trim Piece: Fire-resistant ABS resin
- Follow the instructions on the paint when painting.

5-3. After the paint dries, repeat Step 5-2 once or twice to repaint.

### Notes

- Be sure to repeat Step 5-2 at least twice.
- When repainting the front grille, place the grille upside down so that the surface is painted uniformly.

6. After the paint has dried, remount the grille to the speaker.

7. Attach the grille to the speaker with its two mounting screws.
8. Reattach the mounting bracket to the speaker with the angle adjustment screw.

## 8. PROTECTION CIRCUITRY INFORMATION

- The speaker has built-in overload protection circuitry. If there is an extremely high level input signal to the speaker, the overload protection circuitry is activated and cuts off the signal input to the speaker component.
- A sudden drop of the sound volume level during speaker operation indicates that the overload protection circuitry has been activated. In such a case, reduce the amplifier volume and wait. The protection circuitry is automatically reset after approximately 3-30 seconds. After the circuitry is reset, set the volume at a lower level than before.

### Important Note

This overload protection circuitry does not completely protect the speaker component. Depending on the nature of the excessive signal applied to the loudspeaker, there may be damage to the loudspeaker components before the protection circuitry can operate. Also, depending on the duration of the excessive input signal, the protection circuitry may be damaged and will not recover. Take special care that the excessive input is not applied to the speaker during use.

## 9. EQUALIZATION

- The H-1 is designed to provide good quality sound without additional equalization. However, by equalizing it as shown below, sounds can be made more powerful and intelligible.
- Using a digital signal processor such as DP-0202 or DP-0204, make the following equalization setting.

Filter	Frequency	Gain	Q
HPF	118 Hz	—	Q 0.707
PEQ	125 Hz	+10 dB	Q 1.800
PEQ	220 Hz	- 6.5 dB	Q 1.414
PEQ	5 kHz	+ 1.5 dB	Q 0.305
LPF	15.8 kHz	—	Q 0.500

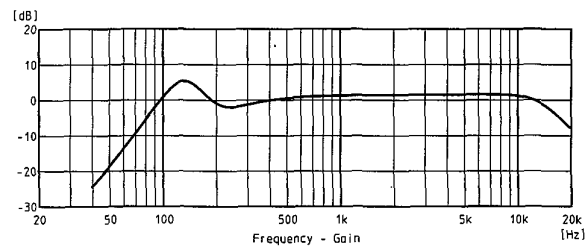

## 10. SPECIFICATIONS

Enclosure Type	Sealed type
Power Handling	90 W (continuous program input, 4 $\Omega$ loaded) 30 W (continuous pink noise input, 4 $\Omega$ loaded)* <sup>1</sup>
Rated Input	12 W (16 $\Omega$ or high impedance)
Rated Impedance	4 $\Omega$ , 16 $\Omega$ 70V line: 420 $\Omega$ (12 W), 830 $\Omega$ (6 W), 1.7k $\Omega$ (3 W), 3.3k $\Omega$ (1.5 W) 100 V line: 830 $\Omega$ (12 W), 1.7 k $\Omega$ (6 W), 3.3 k $\Omega$ (3 W)
Output Sound Pressure Level	85dB(1W, 1m, 2 $\pi$ loading)* <sup>2</sup>
Frequency Response	120 Hz to 20 kHz (—10 dB, 2 $\pi$ loading)
Crossover Frequency	5,000 Hz
Speaker Element	Low frequency: 8 cm x 5 cm cone woofer (neodymium magnet) High frequency: Balanced dome tweeter
Input Terminal	Detachable screw terminal, (+)/(-) 2 each (for bridging connection)
Usable Cable	Solid cable or stranded cable: 0.2 mm <sup>2</sup> - 2.5 mm <sup>2</sup> (Corresponding to AWG No. 24-14)
Material and Finish	Enclosure: Fire-resistant ABS resin (UL 94V-0), black Trim Piece: Fire-resistant ABS resin (UL 94V-0), white Grille: Rolled steel plate, white, paint Adapter Panel: Stainless steel
Dimensions	312(w) x 126(h) x 90(d) mm
Weight	1.5 kg (including Adapter Panel)

\*<sup>1</sup> Continuous 24 hours, band-limited pink noise (50 to 20,000 Hz)

\*<sup>2</sup> Pink noise (1,000 Hz to 10,000 Hz)

**Note** : The design and specifications are subject to change without notice for improvement.

### • Accessories

Adapter Panel .....	1
Pattern paper .....	1
Speaker mounting screw	
M4 x 25 (with spring washer and plain washer) .....	4
Electrical box mounting screw	
M4 x 25 .....	4
UNC No. 8-32 x 32 mm .....	4
Spring washer .....	4
Plain washer .....	4

