

**WARRANTY
REGISTRATION**

Register online today for a
chance to win a FREE Tripp Lite
product www.tripplite.com/warranty



Owner's Manual

DVI Over Cat5 Dual Display Extender / Splitter

Model: B140-002-DD

Package Contents	2
Product Features	2
Mounting	3
Standard Installation	4
Remote Repeater Installation	6
Troubleshooting	8
Warranty & Warranty Registration	11



1111 W. 35th Street, Chicago, IL. 60629 • www.tripplite.com/support

Copyright © 2013 Tripp Lite. All rights reserved.

Package Contents

- B140-002-DD Extender / Splitter Transmitter Unit
- External Power Supply (Input: 100-240V, 50/60Hz, 0.5A Output: 5V, 2A)
- Mounting Hardware
- Owner's Manual

Product Features

- Transmits a DVI-D Single-Link signal from a set of Dual DVI inputs to two sets of Dual Displays
- A B140-Series remote receiver is needed at each monitor
- For longer distances: Use a B140-1A0 or B140-1A0-WP active receiver to extend a 1920 x 1080 @ 60Hz signal up to 150 ft. from the transmitter (or a 1024 x 768 @ 60Hz signal up to 200 ft. from the transmitter)
- For shorter distances: Use a B140-1P0 or B140-1P0-WP passive receiver to extend a 1920 x 1080 @ 60Hz signal up to 50 ft. from the transmitter (or a 1024 x 768 @ 60Hz signal up to 100 ft. from the transmitter)
- Use 24AWG, Solid Wire Cat5e/6 cable, such as Tripp Lite's N202-Series, to achieve maximum distance and resolution
- Further expand the range and number of monitors by adding B140-110 remote repeater units
- Add up to three repeaters on each of the B140-002-DD channels, for a total of 4 displays per channel (An active receiver should be the last unit in a channel)
- A 1920 x 1080 @ 60Hz signal can be extended up to 125 ft. for each repeater added into a channel (or up to 175 ft. for a 1024 x 768 @ 60Hz signal)
- DVI 1.0 compliant
- HDCP compatible
- Mounting hardware included that allows the unit to be wall-mounted, rackmounted, or pole mounted
- Plug and play; no software or drivers required
- Compatible with all operating systems
- Compliant with the Federal Trade Agreements Act (TAA) for GSA Schedule purchases

Product Features

Optional Accessories:

- B140-1A0 DVI Over Cat5 Extender – Active Remote Receiver Unit
- B140-1A0-WP DVI Over Cat5 Extender – Active Remote Receiver Wallplate
- B140-1P0 DVI Over Cat5 Extender – Passive Remote Receiver Unit
- B140-1P0-WP DVI Over Cat5 Extender – Passive Remote Receiver Wallplate
- B140-110 DVI Over Cat5 Extender – Remote Repeater Unit
- N202-Series Cat6 24AWG, Solid Wire Patch Cables
- P561-Series DVI-D Single-Link Cables
- P566-Series DVI to HDMI Adapter Cables*

* When converting DVI to HDMI, only a video signal will be transmitted. DVI does not support audio.

Mounting

The B140-002-DD comes with mounting hardware that allows it to be mounted in a variety of ways. The following images show the different ways the included mounting brackets can be attached for different mounting methods.

Note: The images below show a B140-1A0, but the mounting hardware installation is the same for the B140-002-DD.

Wallmount 1



Wallmount 2



19" Rackmount



Pole Mount

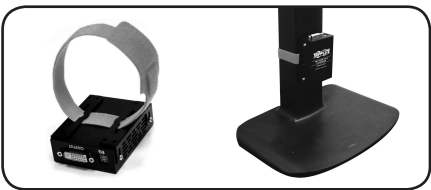

Standard Installation

Note:

1. Test to make sure that the entire installation works properly before pulling cables through ceilings/walls.
2. 24AWG, Solid Wire Cat5e/6 cable, such as Tripp Lite's N202-Series, is required to achieve maximum distance and resolution.
3. The signal from input port A is transmitted to RJ45 output ports 1A and 2A. The signal from input port B is transmitted to RJ45 output ports 1B and 2B. For your Dual Display installation to appear correctly in extended screen mode, locate the monitor connected to RJ45 port 1A next to the monitor connected to RJ45 port 1B. Likewise, locate the monitor connected to RJ45 port 2A next to the monitor connected to RJ45 port 2B.

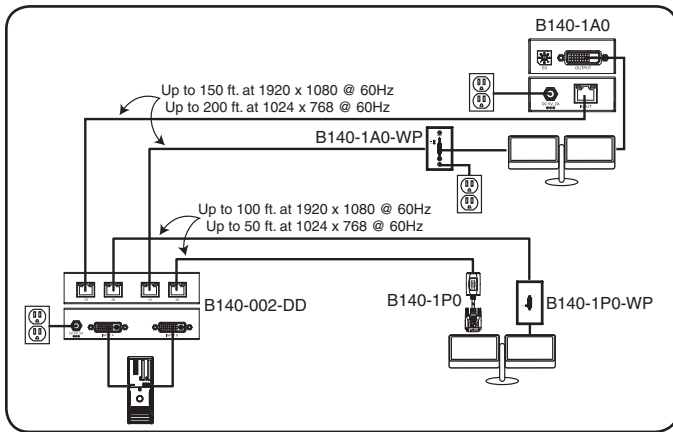

- 1 Make sure power to the DVI source is turned off.
- 2 Connect the first DVI port from the source to DVI input port A.
- 3 Connect the second DVI port from the source to DVI input port B.
- 4 Connect the external power supply to the B140-002-DD and plug it into a Tripp Lite Surge Suppressor, Power Distribution Unit (PDU), or Uninterruptible Power Supply (UPS). When receiving power, the Green RJ45 LEDs on the B140-002-DD will illuminate.

Standard Installation

- 5** Using Cat5e/6 cable, connect RJ45 port 1A to a B140-Series remote receiver unit.
- 6** Repeat step 5 to connect each RJ45 port to a B140-Series remote receiver unit.
- 7** **B140-1A0 and B140-1A0-WP only:** Connect the external power supply to the active receiver unit, and plug it into a Tripp Lite Surge Suppressor, PDU, or UPS. When receiving power, the Green RJ45 LED on the B140-1A0, and the Green Power LED on the B140-1A0-WP, will illuminate.
- 8** Repeat step 7 for each active receiver unit in the installation.
- 9** Connect a receiver unit to a monitor using a Tripp Lite P561-Series DVI-D Single-Link cable. If you have a B140-1P0, connect its built-in DVI connector to a monitor. When connected to and receiving power from a monitor, the Green RJ45 LED on the B140-1P0, and the Green Power LED on the B140-1P0-WP, will illuminate.
- 10** Repeat step 9 to connect each receiver unit to a monitor.
- 11** Turn on the power to the DVI source. The Orange RJ45 LEDs on the B140-002-DD and B140-1A0, and the Orange Activity LED on the B140-1A0-WP, will illuminate. The video image should now be displayed on the connected monitors.
- 12** **B140-1A0 and B140-1A0-WP only:** If necessary, use the Equalization control to adjust the video image.

Note: An improper Equalization setting can cause the monitor not to display an image at all. Try each setting until an acceptable image is displayed.

Remote Repeater Installation

Note:

1. Test to make sure that the entire installation works properly before pulling cables through ceilings/walls.
2. 24AWG, Solid Wire Cat5e/6 cable, such as Tripp Lite's N202-Series, is required to achieve maximum distance and resolution.
3. The signal from input port A is transmitted to RJ45 output ports 1A and 2A. The signal from input port B is transmitted to RJ45 output ports 1B and 2B. For your Dual Display installation to appear correctly in extended screen mode, locate the monitor connected to RJ45 port 1A next to the monitor connected to RJ45 port 1B. Likewise, locate the monitor connected to RJ45 port 2A next to the monitor connected to RJ45 port 2B.

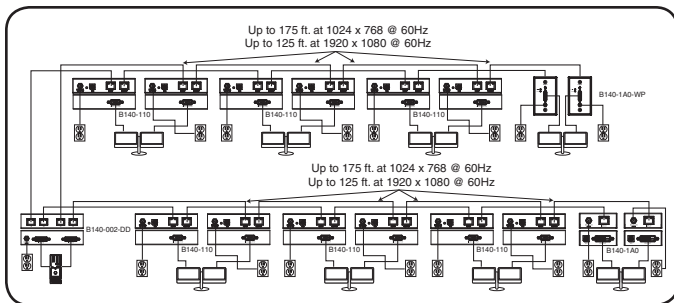

- 1 Make sure power to the DVI source is turned off.
- 2 Connect the first DVI port from the source to DVI input port A.
- 3 Connect the second DVI port from the source to DVI input port B.
- 4 Connect the external power supply to the B140-002-DD and plug it into a Tripp Lite Surge Suppressor, Power Distribution Unit (PDU), or Uninterruptible Power Supply (UPS). When receiving power, the Green RJ45 LEDs on the B140-002-DD will illuminate.
- 5 Using Cat5e/6 cable, connect RJ45 port 1A to the RJ45 input port of a B140-110 remote repeater unit.
- 6 Connect a monitor to the DVI output port on the repeater using a Tripp Lite P561-Series DVI-D Single-Link cable.

Remote Repeater Installation

- 7 Connect the external power supply to the repeater and plug it into a Tripp Lite Surge Suppressor, PDU, or UPS. The Green Power LED and the Green RJ45 LEDs illuminate to indicate the unit is receiving power.

Add up to 3 repeaters per channel, for a total of 4 displays (an active remote receiver should be the last unit in a channel). To connect additional repeaters, proceed to step 8. To finish your installation with a B140-1A0 or B140-1A0-WP receiver, proceed to step 11.

- 8 Using Cat5e/6 cable, connect the RJ45 output port on the first repeater to the RJ45 input port on a second repeater.

- 9 Connect a monitor to the DVI output port on the repeater using a Tripp Lite P561-Series DVI-D Single-Link cable.

- 10 Connect the external power supply to the repeater and plug it into a Tripp Lite Surge Suppressor, PDU, or UPS. The Green Power LED and the Green RJ45 LEDs illuminate to indicate the unit is receiving power.

To add a third repeater, repeat steps 8 through 10. To finish your installation with a B140-1A0 or B140-1A0-WP receiver, proceed to step 11.

- 11 Using Cat5e/6 cable, connect the RJ45 output port on the last repeater to the RJ45 input port on a B140-1A0 or B140-1A0-WP receiver.

- 12 Connect a monitor to the DVI output port on the receiver using a Tripp Lite P561-Series DVI-D Single-Link cable.

- 13 Connect the external power supply to the active receiver unit, and plug it into a Tripp Lite Surge Suppressor, PDU, or UPS. When receiving power, the Green RJ45 LED on the B140-1A0, and the Green Power LED on the B140-1A0-WP, will illuminate.

Repeat steps 5 through 13 for each RJ45 output port on the B140-002-DD.

Note: See Note number 3 at the beginning of the Remote Repeater Installation section, and reference the installation diagram to ensure the correct video signals are transmitted to the monitors in your dual display installation.

Remote Repeater Installation

- 14 Turn on the power to the DVI source. The Orange RJ45 LED's on the B140-002-DD, B140-110, and B140-1A0, and the Orange Activity LED on the B140-1A0-WP, will illuminate. The video image should now be displayed on the connected monitors.
- 15 If necessary, use the Equalization control on the B140-110, B140-1A0, and/or B140-1A0-WP to adjust the video image.

Note: An improper Equalization setting can cause the monitor not to display an image at all. Try each setting until an acceptable image is displayed.

Troubleshooting

If you are unable to get an acceptable image after following the installation instructions, try the troubleshooting tips below.

- 1 Is the external power supply that came with the product connected and plugged into a working power source? For the product to function properly, it must be connected to and receiving power from the external power supply.
- 2 Was the power to the DVI source turned off prior to installation? If not, restart your computer.
- 3 Have you adjusted the Equalization setting on the repeater and/or receiver units? There are built-in Equalization adjustment knobs on every repeater and active receiver, which can be adjusted to obtain the best picture quality. Use the mini screwdriver included with the product to adjust this setting until an acceptable image is displayed.

Note: An improper Equalization setting can cause the monitor not to display an image at all. Try each setting until an acceptable image is displayed.

Troubleshooting

- 4** What resolution are you trying to reach? Tripp Lite's DVI over Cat5 extenders are tested to support up to 1920 x 1080 @ 60Hz video resolution (See the Product Features section or the installation diagrams in this manual for details on max distance and resolution when using the repeater and the different receivers). The shorter the extension distance, the higher the resolution you will be able to obtain. If you are not able to get an acceptable image after adjusting the Equalization setting, try lowering your computer's video resolution and/or adjusting the refresh rate.
- 5** What type of cabling are you using? Inferior cabling can result in poor performance, so it is important that you use cables that can support the video resolution you are trying to obtain. To achieve maximum distance and resolution, 24AWG solid wire UTP cable must be used. Tripp Lite's N202-Series Cat6 cables are made with 24AWG solid wire, as are the N022-01K-GY (Cat5) and N222-01K-GY bulk cables. Also, the DVI cables you are using must support the resolution you are trying to obtain. Inexpensive, low quality DVI cables may not support the maximum resolution. It is recommended that you use Tripp Lite's P561-Series DVI-D Single-Link cables, as they have been tested to work with the B140-Series extender products.
- 6** Test your cables to ensure they are working properly. For example, connect your DVI cables between a source and monitor that you know works to see if the cable is functioning. For Cat5e/6 cable, connect it between a computer and a network to verify that it establishes a network connection.
- 7** Do you have any patch panels or other devices in between the transmitter, repeater, and receiver units? Tripp Lite's DVI over Cat5 extender products were designed to be connected directly from the transmitter to the repeater and/or receiver via UTP cable. The more connection points that are in between the source and the remote monitor, the more likely it will be that signal degradation will occur, causing poor performance. If you have a patch panel or other device in between, it should be removed from the installation.

Troubleshooting

- 8** Check your cabling for any damages that may have occurred during installation. If a cable connector is loosened from pulling through ceilings/walls, or the cable jacket is damaged causing the wiring to be exposed, you will not be able to achieve maximum performance.
- 9** Are the transmitter, repeater, and/or receiver located in an area that exposes them to higher temperatures? If the product is overheated, it will not function properly.
- 10** Are you using a VGA to DVI adapter with this product? The B140-Series extenders support DVI-D (Digital) only, and will not function if connected to a VGA computer or monitor.
- 11** If using a DVI to HDMI adapter with this product, you will only be able to transmit a video signal. DVI does not support audio, and will not be able to send an audio signal to an HDMI display.
- 12** The signal from input port A is transmitted to RJ45 output ports 1A and 2A. The signal from input port B is transmitted to RJ45 output ports 1B and 2B. For your Dual Display installation to appear correctly in extended screen mode, locate the monitor connected to RJ45 port 1A next to the monitor connected to RJ45 port 1B. Likewise, locate the monitor connected to RJ45 port 2A next to the monitor connected to RJ45 port 2B. Reference the installation diagrams in this manual for examples of a correct setup.
- 13** If you have followed the proper installation procedures, and all monitors continue to display the same image, you may have to go into your computer's Display Settings menu and activate Extended monitor mode. If your computer is set to Mirror (or Duplicate) monitor mode, the same image will be displayed on both screens.

Warranty & Warranty Registration

1-Year Limited Warranty

TRIPP LITE warrants its products to be free from defects in materials and workmanship for a period of one (1) year from the date of initial purchase. TRIPP LITE's obligation under this warranty is limited to repairing or replacing (at its sole option) any such defective products. To obtain service under this warranty, you must obtain a Returned Material Authorization (RMA) number from TRIPP LITE or an authorized TRIPP LITE service center. Products must be returned to TRIPP LITE or an authorized TRIPP LITE service center with transportation charges prepaid and must be accompanied by a brief description of the problem encountered and proof of date and place of purchase. This warranty does not apply to equipment which has been damaged by accident, negligence or misapplication or has been altered or modified in any way.

EXCEPT AS PROVIDED HEREIN, TRIPP LITE MAKES NO WARRANTIES, EXPRESS OR IMPLIED, INCLUDING WARRANTIES OF MERCHANTABILITY AND FITNESS FOR A PARTICULAR PURPOSE. Some states do not permit limitation or exclusion of implied warranties; therefore, the aforesaid limitation(s) or exclusion(s) may not apply to the purchaser.

EXCEPT AS PROVIDED ABOVE, IN NO EVENT WILL TRIPP LITE BE LIABLE FOR DIRECT, INDIRECT, SPECIAL, INCIDENTAL OR CONSEQUENTIAL DAMAGES ARISING OUT OF THE USE OF THIS PRODUCT, EVEN IF ADVISED OF THE POSSIBILITY OF SUCH DAMAGE. Specifically, TRIPP LITE is not liable for any costs, such as lost profits or revenue, loss of equipment, loss of use of equipment, loss of software, loss of data, costs of substitutes, claims by third parties, or otherwise.

WARRANTY REGISTRATION

Visit www.tripplite.com/warranty today to register the warranty for your new Tripp Lite product. You'll be automatically entered into a drawing for a chance to win a FREE Tripp Lite product!*

* No purchase necessary. Void where prohibited. Some restrictions apply. See website for details.

FCC Notice, Class B

This device complies with part 15 of the FCC Rules. Operation is subject to the following two conditions: (1) This device may not cause harmful interference, and (2) this device must accept any interference received, including interference that may cause undesired operation.

Note: This equipment has been tested and found to comply with the limits for a Class B digital device, pursuant to part 15 of the FCC Rules. These limits are designed to provide reasonable protection against harmful interference in a residential installation. This equipment generates, uses and can radiate radio frequency energy and, if not installed and used in accordance with the instructions, may cause harmful interference to radio communications. However, there is no guarantee that interference will not occur in a particular installation. If this equipment does cause harmful interference to radio or television reception, which can be determined by turning the equipment off and on, the user is encouraged to try to correct the interference by one or more of the following measures:

- Reorient or relocate the receiving antenna.
- Increase the separation between the equipment and receiver.
- Connect the equipment into an outlet on a circuit different from that to which the receiver is connected.
- Consult the dealer or an experienced radio/TV technician for help.

Any changes or modifications to this equipment not expressly approved by Tripp Lite could void the user's authority to operate this equipment.

Warranty & Warranty Registration

WEEE Compliance Information for Tripp Lite Customers and Recyclers (European Union)



Under the Waste Electrical and Electronic Equipment (WEEE) Directive and implementing regulations, when customers buy new electrical and electronic equipment from Tripp Lite they are entitled to:

- Send old equipment for recycling on a one-for-one, like-for-like basis (this varies depending on the country)
- Send the new equipment back for recycling when this ultimately becomes waste

WARNING

Use of this equipment in life support applications where failure of this equipment can reasonably be expected to cause the failure of the life support equipment or to significantly affect its safety or effectiveness is not recommended. Do not use this equipment in the presence of a flammable anesthetic mixture with air, oxygen or nitrous oxide.

Tripp Lite follows a policy of continuous improvement. Product specifications are subject to change without notice.



1111 W. 35th Street, Chicago, IL. 60629 • www.tripplite.com/support