

# Owner's Manual

## Rackmount Network Switch with Built-in PDU

**Model: NSU-G16**  
**(Series Number: AG-00C6)**

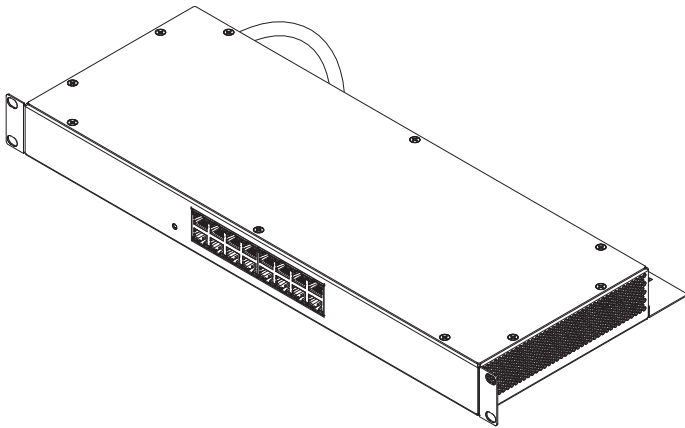

### PROTECT YOUR INVESTMENT!

Register your product for quicker service  
and ultimate peace of mind.

You could also win an  
ISOBAR6ULTRA surge protector—  
a \$100 value!



[www.tripplite.com/warranty](http://www.tripplite.com/warranty)

# TRIPP-LITE



1111 W. 35th Street, Chicago, IL 60609 USA • [www.tripplite.com/support](http://www.tripplite.com/support)

Copyright © 2016 Tripp Lite. All rights reserved.

# Important Safety Instructions



## **SAVE THESE INSTRUCTIONS!**

This manual contains important instructions and warnings that should be followed during the installation, operation and storage of this Tripp Lite product. Failure to heed these warnings may affect your warranty.

### **PDU/Switch Location Warnings**

- The switch provides the convenience of multiple outlets, but DOES NOT provide surge or line noise protection for connected equipment.
- The switch is designed for indoor use only, in a controlled environment, away from excess moisture, temperature extremes, conductive contaminants, dust or direct sunlight.
- For best performance, maintain an indoor temperature between 32° F and 104° F (0° C and 40° C) with relative humidity between 10% and 90% (non-condensing).
- Leave adequate space around all sides of the switch for proper ventilation.
- Keep the switch away from high-frequency, strong-current devices (e.g., radio transmitting stations, transmitters and broadband amplifiers).
- Use electromagnetic shielding (if required).
- For rackmount configuration, ensure that both the rack and switch are properly grounded.
- If the switch is not rack mounted, securely place it on a sturdy, flat surface.
- Improper installation can cause product damage that is not covered by the warranty.
- Do not expose the network switch's connected networking cables to outdoor elements.
- Do not use this product near water (e.g., in a wet basement, or near a swimming pool).

### **PDU/Switch Connection Warnings**

- Use of this equipment in life support applications where failure of this equipment can reasonably be expected to cause the failure of the life support equipment or to significantly affect its safety or effectiveness is not recommended. Do not use this equipment in the presence of a flammable anesthetic mixture with air, oxygen or nitrous oxide.
- Keep the switch's input power off during installation.
- Use only the power cord that came included with the switch.
- Make sure the power supply voltage matches the specifications indicated on the switch.
- The total power requirement for equipment connected to the switch must not exceed the maximum load rating for the PDU's circuit breaker.
- Do not connect the switch to an ungrounded outlet or to extension cords or adapters that eliminate the connection to ground.
- Do not drill into or attempt to open any part of the switch housing. There are no user-serviceable parts inside.
- Do not attempt to modify the switch, including the input plugs and power cables.
- Do not attempt to use the switch if any part of it becomes damaged.
- Make sure network cables are properly seated. A clicking sound will be made when a cable is installed correctly.
- If the power cord is damaged, do not attempt to connect the switch. Contact a Tripp Lite Service Representative for assistance.
- Never attempt to install or use the switch during a thunderstorm.

# Important Safety Instructions

## Avertissement concernant l'emplacement de la PDU/du commutateur

- Le commutateur fournit des prises multiples pratiques, mais elle ne FOURNIT PAS de protection contre les surtensions ou les bruits de ligne pour l'équipement connecté.
- Le commutateur est conçue pour être utilisée à l'intérieur uniquement, dans un environnement contrôlé, à l'écart de l'excès d'humidité, des températures extrêmes, des contaminants conducteurs, de la poussière et de la lumière directe du soleil.
- Pour un rendement optimal, maintenez la température intérieure entre 32 °F et 104 °F (0 °C et 40 °C) avec une humidité relative comprise entre 10 et 90 % (sans condensation).
- Laisser suffisamment d'espace tout autour du commutateur pour assurer une bonne ventilation.
- Garder le commutateur à l'écart des appareils haute fréquence et à courant fort (p. ex. station émettrice de radio, transmetteurs et amplificateurs à large bande).
- Utiliser une protection électromagnétique (le cas échéant).
- Pour une configuration de montage en bâti, s'assurer que le bâti et le commutateur sont correctement mis à la masse.
- Si le commutateur n'est pas monté en bâti, le placer solidement sur une surface solide et à plat.
- Une mauvaise installation risque de causer des dommages au produit qui ne sont pas couverts par la garantie.
- Ne pas exposer les câbles de réseautage connectés du commutateur réseau aux éléments extérieurs.
- Ne pas utiliser ce produit à proximité de l'eau (p. ex. dans un sous-sol humide ou à proximité d'une piscine).

## Avertissement concernant la connexion de la PDU/du commutateur

- Il n'est pas recommandé d'utiliser cet équipement dans les applications de soutien vital où une panne de cet équipement serait susceptible de causer une panne de l'équipement de soutien vital ou d'affecter sérieusement sa sécurité ou son efficacité. Ne pas utiliser cet équipement dans un milieu où il existe un mélange anesthésique inflammable avec de l'air, de l'oxygène ou de l'oxyde nitreux.
- Garder l'alimentation d'entrée du commutateur hors tension durant l'installation.
- Utiliser uniquement le cordon d'alimentation qui était fourni avec le commutateur.
- S'assurer que la tension d'alimentation correspond aux spécifications indiquées sur le commutateur.
- La puissance totale requise pour l'équipement connecté au commutateur ne doit pas excéder la charge nominale maximum pour le disjoncteur de la PDU.
- Ne pas connecter le commutateur dans une prise non mise à la masse ou des rallonges électriques ou des adaptateurs qui éliminent la connexion à la masse.
- Ne pas percer ou tenter d'ouvrir une quelconque partie du boîtier du commutateur. Il n'existe aucune pièce réparable par l'utilisateur à l'intérieur.
- Ne pas tenter de modifier le commutateur, y compris les fiches d'entrée et les câbles d'alimentation.
- Ne pas tenter d'utiliser le commutateur si une de ses pièces est endommagée.
- S'assurer que les câbles du réseau reposent correctement en place. Un bruit de cliquetis sera émis lorsqu'un câble est installé correctement.
- Si le cordon d'alimentation est endommagé, ne pas tenter de connecter le commutateur. Contactez votre représentant(e) Tripp Lite pour obtenir de l'aide.
- Ne jamais essayer d'installer ou d'utiliser le commutateur pendant un orage.

# Product Features

## Front Panel:

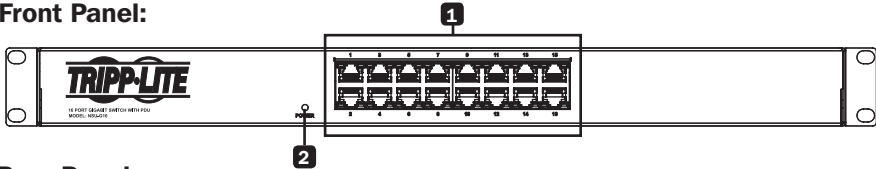

## Rear Panel:

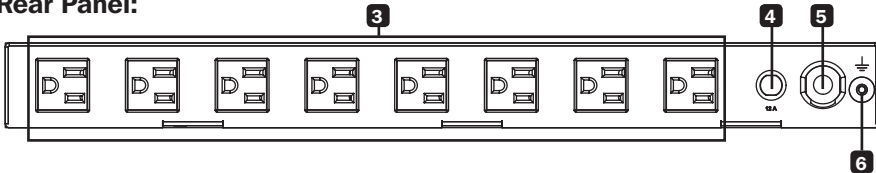

- 1 Gigabit Ethernet Ports:** These 16 twisted-pair RJ-45 ports support auto-negotiable 10/100/1000 Mbps and auto MDI/MDIX cross-over detection functions for true “plug and play” capability. There are two green LEDs per RJ-45 port. The left LED blinks when the port is active. The right LED is off at 10 and 100 Mbps and lights up at 1000 Mbps, remaining lit while at that speed.

*Note: Not compatible with PoE (Power Over Ethernet) applications.*

- 2 Power ON/OFF LED:** An LED illuminates to indicate that the switch is receiving power.
- 3 NEMA 5-15R Outlets:** This switch includes eight NEMA 5-15R receptacles.
- 4 Circuit Breaker:** If the current drawn by the equipment connected to the PDU exceeds the Maximum Load Rating, the 12A thermal circuit breaker will trip to prevent possible damage and its plunger will pop up. If this happens, disconnect excess equipment and allow the breaker to cool at least one minute before depressing the plunger to reset the unit.
- 5 Input:** AC power input from a connected UPS system or alternate source.
- 6 Grounding Lug:** Use this screw to connect your switch to ground.

# Quick Installation

## 1U Rackmount Installation

- 1** Mount the switch using either the four cage nuts **A**, washers **B** and screws **C** provided or four user-supplied rackmount screws **D**. The user must determine the fitness of the rackmount screws to hold the unit in the rack before installation.
- 2** Connect the switch to a properly grounded outlet. The POWER LED will illuminate when the switch turns on.
- 3** Connect the network cables to the network switch.
- 4** Connect equipment to the PDU outlets. Make sure the load connected does not exceed the PDU's circuit breaker rating.

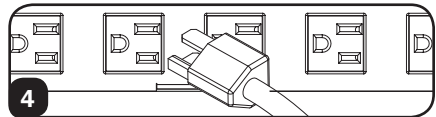
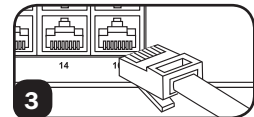
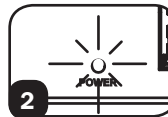
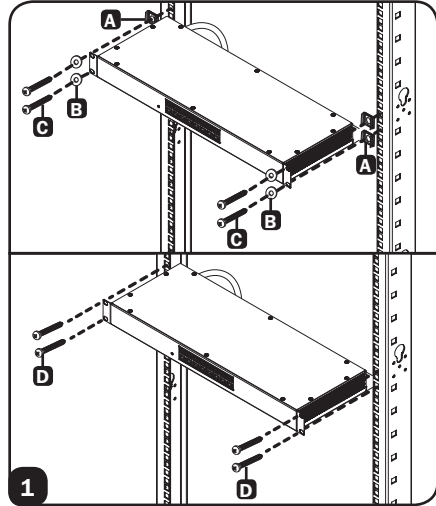

# Warranty & Product Registration

## 5-Year Limited Warranty

TRIPP LITE warrants its products to be free from defects in materials and workmanship for a period of five (5) years from the date of initial purchase. TRIPP LITE's obligation under this warranty is limited to repairing or replacing (at its sole option) any such defective products. To obtain service under this warranty, you must obtain a Returned Material Authorization (RMA) number from TRIPP LITE or an authorized TRIPP LITE service center. Products must be returned to TRIPP LITE or an authorized TRIPP LITE service center with transportation charges prepaid and must be accompanied by a brief description of the problem encountered and proof of date and place of purchase. This warranty does not apply to equipment which has been damaged by accident, negligence or misapplication or has been altered or modified in any way.

EXCEPT AS PROVIDED HEREIN, TRIPP LITE MAKES NO WARRANTIES, EXPRESS OR IMPLIED, INCLUDING WARRANTIES OF MERCHANTABILITY AND FITNESS FOR A PARTICULAR PURPOSE. Some states do not permit limitation or exclusion of implied warranties; therefore, the aforesaid limitation(s) or exclusion(s) may not apply to the purchaser.

EXCEPT AS PROVIDED ABOVE, IN NO EVENT WILL TRIPP LITE BE LIABLE FOR DIRECT, INDIRECT, SPECIAL, INCIDENTAL OR CONSEQUENTIAL DAMAGES ARISING OUT OF THE USE OF THIS PRODUCT, EVEN IF ADVISED OF THE POSSIBILITY OF SUCH DAMAGE. Specifically, TRIPP LITE is not liable for any costs, such as lost profits or revenue, loss of equipment, loss of use of equipment, loss of software, loss of data, costs of substitutes, claims by third parties, or otherwise.

## PRODUCT REGISTRATION

Visit [www.tripplite.com/warranty](http://www.tripplite.com/warranty) today to register your new Tripp Lite product. You'll be automatically entered into a drawing for a chance to win a FREE Tripp Lite product!\*

\* No purchase necessary. Void where prohibited. Some restrictions apply. See website for details.

## Regulatory Compliance Identification Numbers

For the purpose of regulatory compliance certifications and identification, your Tripp Lite product has been assigned a unique series number. The series number can be found on the product nameplate label, along with all required approval markings and information. When requesting compliance information for this product, always refer to the series number. The series number should not be confused with the marketing name or model number of the product.

## FCC Notice, Class A

This device complies with part 15 of the FCC Rules. Operation is subject to the following two conditions: (1) This device may not cause harmful interference, and (2) this device must accept any interference received, including interference that may cause undesired operation.

Note: This equipment has been tested and found to comply with the limits for a Class A digital device, pursuant to part 15 of the FCC Rules. These limits are designed to provide reasonable protection against harmful interference when the equipment is operated in a commercial environment. This equipment generates, uses, and can radiate radio frequency energy and, if not installed and used in accordance with the instruction manual, may cause harmful interference to radio communications. Operation of this equipment in a residential area is likely to cause harmful interference in which case the user will be required to correct the interference at his own expense. The user must use shielded cables and connectors with this equipment. Any changes or modifications to this equipment not expressly approved by Tripp Lite could void the user's authority to operate this equipment.

## WEEE Compliance Information for Tripp Lite Customers and Recyclers (European Union)



Under the Waste Electrical and Electronic Equipment (WEEE) Directive and implementing regulations, when customers buy new electrical and electronic equipment from Tripp Lite they are entitled to:

- Send old equipment for recycling on a one-for-one, like-for-like basis (this varies depending on the country)
- Send the new equipment back for recycling when this ultimately becomes waste

Tripp Lite has a policy of continuous improvement. Specifications are subject to change without notice.

# Notes



1111 W. 35th Street, Chicago, IL 60609 USA • [www.tripplite.com/support](http://www.tripplite.com/support)