

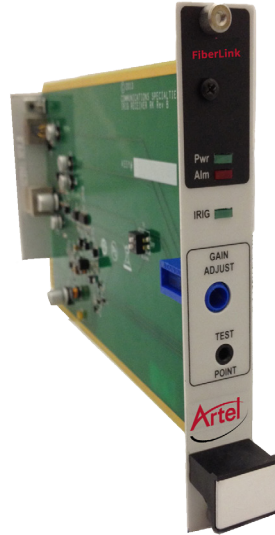

# FiberLink® XA/RA-1900, XA-1903 IRIG/NASA/NBS Time Code Formats over Fiber

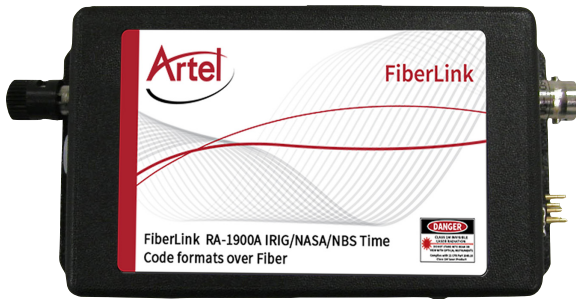

## FEATURES

### Ideal applications for Military and the Aerospace Industries

Transmits IRIG and similar NASA and NBS standard instrumentation time-code formats up to 100 kHz

Combinations of three different units may be configured to provide point-to-point, point-to-multipoint

Built-in regulated power supplies allow operation from unregulated AC or DC sources

Transmits at 850 nm or 1310 nm over standard multimode or single mode fiber

XA/RA-1900 cards fit the 6000A card cage. The XA-1903 is provided in a 19" rackmountable enclosure

## Fiber optic transmission of IRIG time-code signals, configured for point-to-point, point-to-multipoint signal distribution

The FiberLink XA/RA-1900A and XR-1900 fiber optic systems transmit IRIG and similar NASA and NBS standard instrumentation time-code formats over standard multimode or single mode fiber at 850 nm or 1310 nm.

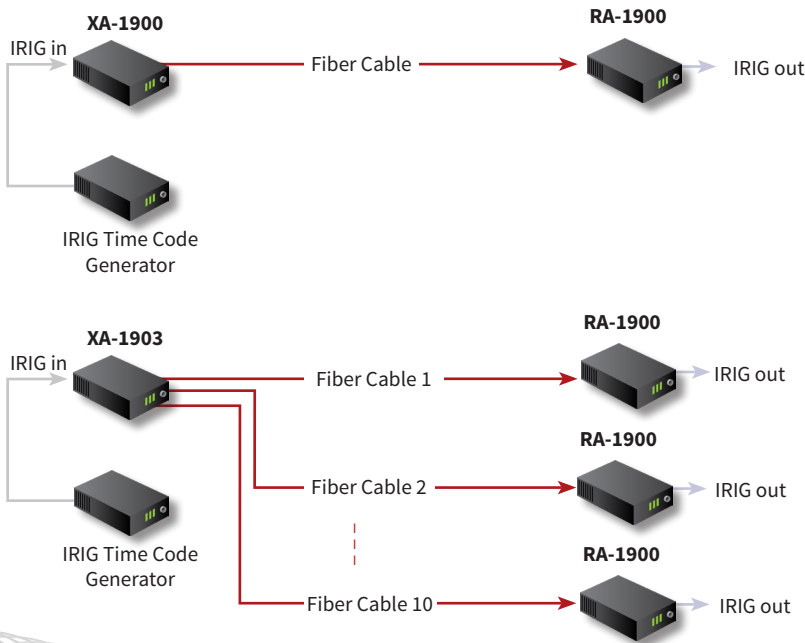

## SPECIFICATIONS

### Data Specifications

Number of Channels	1
Number of Outputs per Channel	XA-1900 & RA-1900: 1, XA-1903: 10
IRIG Compatibility	A through H
System Bandwidth (+0, -3 dB)	20 Hz to 100 kHz
Input/Output Load Impedance	600 Ohms nominal
Input/Output Signal Voltage	1 volt rms
Signal/Noise Ratio	67 dB typical
Noise Floor (full bandwidth)	1.3 mv rms maximum

### General Specifications

Number of Fibers:	
XA-1900 & RA-1900:	1 fiber
XA-1903:	10 fibers
Operating Temperature:	
	-20 to +60o C
Operating Power (per unit):	
	+15 to +25 volts DC @ 250 mA or 14 to 18 volts AC, 50/60 Hz
Dimensions:	
XA-1900 & RA-1900:	5 W x 1.25 H x 2.5 L (inches) 127 W x 32 H x 64 L (mm)
XA-1903:	19 W x 1.75 H x 6.5 L (inches) 483 W x 45 H x 165 L (mm)
Weight:	
XA-1900 & RA-1900:	Approx. 1 lb; 0.45 kg
XA-1903:	Approx. 3 lbs; 1.36 kg
Optical Connectors:	
	ST: Multimode ST or FCPC: Single Mode
Optical Wavelength:	
	850 nm or 1310 nm MM 1310 nm SM
Optical Fiber:	
	50 or 62.5 micron multimode fiber 8/10 micron single mode
System Delay:	
	< 5 uSec; Measured from a Transmitter input to a Receiver output with 1 meter of fiber. Does not include any additional length of fiber. Consult fiber cable manufacturer for specific propagation delay. An approximate fiber cable propagation delay is approximately 5 uSec/km.
MTBF:	
	XA-1900 series: 195,000 hours RA-1900 series: 181,000 hours XA-1903 series: 74,000 hours

### Operating Loss Budget & Maximum Usable Distance\*

Wavelength	Loss (dB)	Distance (km)
850nm MM	0-10dB	0-3.5 (62.5u)
850nm MM	0-10dB	0-4 (50u)
1310nm MM	0-13dB	0-10 (62.5u)
1310nm MM	0-13dB	0-12 (50u)
1310nm SM	0-13dB	0-20

For system to operate properly, operating loss budget must not be exceeded.



UPDATED 11/01/2016

All specifications subject to change without notice. ©2016



### Ordering Information

Part Number	Description	Fibers
XA-1900-1	Transmitter, 850 nm, Multimode, Box, ST	1
XA-1900-C1S	Transmitter, 850 nm, Multimode, Card, ST	1
XA-1900-3	Transmitter, 1310 nm, Multimode, Box, ST	1
XA-1900-C3S	Transmitter, 1310 nm, Multimode, Card, ST	1
XA-1900-7-ST	Transmitter, 1310 nm, Single Mode, Box, ST	1
XA-1900-C7S	Transmitter, 1310 nm, Single Mode, Card, ST	1
RA-1900-1	Receiver, 850 nm, Multimode, Box, ST	1
RA-1900-C1S	Receiver, 850 nm, Multimode, Card, ST	1
RA-1900-3	Receiver, 1310 nm, Multimode, Box, ST	1
RA-1900-C3S	Receiver, 1310 nm, Multimode, Card, ST	1
RA-1900-7-ST	Receiver, 1310 nm, Single Mode, Box, ST	1
RA-1900-C7S	Receiver, 1310 nm, Single Mode, Card, ST	1
XA-1903-1	Transmitter, 850 nm, Multimode, ST	10
XA-1903-3	Transmitter, 1310 nm, Multimode, ST	10
XP-1000A	115 volts AC, 50/60 Hz plug-in adaptor	
XP-1001	230 volts AC, 50/60 Hz plug-in adaptor	

Please note that the card versions of these products are compatible with the model 6000A card cage used with most FiberLink products and use 1 slot. Box versions require the XP-1000A power supply. Box versions can be adapted for use with the discontinued MCR-1000 rack by ordering the AP-1000 adapter plate. XA/RA-1900-7 are available with FCPC optical connectors at no additional cost. The XA-1903 is provided in a 19" rackmountable enclosure.

### Sales



T: 978-263-5775  
sales@artel.com  
customer@artel.com  
www.artel.com