



SB-36W and SB-11WE

Studio Boom Stands



Features

- Professional Boom Stand for Stage and Studio Use
- Caster-Equipped Model Offers Silent and Effortless Mobility
- Adjustable 6 or 2-lb. Counterweight Provides Precision and Stability
- Wearproof, Three-Piece Clutch Offers Secure, Fast, and Noise Free Adjustment
- Variable, Piston-Type Air Suspension System Ensures Microphone Protection
- Rugged Construction and Heavy-Duty Components Assure Long Service Life

General Description

SB-36W

These top-of-the-line boom stands feature a variable, piston-type air suspension system to ensure microphone protection. Model SB-36W is equipped with silent-motion, ball-bearing swivel casters of hard rubber for friction-free and vibration-absorbing mobility.

Two-piece horizontal boom assembly is $\frac{7}{16}$ " diameter cold rolled steel with a heavy-duty, die-cast, gyromatic swivel and an adjustable 6-lb. counterweight for precise and secure orientation. Tubing terminates with an adjustable mic holder swivel with standard $\frac{5}{8}$ "-27 thread to accept all microphones, holders, and adapters.

Vertical tube assembly is manufactured of 1- $\frac{1}{8}$ " and $\frac{7}{8}$ " chrome-plated cold rolled steel and includes the wearproof Atlas Sound grip-action clutch for easy adjustment and positive locking. Model includes wheels for a height span of 49" to 73". Triangular cast metal base with edge-concentrated weight distribution offers extra stability and is finished in ebony epoxy with a chrome shell.

SB-11WE

Economical studio boom is especially suited for small studio/broadcast applications and for stage miking of drums and percussion instruments. Unit features a 60" long, two-piece horizontal boom assembly constructed of stell tubing. Boom includes a Performer Series swivel clamp and an adjustable 2-lb. counterweight for effortless boom arm orientation. Tubing also incorporates a 90° angled end for optimum microphone positioning and terminates in the standard $\frac{5}{8}$ "-27 thread to accept all microphones, holders, and adapters.

Vertical tube assembly is 1- $\frac{1}{8}$ " and $\frac{7}{8}$ " diameter cold rolled steel with an adjustable height span of 43" to 68". Tubing features the wearproof Atlas Sound grip action clutch for positive locking control. Triangular die-cast base with edge concentrated weight distribution offers extra stability and is equipped with three, hard rubber swivel casters for effortless and silent mobility. Entire assembly is finished in non-reflective ebony epoxy.

Specifications

	SB-36W	SB-11WE
Tube Style	Two Section	Two Section
Stand Height	49"-73" 1245-1854mm	43"-68" 1219-1829mm
Boom Length	62" (1575mm)	60" (1524mm)
Counterweight	Adj. 6 lbs Adj. 2.75 kg	Adj. 2 lbs. Adj. 0.9 kg
Triangular Base	21" (533mm)*	21" (533mm)*
Stability Factor**	1890 I.S.I.	1610 I.S.I.
Base Finish	Ebony with Chrome Shell	Ebony
Tube Finish	Chrome	Ebony
Weight	40 lbs. (18 kg)	26 lbs. (11.8 kg)

* Dimension includes wheels. Triangular cast base is 15"

** Stability Index Factor (I.S.I.) evaluates the ability of a stand/boom assembly to remain at rest when acted upon by an outside force.

Application

This Atlas Sound professional quality boom stand incorporates the functional features and service reliability desired by performers and musicians, as well as broadcast/recording studios, theaters, and performance centers. All models are designed to meet the varying operational requirements of daily recording applications by combining maximum height and boom articulation ranges with increased mobility and dependable performance.

SB-36W Assembly Instructions

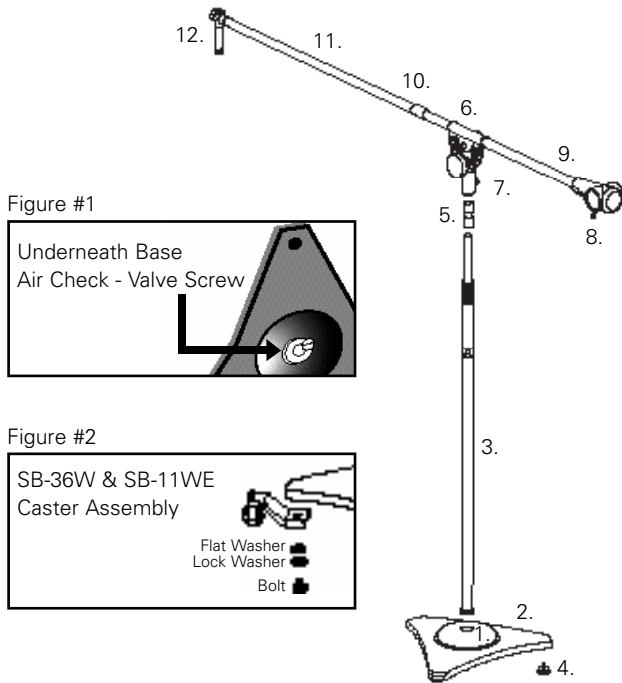

- A. Remove the chrome plated decorative shell #1 from the underside of the base casting #2. Discard the rubber "O" shipping ring. DO NOT adjust the check valve screw on the base until the upright tube is securely in position (See Figure 1). Place the chrome shell into position on top of the base.
- B. Thread the upright tube assembly #3 securely into the base to avoid air leakage. Faulty operation of the air check valve device on the underside of the base will be noticed if the upright tube is not installed tightly.
- C. Loosen or tighten the air check valve screw until the desired microphone stand tube assembly is achieved (See Figure 1).
- D. Attach three swivel casters onto the base using the lock washers, flat washers and bolts provided (See Figure #2).
- E. Thread swivel adapter #5 on top of the installed upright $\frac{7}{8}$ " tube assembly. Next, install the swivel assembly #6 on top of the adapter. Tighten swivel assembly screw #7.
- F. Install counterweight #8 on unthreaded end of $\frac{7}{8}$ " boom tube #9, then insert threaded end through swivel assembly and attach coupler #10.

- G. Thread remaining boom tube #11 into the coupler. Next, thread the hang straight swivel #12 onto the end of the boom assembly.
- H. Tighten all hardware and tubes securely.
- I. Attach desired microphone to the threaded hang straight swivel on the end of the boom.

SB-11WE Assembly Instructions

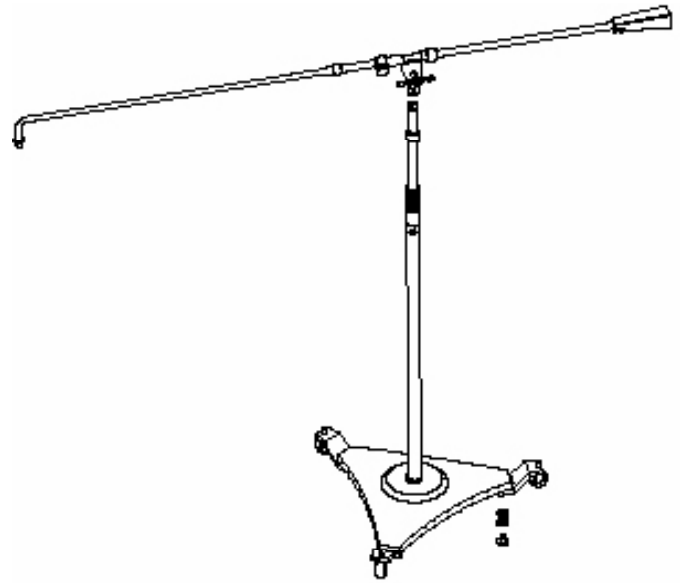

- A. Attach the three swivel casters onto the base using the lock washers, flat washers, and bolts provided.
- B. Thread upright tube assembly #3 securely into base #2. Use care to thread the tube perpendicular to the base to avoid stripping the threads.
- C. Thread swivel assembly #4 onto the top of the upright tube assembly.
- D. Place the straight boom tube #5, that contains the counterweight, through the swivel assembly. Next, thread the straight boom tube into the flared female end of the remaining boom tube #6.
- E. Tighten all hardware and tubes securely.
- F. Attach desired microphone to threaded, angled end of the boom.