

9242 » ANALOG AUDIO DISTRIBUTION AMPLIFIER WITH REMOTE GAIN CONTROL

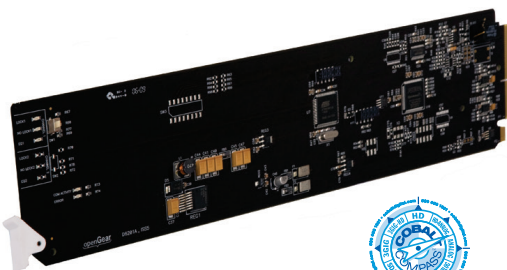

The 9242 Analog Audio Distribution Amplifier with Remote Gain Control is a broadcast-quality balanced analog audio DA with stereo 2x4, mono 1x8, and stereo sum L+R x 8 selectable output modes. Unlike most analog audio DAs, the 9242 electronic attenuators allow overall gain (stereo ganged) and per-channel trim (offset) via DashBoard™ remote control.

The space-saving design and very low power consumption of the 9242 provides for high density, allowing two cards to be collocated in adjacent slots and served by a single, standard-width “split” rear module.

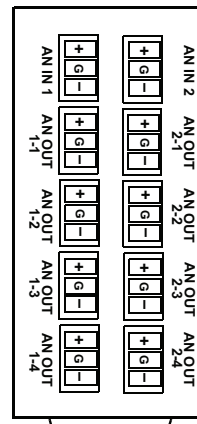

Note: + / G / - orientation on connectors varies from that on other Cobalt products. Make certain hookup is as shown here.

RM20-9242-B

» FEATURES

Full remote control of operating mode and gain control

Multiple modes – stereo 2x4, mono 1x8, and stereo sum L+R x 8 outputs

Full broadcast-grade balanced signal capability with 27.5 dBu maximum input level support. Low-impedance outputs.

Selectable card switch control or DashBoard™ remote control (usable with DashBoard™ and Cobalt OGCP-9000 remote control panels)

Five year warranty

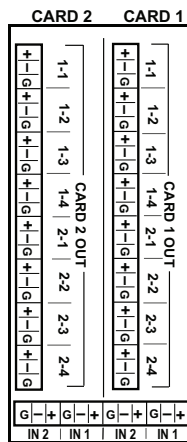
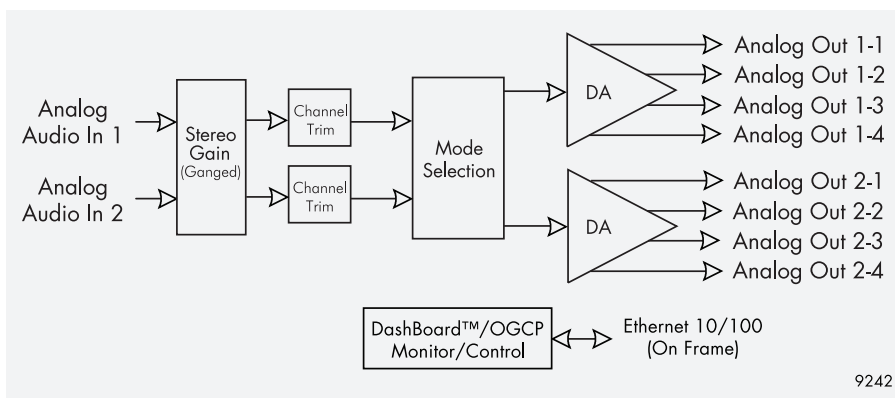

Note: Outputs 2-1 thru 2-4 are outputs 1-5 thru 1-8 when card used in mono DA or mono mix DA mode.

RM20-9242-D/S

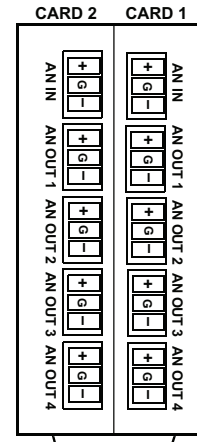

Note: + / G / - orientation on connectors varies from that on other Cobalt products. Make certain hookup is as shown here.

RM20-9242-C/S



» SPECIFICATIONS

Electrical

Power: < 5 Watts

Analog Audio Input

Number of Inputs: Two, balanced
 Impedance: > 20 k , balanced
 Maximum Input Level: +27.5 dBu
 Connector Type: WECCO® removable modular

Performance

Gain: -15 dB to +15 dB
 Frequency Response: 20 – 20 kHz ±0.1 dB
 Noise: < -85 dBu, 10 – 22 kHz at unity gain
 Harmonic Distortion: < 0.01%

Analog Audio Outputs

Number of Outputs: Eight, balanced; available as stereo 2x4, mono 1x8, and stereo sum L+R x 8 outputs
 Impedance: 60 , balanced
 Output Isolation: > 60 dB
 Connector Type: WECCO® removable modular

» ORDERING INFORMATION

9242 Analog Audio Distribution Amplifier with Remote Gain Control

RM20-9242-B 20-Slot Frame Rear I/O Module (Standard Width) 2 Balanced Analog Audio In, 8 Balanced Analog Audio Out

RM20-9242-C/S 20-Slot Frame Rear I/O Module (Split) 1x4 Balanced Analog Audio I/O (per card)

RM20-9242-D/S 20-Slot Frame Rear I/O Module (Split) Dual 1x4 Balanced Analog Audio I/O (per card)