

9433-EMDE-ADDA-OE • 3G/HD/SD-SDI Fiber-Optic OE Receiver with 16-Channel AES / 8-Channel Analog Audio Embed / De-Embed

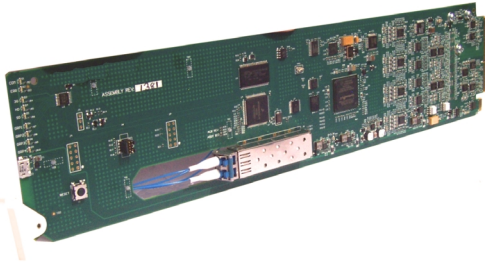

The Cobalt® 9433-EMDE-ADDA-OE 3G/HD/SD-SDI Fiber-Optic OE Receiver with 16-Channel AES / 8-Channel Analog Audio Embed / De-Embed offers full-flexibility AES and analog audio embedding/de-embedding with the built-in versatility of both coaxial and fiber SDI inputs in a basic, economical, high-efficiency openGear® card. More than only a basic embedder/de-embedder, the 9433-EMDE-ADDA-OE offers the flexibility of fiber to-SDI OE receive as well as providing fully flexible AES and analog audio embedding/de-embedding.

The 9433-EMDE-ADDA-OE provides full 16-channel embed / de-embed between AES, 8-channel analog audio, and all four groups of embedded audio. Audio embed adaptive SRC allows asynchronous 48 kHz AES audio to automatically sync with program video 48 kHz timing for glitch-free embedding. Individual, per-pair SRC auto-detects and disables SRC when a Dolby pair is detected on an input pair. Analog embed/de-embed conforms with professional balanced audio at 0 dBFS to pro 24 dBu levels using full 24-bit conversion. Fully error-free pathological pattern operation is fully compatible with professional fiber video interfaces. Full audio crosspoint allows per-channel gain and routing controls, as well as built-in tone generators.

Preset save/load allows saving custom card settings while allowing one-button revert to factory settings. Full user DashBoard™ or Remote Control Panel remote control allows full status and control access locally or across a standard Ethernet network.

FEATURES

OE fiber receiver with fiber and coax as inputs

16-channel AES support and 8-channel analog audio support in one card. Individual per-pair embedding or de-embedding. Provides four-group SDI embed/de-embed and cross-conversions between analog and AES discrete audio.

DashBoard™ status display, audio meters, tone generators. GUI audio meters provide ready assessment of content presence and line-up.

Audio embed adaptive SRC allows asynchronous 48 kHz AES audio to automatically sync with video 48 kHz timing for glitch-free embedding. Individual, per-pair SRC auto-detects and disables SRC when a Dolby pair is detected on an input pair.

Low-power/high-density design – less than 18 Watts per card

Option +DT User COM Data Insert/Extract Software Option allows serial data insert/extract over SDI (User DID/SDID access)

Remote control/monitoring via DashBoard™ software or OGCP-9000 remote control panels

Five year warranty

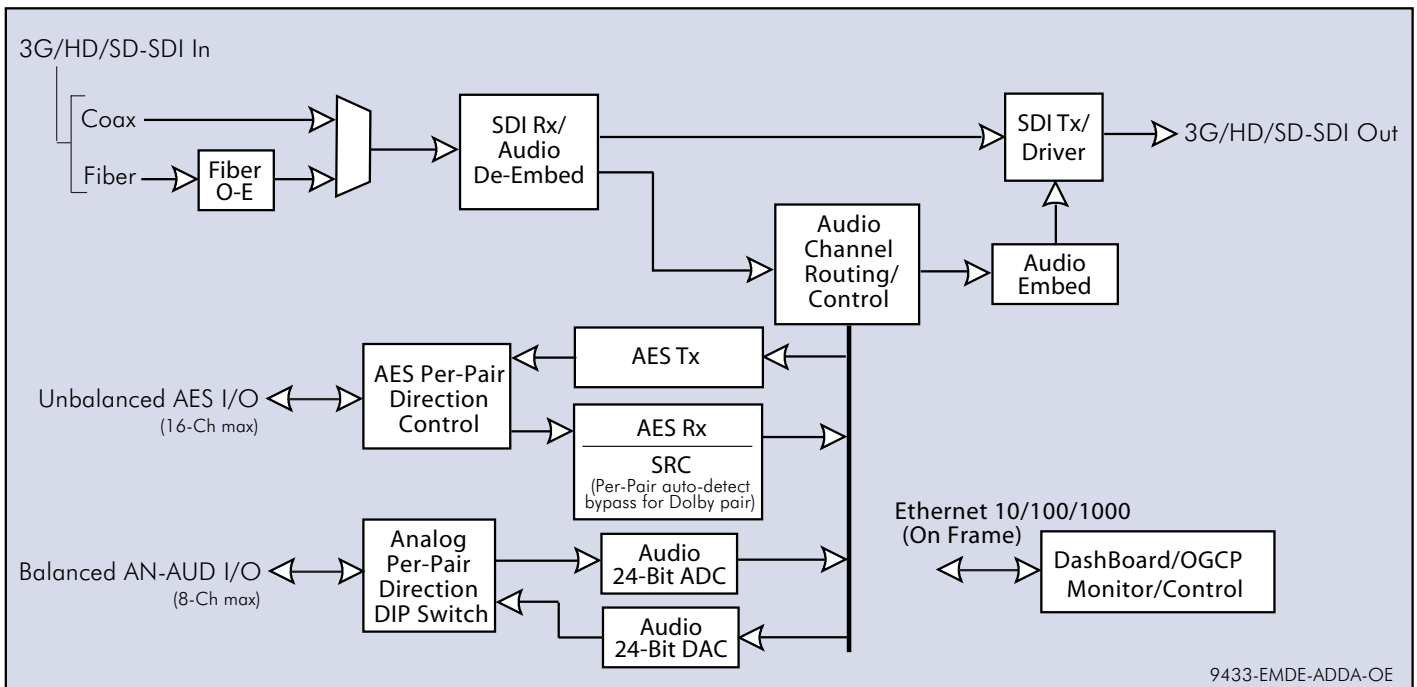

9433-EMDE-ADDA-OE • 3G/HD/SD-SDI Fiber-Optic OE Receiver with 16-Channel AES / 8-Channel Analog Audio Embed / De-Embed

SPECIFICATIONS

Note: Inputs/outputs are a function in some cases of rear I/O module used.

Power

<18 Watts

SDI/Fiber Inputs/Outputs

(1) 75Ω BNC inputs

(1) 75Ω BNC output

SDI Receive Cable Length (1694A): 120m/180m/360m (3G/HD/SD)

SDI Return Loss: >15 dB up to 1.485 GHz; >10 dB up to 2.970 GHz

Note: SDI Return loss and receive cable length are affected by rear I/O module used. Specifications represent typical performance.

Alignment Jitter: 3G/HD/SD: < 0.3/0.2/0.2 UI

Timing Jitter: 3G/HD/SD: < 2.0/1.0/0.2 UI

(1) Fiber input; LC connector

Receive Sensitivity: -23 dBm; 1260 to 1620 nm

SDI Formats Supported: SMPTE 259M, SMPTE 292M, SMPTE 424M

Audio Conversion Format

48 kHz sampling, 24-bit. Auto-SRC bypass for Dolby inputs. Analog audio I/O conforms to +24 dBu <=> 0 dBFS.

Analog Audio Specifications

Input Impedance: >10 kΩ

Reference Level: -20 dBFS

Nominal Level: +4 dBu

Input Clip Level: +24 dBu (0 dBFS)

Freq. Response: ±0.2 dB (20 Hz to 20 kHz)

SNR: 115 dB (A weighted)

THD+N: -96 dB (20 Hz to 10 kHz)

Crosstalk: -106 dB (20 Hz to 20 kHz)

Output Impedance: < 50 Ω

Max. Output Level: +24 dBu (0 dBFS)

Discrete Audio Input/Output

(8) Unbalanced AES (AES-3id; 75Ω) with per-pair port direction controls

(8) Balanced Analog Audio with per-pair port direction controls

ORDERING INFORMATION

9433-EMDE-ADDA-OE 3G/HD/SD-SDI Fiber-Optic OE Receiver with 16-Channel AES / 8-Channel Analog Audio Embed / De-Embed

RM20-9433EMDE-OE-C-DIN 20-Slot Frame Rear I/O Module (Standard Width) (1) 3G/HD/SD-SDI Input BNC, (1) 3G/HD/SD-SDI Output BNC, (1) Fiber Input (LC connector), (8) Balanced Analog Audio I/O, (8) Unbalanced AES I/O (coaxial; DIN 1.0/2.3)

RM20-9433EMDE-OE-C-HDBNC 20-Slot Frame Rear I/O Module (Standard Width) (1) 3G/HD/SD-SDI Input BNC, (1) 3G/HD/SD-SDI Output BNC, (1) Fiber Input (LC connector), (8) Balanced Analog Audio I/O, (8) Unbalanced AES I/O (coaxial; HD-BNC)

RM20-9433EMDE-OE-D 20-Slot Frame Rear I/O Module (Standard Width) (1) 3G/HD/SD-SDI Input BNC, (1) 3G/HD/SD-SDI Output BNC, (1) Fiber Input, (8) Balanced Analog Audio I/O, Unbalanced AES I/O/COMM (via HD-15 connector)

+DT User COM Data Insert/Extract Software Option

Note: COMM port setup and usage available only with option +DT.

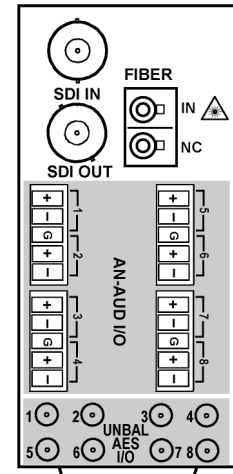

RM20-9433EMDE-OE-C-DIN
RM20-9433EMDE-OE-C-HDBNC

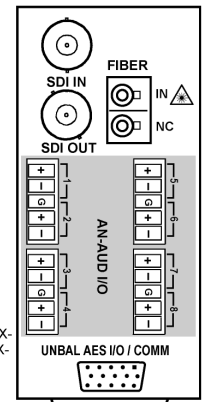

1 - RS422 RX+
2 - RS422 TX+
5 - GND
6 - RS232 RX / RS422 RX-
7 - RS232 TX / RS422 TX-
14 - AES I/O 1
15 - AES I/O 2
Other conns NC

RM20-9433EMDE-OE-D