

Studio Electrol®

Automatic Electric Projection Screen Model

DA-LITE
A brand of Legend

SUGGESTED SPECIFICATIONS: _____ projection screen(s), _____ (H) x _____ (W), electrically operated 120 volt (60Hz), not more than 3.4 amp. Shall have specially designed motor mounted inside the roller, to be two wire with ground, quick reversal type, oiled for life, with automatic thermal overload cutout, integral gears, capacitor and an electric brake to prevent coasting. To have preset but adjustable limit switches to automatically stop picture surface in the "up" and "down" positions. Junction box shall be internally integrated into the housing making it possible to install the housing and wire to the building's electrical system during

construction. Rigid metal roller, to be at least 7/8" in diameter. The motorized fabric and roller assembly to be installed in the case at the factory. Screen to be designed for left hand motor installation. Screen fabric to be flame retardant and mildew resistant. Bottom of fabric shall be fitted with a metal slat covering. Heavy duty plastic caps shall protect the ends of the metal slat. Case housing to be made of structural steel tubing with aluminum metal coverings on top, aluminum profiles on rear and front and two extruded aluminum side coverings. The bottom of the casing is standard open. To be complete with a three-position radio remote control.



HDTV (16:9, 1.78:1) Format Dimensions

Viewing Area (H x W)		Nominal Diagonal		Overall Length of Case*		Approx. Hang Wt.		Approx. Ship. Wt.	
In.	Cm	In.	Cm	In.	Cm	Lbs.	Kg	Lbs.	Kg
176" x 312"	447 x 792	359"	912	322¾"	820	720	326.6	1195	542.0
189" x 336"	480 x 853	385"	978	346¾"	881	742	336.6	1269	575.6
203" x 360"	516 x 914	414"	1052	370¾"	942	777	352.4	1338	606.9
216" x 384"	549 x 975	440"	1118	394¾"	1003	788	357.4	1442	654.1

Cinemascope (21:9, 2.35:1) Format Dimensions

Viewing Area (H x W)		Nominal Diagonal		Overall Length of Case*		Approx. Hang Wt.		Approx. Ship. Wt.	
In.	Cm	In.	Cm	In.	Cm	Lbs.	Kg	Lbs.	Kg
133" x 312"	338 x 792	340"	864	322¾"	820	705	319.8	1186	537.9
143" x 336"	363 x 853	365"	927	346¾"	881	740	335.7	1254	568.8
153" x 360"	389 x 914	391"	993	370¾"	942	755	342.5	1312	585.1
163" x 384"	414 x 975	416"	1057	394¾"	1003	777	352.4	1416	642.3

Video (NTSC 4:3, 1.33:1) Format Dimensions

Viewing Area (H x W)		Nominal Diagonal		Overall Length of Case*		Approx. Hang Wt.		Approx. Ship. Wt.	
In.	Cm	In.	Cm	In.	Cm	Lbs.	Kg	Lbs.	Kg
234" x 312"	594 x 792	390"	991	322¾"	820	731	331.6	1203	545.7

*Case length does not include flange

PRODUCT NOTES

- Horizontal seam required when height exceeds 75".
- Overall case length dimensions +/- ¼" (6 mm).
- Detail dimensional drawings, wiring diagrams and installation instructions available upon request.
- Adjustable mounting brackets for ceiling installation standard
- Adjustable mounting brackets for wall installation can be substituted for ceiling brackets
- Specifications subject to change without notice.
- Custom formats and sizes available upon request.

WHEN ORDERING, MARK APPROPRIATE SELECTIONS:

1. Select size from charts on the other side.
2. Select viewing surface (All Da-Lite surfaces are GREENGUARD GOLD Certified.):

<input type="checkbox"/> Matte White	<input type="checkbox"/> Perforated Matte White
--------------------------------------	---
3. Options:

<input type="checkbox"/> Extra Drop available to lower picture area more than normal. Specify total white drop at top _____ or at bottom _____. 19'-8" maximum total surface height including picture area	<input type="checkbox"/> Wall mount brackets (ceiling mount standard)
	<input type="checkbox"/> Black case (grey standard)
	<input type="checkbox"/> White case (grey standard)

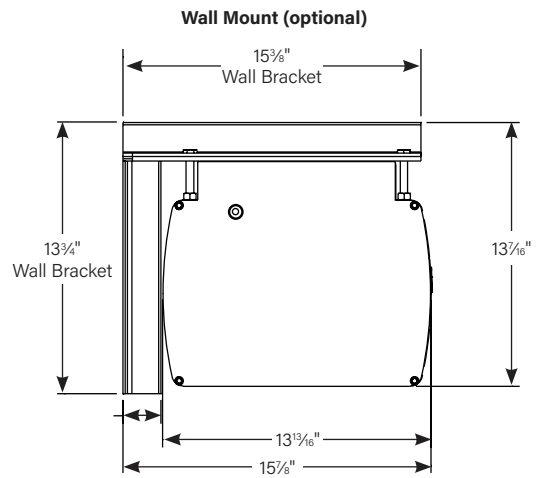
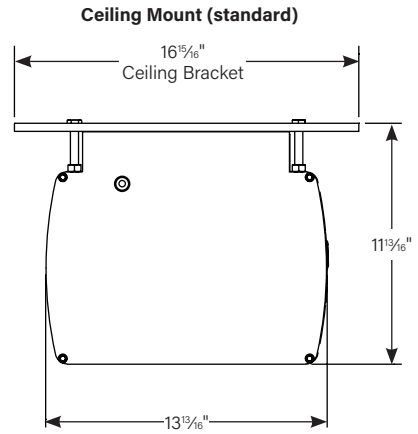
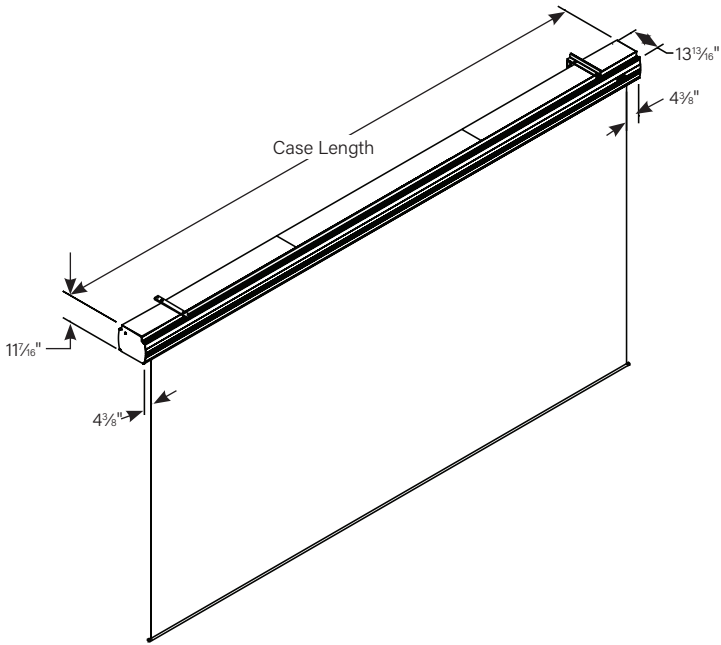

Project Name: _____

Architect: _____

Contractor: _____ Phone: _____

Reseller: _____ Phone: _____

DA-LITE
A brand of **legrand**

LEGRAND | AV COMMERCIAL BRANDS
C2G | Chief | Da-Lite | Luxul | Middle Atlantic | Vaddio | Wiremold

FOR YOUR IMAGE | legrandav.com

USA 866.977.3901 av.da-lite.support@legrand.com CANADA 877.345.4329 av.da-lite.support@legrand.com
EMEA +31 495 580 840 av.emea.sales@legrand.com APAC +852 2145 4099 av.asia.sales@legrand.com

©2023 Legrand AV Inc. DL-0239 Rev 1 6/23 Da-Lite is a registered trademark of Legrand AV Inc. All other brand names or marks are used for identification purposes and are trademarks of their respective owners. All patents are protected under existing designations. Other patents pending.