

Model C

Spring Roller Type Screen



SPECIFICATION DATA

SUGGESTED SPECIFICATIONS: _____ projection screen(s), _____(H) x _____(W), wall or ceiling mounting type. To have black masking borders standard on flame retardant and mildew resistant fiberglass fabric, mounted on a ball bearing rigid steel spring roller. Fabric to be permanently attached to roller. To have powder coated white 21-gauge steel case with flat back design. To have heavy-duty end caps concealing roller

ends with steel inner plates to support roller and provide added case strength. End caps shall form sturdy brackets for wall or ceiling installations. Bottom of screen shall be formed into pocket holding tubular metal slat. A steel pull bail shall be attached to the slat. The ends of the slat shall be protected by heavy duty plastic caps. Bumper stops shall be built into case to prevent slat wedging inside case. A 6' pull cord with plastic knob is included.

HDTV (16:9) Format Dimensions

Viewing Area (H x W)		Nominal Diagonal		A - Overall Length of Case		B - Between Hanger Eyes		Approx. Ship. Wt.	
In.	Cm	In.	Cm	In.	Cm	In.	Cm	Lbs.	Kg
45" x 80"	114 x 203	92"	234	87 ³ / ₁₆ "	222	85 ¹³ / ₁₆ "	218	47	21.3
52" x 92"	132 x 234	106"	269	99 ³ / ₁₆ "	252	97 ¹³ / ₁₆ "	248	52	23.6
54" x 96"	137 x 244	110"	279	103 ³ / ₁₆ "	262	101 ¹³ / ₁₆ "	258	54	24.5
58" x 104"	147 x 264	119"	302	111 ¹ / ₁₆ "	283	109 ⁹ / ₁₆ "	279	60	27.2
65" x 116"	165 x 295	133"	338	123 ³ / ₁₆ "	313	121 ¹³ / ₁₆ "	309	69	31.3
78" x 139"	198 x 353	159"	404	147 ⁷ / ₁₆ "	374	145 ⁹ / ₁₆ "	370	79	35.8

(16:10) Wide Format Dimensions

Viewing Area (H x W)		Nominal Diagonal		A - Overall Length of Case		B - Between Hanger Eyes		Approx. Ship. Wt.	
In.	Cm	In.	Cm	In.	Cm	In.	Cm	Lbs.	Kg
50" x 80"	127 x 203	94"	239	87 ³ / ₁₆ "	222	85 ¹³ / ₁₆ "	218	47	21.3
57 ¹ / ₂ " x 92"	146 x 234	109"	277	99 ³ / ₁₆ "	252	97 ¹³ / ₁₆ "	248	52	23.6
60" x 96"	152 x 244	113"	287	103 ³ / ₁₆ "	262	101 ¹³ / ₁₆ "	258	54	24.5
65" x 104"	165 x 264	123"	312	111 ¹ / ₁₆ "	283	109 ⁹ / ₁₆ "	279	60	27.2
69" x 110"	175 x 279	130"	330	117 ³ / ₁₆ "	298	115 ¹³ / ₁₆ "	294	62	28.1
72 ¹ / ₂ " x 116"	184 x 295	137"	348	123 ³ / ₁₆ "	313	121 ¹³ / ₁₆ "	309	69	31.3
87" x 139"	221 x 353	164"	417	147 ⁷ / ₁₆ "	374	145 ⁹ / ₁₆ "	370	79	35.8

Video (NTSC 4:3) Format Dimensions

Viewing Area (H x W)		Nominal Diagonal		A - Overall Length of Case		B - Between Hanger Eyes		Approx. Ship. Wt.	
In.	Cm	In.	Cm	In.	Cm	In.	Cm	Lbs.	Kg
43" x 57"	109 x 145	72"	183	63 ³ / ₈ "	160	61 ¹ / ₈ "	157	26	11.8
50" x 67"	127 x 170	84"	213	73 ³ / ₈ "	186	71 ¹ / ₈ "	182	31	14.1
60" x 80"	152 x 203	100"	254	87 ³ / ₁₆ "	222	85 ¹³ / ₁₆ "	218	47	21.3
69" x 92"	175 x 234	120"	305	99 ³ / ₁₆ "	252	97 ¹³ / ₁₆ "	248	52	23.6
87" x 116"	221 x 295	150"	381	123 ³ / ₁₆ "	313	121 ¹³ / ₁₆ "	309	69	31.3
105" x 140"	267 x 356	180"	457	147 ⁷ / ₁₆ "	374	145 ⁹ / ₁₆ "	368	79	35.8
120" x 160"	305 x 406	200"	508	167 ¹ / ₁₆ "	425	165 ¹³ / ₁₆ "	421	96	43.5

Square Format Dimensions

Sizes (H x W)		A - Overall Length of Case		B - Between Hanger Eyes		Approx. Ship. Wt.	
In.	Cm	In.	Cm	In.	Cm	Lbs.	Kg
60" x 60"	152 x 152	63 ³ / ₈ "	161	61 ¹ / ₈ "	157	26	11.8
70" x 70"	178 x 178	73 ³ / ₈ "	186	71 ¹ / ₈ "	182	31	14.1
72" x 72"	183 x 183	75 ¹ / ₈ "	191	73 ³ / ₈ "	187	33	15.0
84" x 84"	213 x 213	87 ³ / ₁₆ "	222	85 ¹³ / ₁₆ "	218	47	21.3
8' x 8'	244 x 244	99 ³ / ₁₆ "	252	97 ¹³ / ₁₆ "	248	52	23.6
9' x 9'	274 x 274	111 ¹ / ₁₆ "	283	109 ⁹ / ₁₆ "	279	60	27.2
10' x 10'	305 x 305	123 ³ / ₁₆ "	313	121 ¹³ / ₁₆ "	309	69	31.3
12' x 12'	366 x 366	147 ⁷ / ₁₆ "	374	145 ⁹ / ₁₆ "	370	85	38.6

PRODUCT NOTES

- **Matte White:** Horizontal seam required when both dimensions exceed 10'.
- **High Contrast Matte White and Video Spectra 1.5:** Available in sizes where both dimensions do not exceed 8'.
- Overall case length dimensions +/- 1/4".
- Detail dimensional drawings and installation instructions available upon request.
- Specifications subject to change without notice.
- Custom formats and sizes available upon request.
- **Optional Accessories:** to provide clearance: Furnish heavy extension wall brackets to mount screen 6" from wall. To provide for keystone elimination: Furnish heavy extension wall brackets to mount screen 10" or 14" from wall or furnish heavy adjustable extension wall brackets to mount screen 10", 14", 15 3/4", 18 1/4", 20" or 24" from wall.
- **NOTE:** Brackets also are used for mounting screen across a corner.

WHEN ORDERING, MARK APPROPRIATE SELECTIONS:

1. Select size from charts on the other side.
2. Select viewing surface (All Da-Lite surfaces are GREENGUARD GOLD Certified):
 - Matte White
 - High Contrast Matte White
 - Video Spectra 1.5
3. Optional accessories:
 - Extra Drop available to lower picture area more than normal. Specify total drop at top ____ (black or white) or at bottom ____ (black or white). 13' maximum total surface height including picture area.
 - No. 6 Wall Bracket - extends 6" non-adjustable extension brackets (140# per pair maximum) (black or white).
 - No. 11 Wall Bracket - 10" or 14" non-adjustable extension brackets (75# per pair maximum) (black or white).
 - No. 23 Adjustable Wall Bracket - extends 10", 14", 15 3/4", 18 1/4", 20" or 24" (75# per pair maximum) (black or white).
 - Pull Rod - 38".
 - No borders (Black masking borders standard)
 - CSR (Controlled Screen Return)
 - Floating Mounting Bracket (black or white). Recommended for drywall installations.
 - Ceiling Trim Kit.
 - Floor Model Available.
 - Floor Stand.
 - Carpeted Floor Model Available (black or gray).
 - Black case (white standard).

PRODUCT VIEW

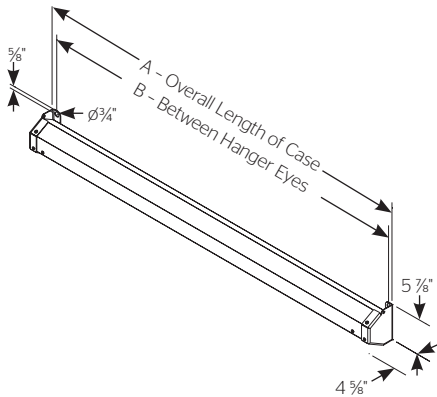

ACCESSORIES

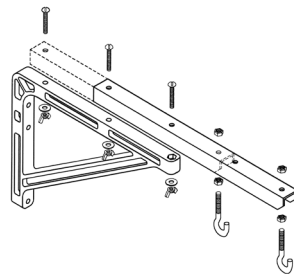

No. 23 Adjustable Wall Bracket
Screen can be extended 10", 14", 15 3/4", 18 1/4", 20" or 24" from wall by wing nut and bolt adjustment.

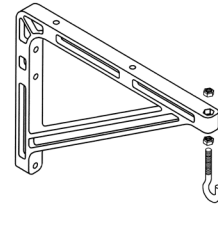

No. 11 Wall Bracket
Screen can be extended 10" or 14" from wall by changing position of bracket.

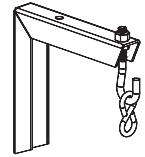

No. 6 Wall Bracket
Screen can be extended 6" from wall.

Extension Wall Brackets



A BRAND OF MILESTONE AV TECHNOLOGIES

www.milestone.com
 P 800.622.3737 / 574.267.8101
 F 877.325.4832 / 574.267.7804
 E info@da-lite.com

In British Columbia, Milestone AV Technologies ULC carries on business as MAVT Milestone AV Technologies ULC.

©2017 Milestone AV Technologies. DL-0226 (Rev. 5) 12.17.
 Da-Lite is a registered trademarks of Milestone AV Technologies. All other brand names or marks are used for identification purposes and are trademarks of their respective owners. All patents are protected under existing designations. Other patents pending.

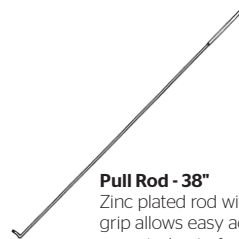

Pull Rod - 38"
Zinc plated rod with black plastic handle grip allows easy access to screen when mounted out of reach. Also can be used as a pointer.

Project Name: _____
 Architect: _____
 Contractor: _____ Phone: _____
 Reseller: _____ Phone: _____