

BrightEye 1

Analog/SD SDI to SD SDI/Optical Converter with TBC and Frame Sync

BrightEye 1 is a comprehensive solution to signal acquisition. With analog component, analog composite S-Video (Y/C), and SDI video inputs, it can take on any video source. The built-in time base corrector/frame synchronizer provides a rock steady output, even with marginal inputs. The reference input is used to genlock the converter output to house reference such as color black.

Front panel controls select input source, format and adjust video gain. Video levels can be adjusted through BrightEye Mac or PC software.

Simultaneous SD SDI (electrical) and optical outputs are provided, so you can deliver the signal just about anywhere. Both color bars and the SD SDI checkfield (pathological) test patterns are included to facilitate transmission path testing.

Features

- Use with cameras, satellite receivers and VHS decks
- Analog and SD SDI input
- SD SDI and optical output
- TBC and frame sync
- 12 bit processing
- Passes embedded audio

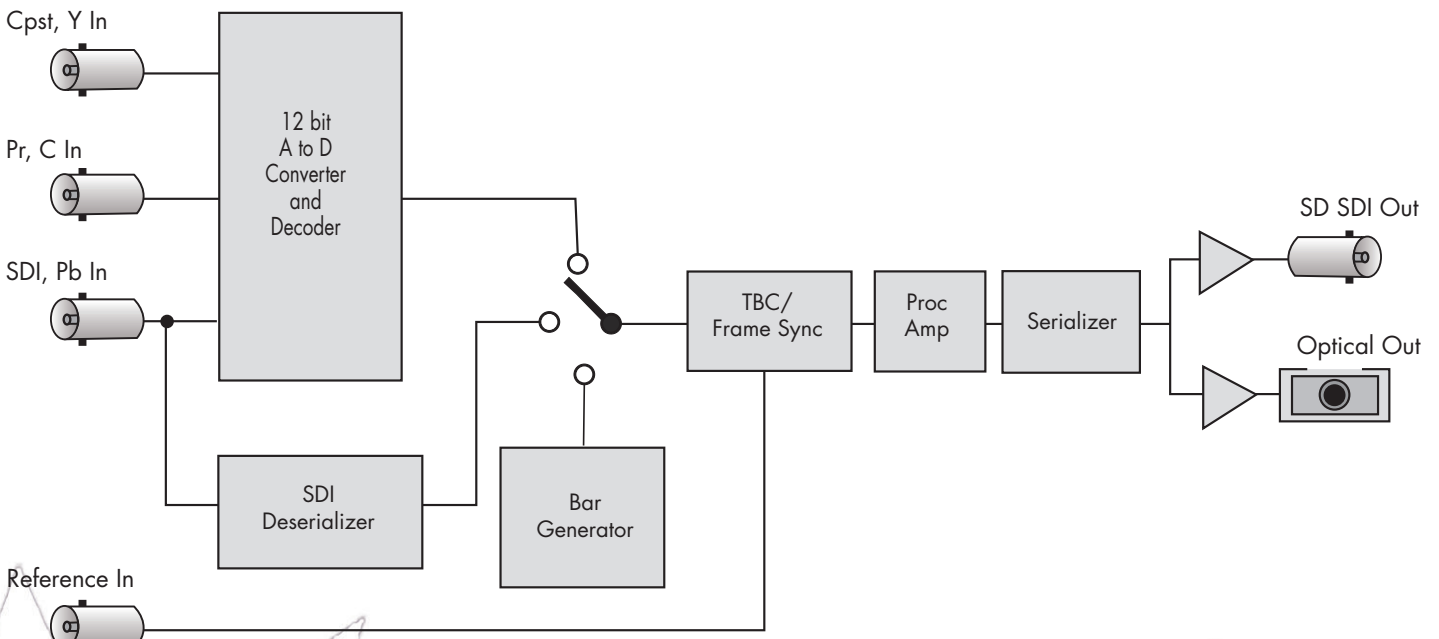

Analog/SD SDI to SD SDI/Optical Converter with TBC and Frame Sync

Serial Digital Input

Number	One
Signal Type	270 Mb/s SD Serial Digital (SMPTE 259M)
Impedance	75 Ω
Return Loss	>15 dB
Max Cable Length	300 meters
Automatic Input Cable Equalization	

Analog Input

Number	One
Type	Beta/SMPTE, Y, Pr, Pb NTSC, PAL Composite NTSC, PAL S-Video
Impedance	75 Ω
Return Loss	>40 dB
Input DC	+/-1 volt DC
Input Hum	<100 mV

Serial Digital Output

Number	One
Type	270 Mb/s SD Serial Digital (SMPTE 259M)
Delay	< 90 μ Sec
Impedance	75 Ω
Return Loss	>15 dB
Output DC	None (AC coupled)

Optical Output

Number	One
Type	270 Mb/s SD Serial Digital (SMPTE 259M) (Optical equivalent of 259M)
Wavelength	1310 nm (non-CWDM) (1550 non-CWDM by special order)
Power	-7 dBm
Maximum Cable Length	20 km (For greater distances, or higher power and larger loss budgets, please contact the factory)
Fiber Type	Single Mode Multi-mode compatible with attenuation at transmit end
Connector	SC

Analog to SDI Performance

Bit Resolution	12 bit input quantization 4 x oversampling
Signal to Noise	>62 dB, weighted
Frequency Response	
Composite and Y	\pm 0.1 dB, 0 to 5.5 MHz
Pr, Pb	\pm 0.1 dB, 0 to 2.75 MHz
Minimum Delay	90 μ Sec

Reference Input

Number	One
Type	1 V P-P Composite Video, PAL or NTSC
Impedance	75 Ω
Return Loss	>40 dB

General Specifications

Size	5.63" W x 0.8" H x 5.98" D (143 mm x 21 mm x 152 mm) including connectors and flange
Weight	14 oz
Power	12 volts, 7 watts (100-230 VAC modular power supply)
Temperature Range	0 to 40° C ambient (all specs met)
Relative Humidity	0 to 95%, non-condensing
Altitude	0 to 10,000 ft.