

BrightEye 20

Analog Audio/AES Embedder or Disembedder

BrightEye 20 is a versatile audio mux/demux. With SD SDI video I/O, and both analog and AES I/O, it is field configurable for embedding or disembedding.

When configured as a multiplexer, BrightEye 20 has one serial digital video input and two AES digital audio inputs. Alternately, the 4 channel analog audio input can be used. The audio is embedded into the digital video stream. The output is a serial digital video stream that contains the original video plus the two AES streams or four analog audio channels.

When configured as a demultiplexer, audio signals present in the incoming serial digital video signal are extracted and delivered simultaneously as two AES digital audio streams and as four analog audio channels.

Audio mixing, level adjustments, and channel shuffling can be applied to both the multiplexer and demultiplexer modes, and are accessed through BrightEye Mac or PC software. Audio group selection is also made through BrightEye Mac or PC software. A variety of audio connectors and adapters are available for integrating BrightEye 20 to any type of system.

Features

- **Audio embedder or disembedder**
- **Analog and digital inputs**
- **Analog and digital outputs**
- **Use in desktop and broadcast applications**



Video Input

Number	One
Signal Type	270 Mb/s SD Serial Digital (SMPTE 259M)
Impedance	75 Ω
Return Loss	>15 dB
Max Cable Length	300 meters
Automatic Input Cable Equalization	

Video Output

Number	One
Signal Type	270 Mb/s SD Serial Digital (SMPTE 259M)
Delay	< 1 μ Sec to SDI path
Impedance	75 Ω
Return Loss	>15 dB
Output DC	None (AC coupled)

Analog Audio Inputs

Number	Four (selectable as inputs or outputs)
Type	Balanced
Impedance	>15K Ω
Maximum Input Level	24 dBu
CMRR	>60 dB, 20 Hz to 10 KHz
Quantization	24 bits, 128 x oversampled
Sample Rate	48 KHz
Reference Level	-10 dBu or +4 dBu
Frequency Response	\pm 0.1 dB, 20 Hz to 20 KHz
Crosstalk	<106 dB
Dynamic Range	>106 dB

AES/EBU Digital Inputs

Number	Two (total of four channels) (selectable as inputs or outputs)
Type	AES3id
Connector	Coaxial, 75 Ω
Bit Depth	20 and 24 Bit
Sample Rate	30 KHz to 96 KHz (Sample Rate Converted internally to 48 KHz)
Reference Level	-18 or -20 dBFS (selectable)
AC-3, Dolby-E	Supported when inputs are synchronous

Analog Audio Outputs

Number	Four (selectable as inputs or outputs)
Type	Balanced, transformerless
Delay	< 250 μ Sec to audio I/O
Impedance	30 Ω
Maximum Output Level	24 dBu
Resolution	24 bits, 128 x oversampled
Reference Level	-10 dBu or +4 dBu
Frequency Response	\pm 0.1 dB, 20 Hz to 20 KHz
Crosstalk	<106 dB
Dynamic Range	>106 dB

AES/EBU Digital Outputs

Number	Two (total of four channels) (selectable as inputs or outputs)
Type	AES3id
Connector	Coaxial, 75 Ω
Bit Depth	24 Bit
Sample Rate	48 KHz Synchronous to video output
Reference Level	-18 or -20 dBFS (selectable)

General Specifications

Size	5.63" W x 0.8" H x 5.98" D (143 mm x 21 mm x 152 mm) including connectors and flange
Weight	1 lb
Power	12 volts, 7 watts (100-230 VAC modular power supply)
Temperature Range	0 to 40° C ambient (all specs met)
Relative Humidity	0 to 95%, non-condensing
Altitude	0 to 10,000 ft.

BrightEye 20 Block Diagrams on following pages

BrightEye 20

Analog Audio/AES Embedder or Disembedder

AES Mux (Cascade or Replace) Mode

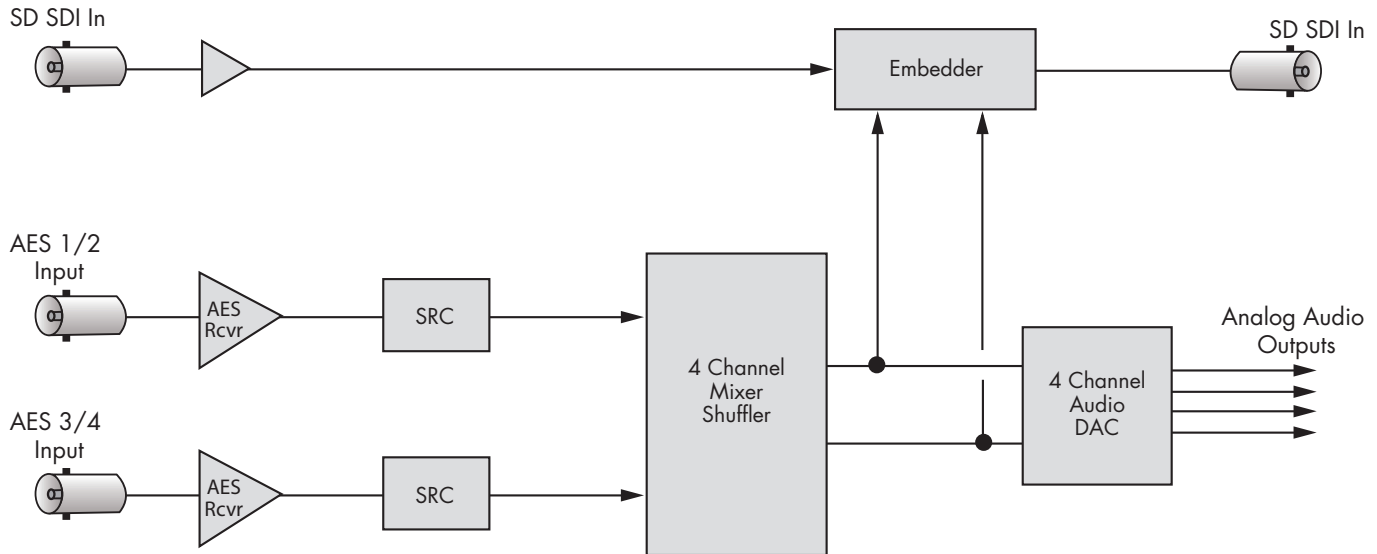

Analog Mux (Cascade or Replace) Mode

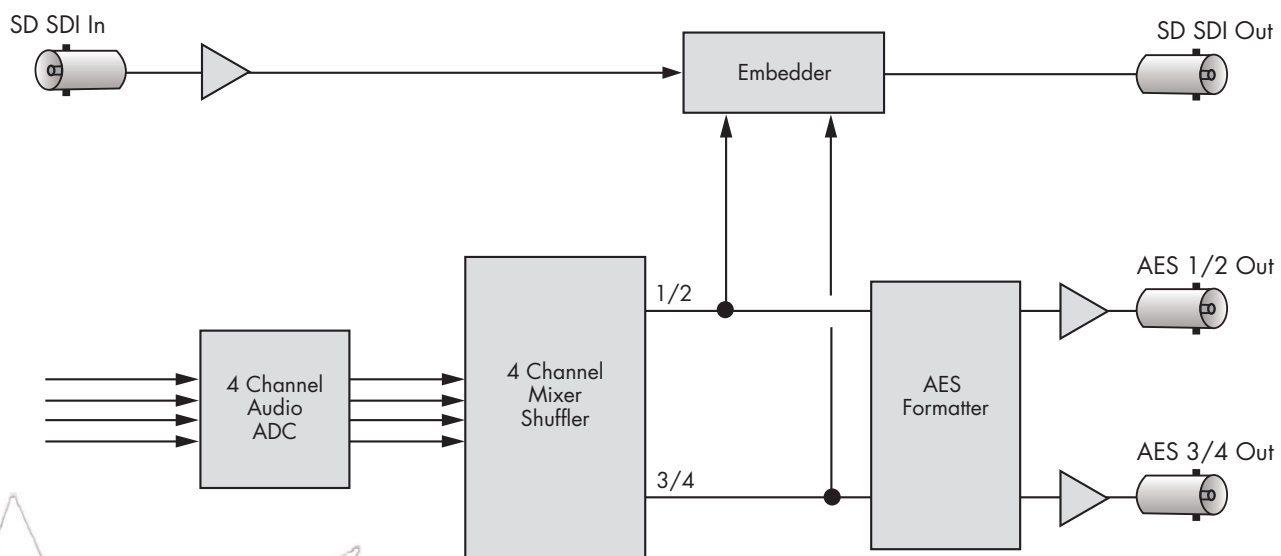

Demux Mode

