

DASH NO. M CODE MADE FROM

S-D

KTH-2025

REVISIONS

ISSUE	CHANGES
2	CN 27545 C SD 8 NOV 85

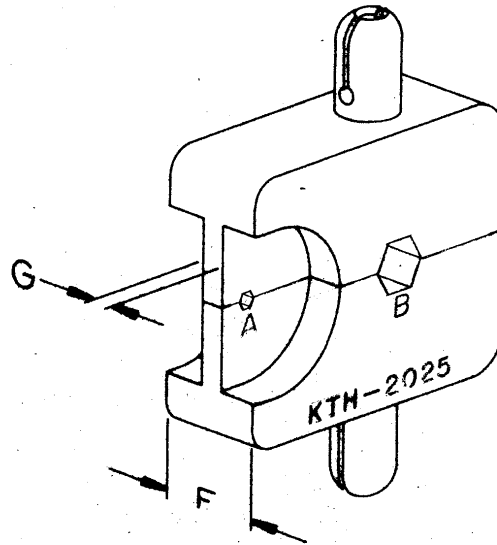

S-D

SCALE: 2:1

USED ON:

REF:

CRIMP DIE

DRAWN M.D. DATE 2BAG/BI
APPR. DATE

KINGS
ELECTRONICS CO. INC.
TUCKAHOE, NEW YORK 10707

KTH-2025

NOTES:

1. FOR USE WITH RG-122, 180, 195, AMPHENOL 21-597 & RACHEM 09-020 CABLE.

HEX SIZES (ACROSS FLATS)				DIE WIDTH		DIE WIDTH		
A	B	C	D	F	G	H	I	
.042	.178	—	—	—	.400	.080	—	—

UNLESS OTHERWISE SPECIFIED:

1. TOLERANCES: FRACTIONS & 2 PLACE DECIMALS $\pm .010$
3 PLACE DECIMALS $\pm .004$ ANGLES $\pm 0^{\circ}30'$
 2. REMOVE ALL BURRS, BREAK SHARP EDGES .005 MAX.
 3. NO FILLETS PERMITTED.
 4. SURFACE ROUGHNESS 63 MICROINCHES RMS MAX.
 5. ALL DIMENSIONS PRIOR TO PLATING.
 6. ALL PLATING IN ACCORDANCE WITH KER 10004.
- T. I. R. CONCENTRICITY OF ANY 2 DIAMETERS MAY NOT EXCEED HALF THE SUM OF THEIR TOLERANCES.