

INSTRUCTION SHEET

SSL/SS

SLIDING SHELF

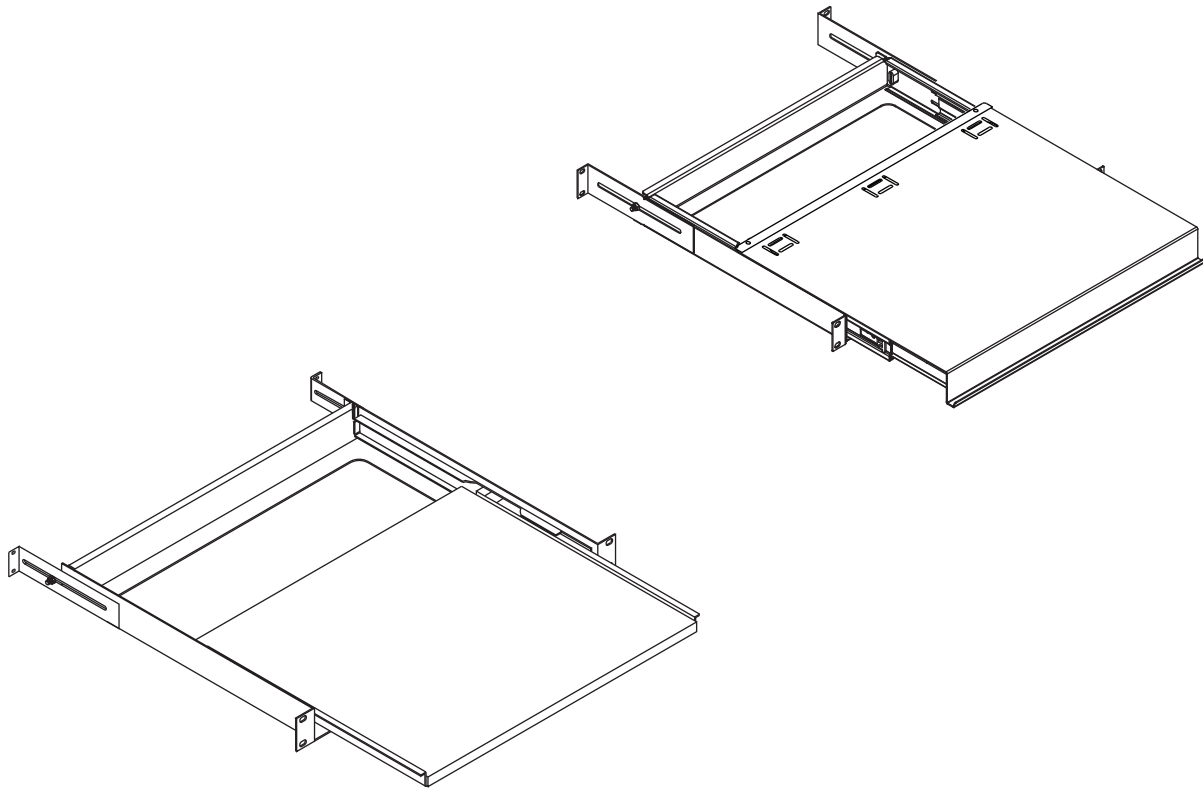

THANK YOU

Thank you for purchasing the SS/SSL Sliding Shelf. Please read these instructions thoroughly before installing this product.

PRODUCT FEATURES

- Shelf slides out for easy access to the rear of equipment or to create a writing surface
- Telescopic rear support allows both shelves to be mounted to any rack
- Large shelf area can accommodate a wide variety of equipment

PARTS LIST

SLIDING SHELF (SS SHOWN)

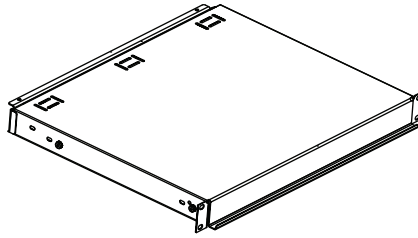

QTY	PART
1	A

PSSRB1

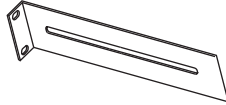

QTY	PART
2	B

8-32 x 1/2 PANHEAD SCREW



QTY	PART
2	C

#10X5/8
WOOD SCREW



QTY	PART
2	E

7/8" HOOK AND LOOP FASTENERS



QTY	PART
2	D

8-32
STAR NUT



QTY	PART
2	F

OPERATION

SSL

CAUTION: DO NOT PULL OUT THE SHELF TOO FAR, IT MAY BECOME DETACHED.

- To extend the shelf, grab the front edge of the shelf and gently pull forward until the rollers seat in locking dimples.

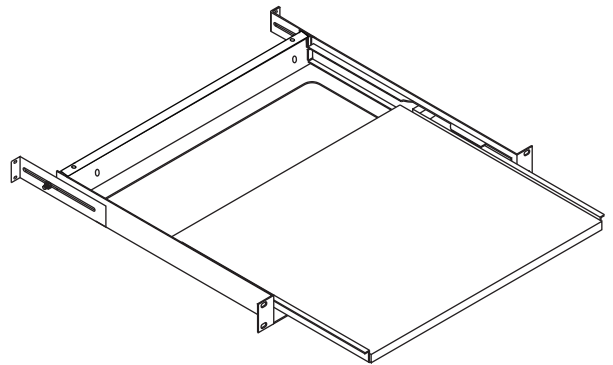

SSL

SS

- To extend the shelf, pull forward by grasping the flange on the front of the shelf. The shelf will lock when fully extended.

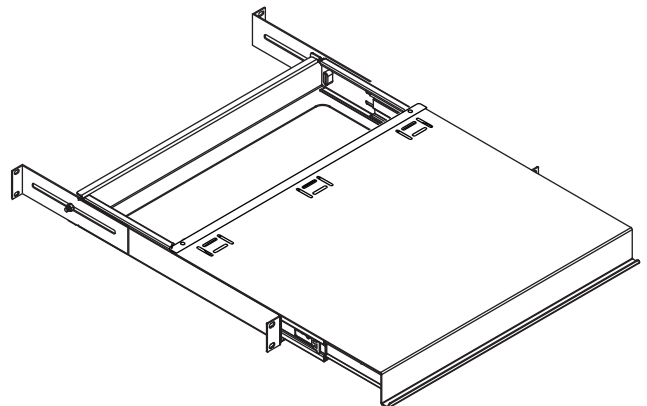

SS

INSTALLATION

WOOD RACK INSTALLATION (Without Rear Rail)

- Extend the rear hanging brackets until they meet the sides of the rack. **(FIGURE A)**
- Level the shelf from front to back. Secure the brackets to the sides with supplied wood screws. Tighten the wing-nuts on the bracket. **(FIGURE A)**

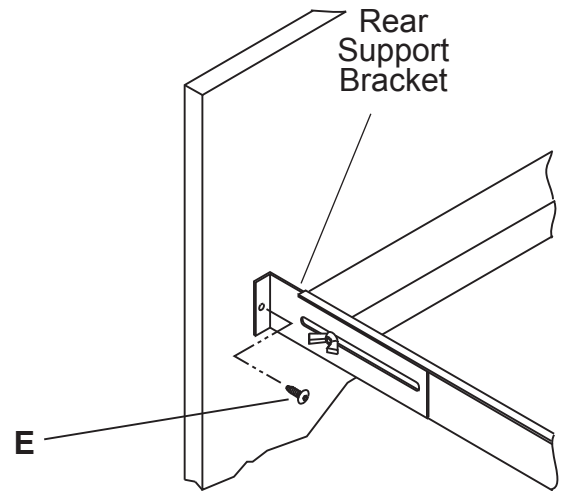

FIGURE A (Rear of Shelf)

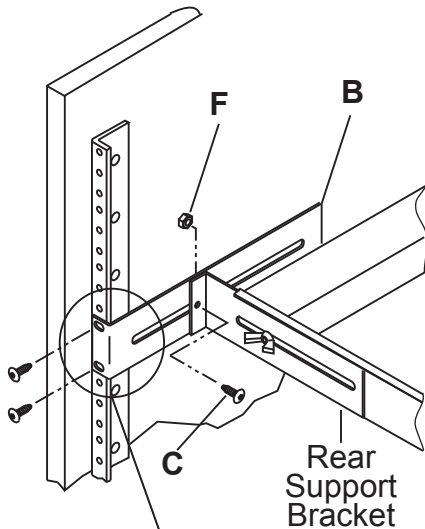
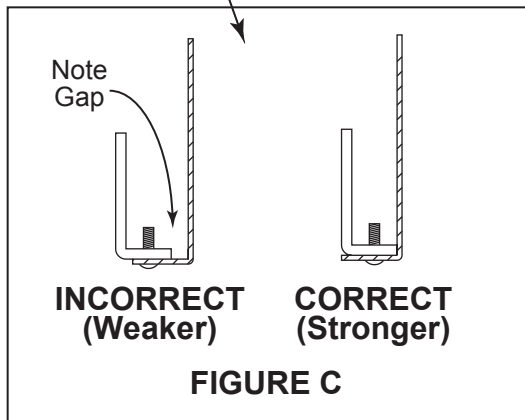

FIGURE B (Rear of Shelf)



INSTALLATION WITH REAR RAIL

- Attach PSSRB1s to the shelf's preinstalled rear support bracket with provided hardware. **(FIGURE B)**
- Ensure all brackets are aligned, tighten screws, nuts and preinstalled wing-nuts. **(FIGURE B)**

NOTE: Leave no gap during installation of part B. **(FIGURE C)**

HOOK AND LOOP FASTENER INSTALLATION

- Place soft material dot on the component's foot. If there is no feet on the component, place as close to the corner as possible to ensure stability. **(FIGURE D)**
- Mate coarse material dot on the soft material dot. **(FIGURE E)**

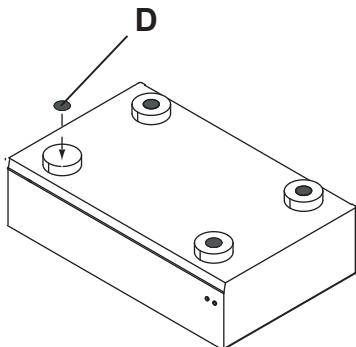

FIGURE D

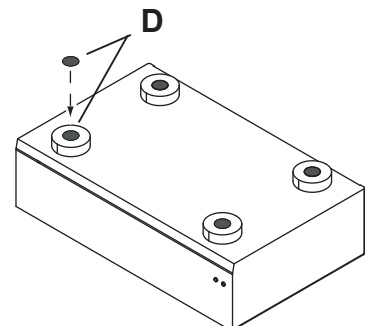

FIGURE E

HOOK AND LOOP FASTENER INSTALLATION CONTINUED

- Turn component over and place on predetermined location on the shelf. Gently press down on the component to adhere. **(FIGURE F)**

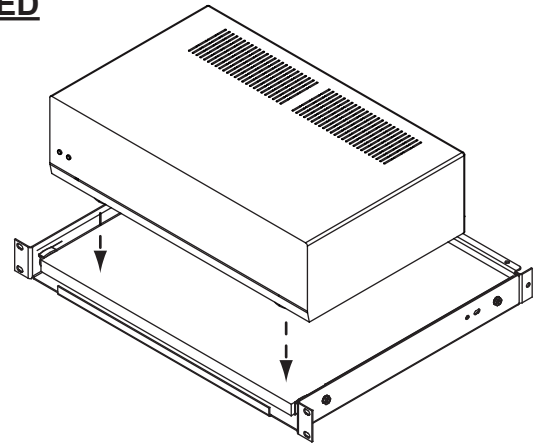
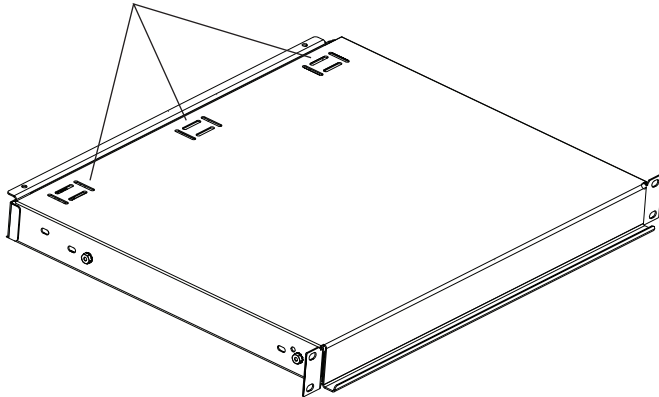

FIGURE F

LACING POINTS



SS FEATURE

- Cable lacing tie-points are across the back of the shelf.

WARRANTY

Middle Atlantic Products, Inc. (the "Company") warrants the SS/SSL to be free from defects in material or workmanship under normal use and conditions for a period of (3) three years from date of shipment by the company.

The Company's entire liability to the purchaser, and the purchaser's (or any other party's) sole and exclusive remedy, under this warranty shall be limited, at the Company's option, to either (a) return of and refund of the price paid for, or (b) repair or replacement at the Company's factory of the products purchased, or any part or parts thereof, which the Company has determined to be defective after inspection thereof at the Company's factory.

This warranty does not cover damage due to acts of God, accident, misuse, abuse or negligence by parties other than the Company, or any modification or alteration of the products. In addition, this warranty does not cover damage due to improper handling, assembly, installation or maintenance.

THIS WARRANTY IS IN LIEU OF ALL OTHER WARRANTIES OF ANY KIND, EITHER EXPRESSED OR IMPLIED, INCLUDING, BUT NOT LIMITED TO, IMPLIED WARRANTIES OF MERCHANTABILITY AND FITNESS FOR A PARTICULAR PURPOSE.

TO THE MAXIMUM EXTENT PERMITTED BY APPLICABLE LAW, IN NO EVENT SHALL THE COMPANY BE LIABLE FOR ANY SPECIAL, INCIDENTAL, INDIRECT, OR CONSEQUENTIAL DAMAGES WHATSOEVER (INCLUDING, WITHOUT LIMITATION, DAMAGES FOR LOSS OF BUSINESS PROFITS, BUSINESS INTERRUPTION OR ANY OTHER PECUNIARY LOSS) ARISING OUT OF THE USE OF THE PRODUCTS PURCHASED, EVEN IF THE COMPANY HAS BEEN ADVISED OF THE POSSIBILITY OF SUCH DAMAGES. THE COMPANY'S LIABILITY TO THE PURCHASER (OR ANY OTHER PARTY) HEREUNDER, IF ANY, SHALL IN NO EVENT EXCEED THE PURCHASE PRICE OF THE PRODUCTS PAID TO THE COMPANY.

Corporate Headquarters

Corporate Voice 973-839-1011 - Fax 973-839-1976 / International Voice +1 973-839-8821 - Fax +1 973-839-4982
middleatlantic.com - info@middleatlantic.com

Middle Atlantic Canada

Voice 613-836-2501 - Fax 613-836-2690 / middleatlantic.ca - customerservicecanada@middleatlantic.ca

Factory Distribution

USA: NJ - CA - IL Canada: ON - BC

At Middle Atlantic Products we are always listening. Your comments are welcome.