

TECHNICAL DATA SHEET - Flat Panel Accessory for VCR/DVD Mount



MODELS: ACC931, ACC931-S

Dimensions:

Weight:

7.24 lb (3.2 kg)

Shipping weight:

9 lb (4.1 kg)

Maximum Load Capacity:

30 lb (13.7 kg)

Shipping Carton dimensions:

L= 20.25 in. (514 mm)

W= 12.25 in. (311 mm)

H= 4.125 in. (105 mm)

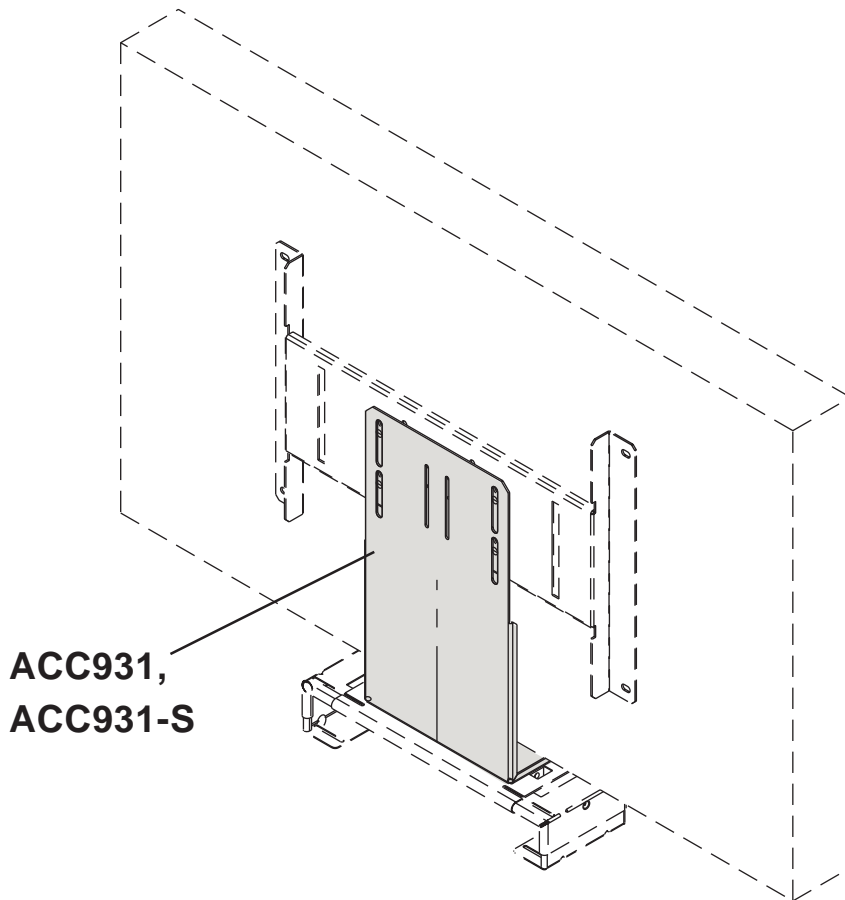

**ACC931,
ACC931-S**

ARCHITECTS SPECIFICATIONS

The monitor mount shall be a Peerless model _____ and shall be mounted where indicated on the plans. It shall be constructed of heavy gauge cold rolled steel, and finished with scratch resistant Black or Silver Fused Epoxy. Assembly and installation shall be done according to instructions provided by the manufacturer.

TECHNICAL DATA SHEET

MODELS: ACC931, ACC931-S

ALL DIMENSION = INCH
(MM)

RANGE	MIN.	MAX.
A	13.38 (340)	15.75 (400)

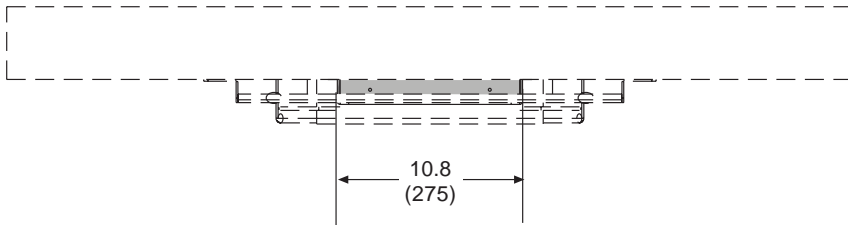

**TOP
VIEW**

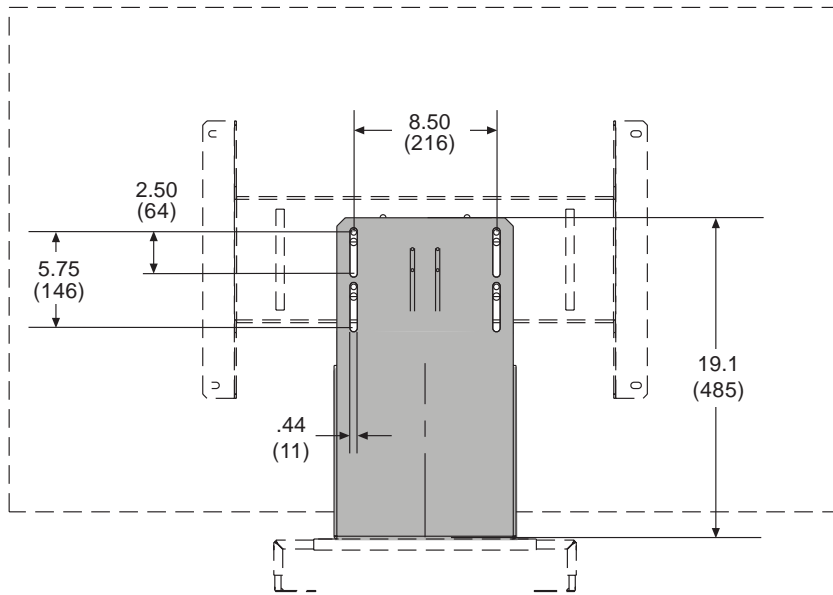

**BACK
VIEW**

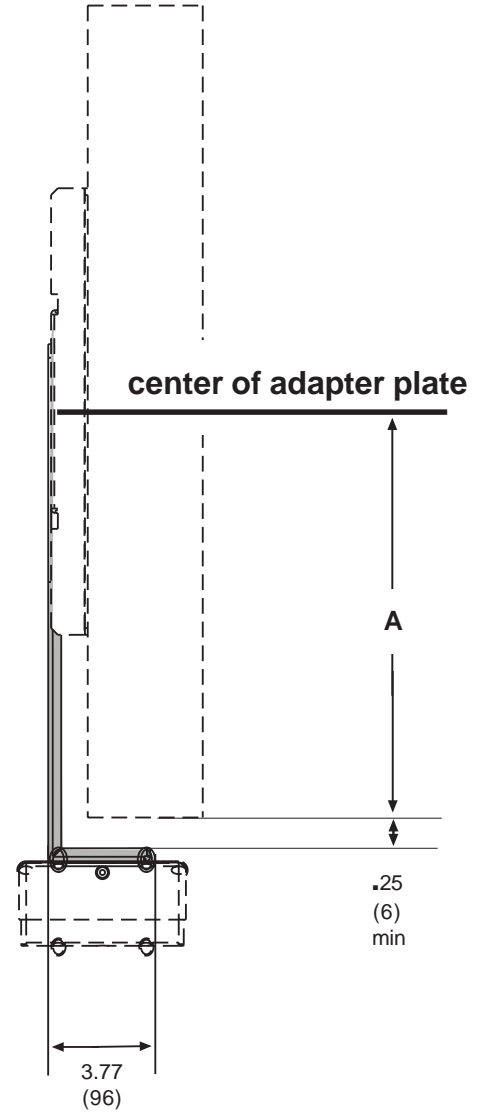

**SIDE
VIEW**