

**PART NUMBER SEQUENCE**

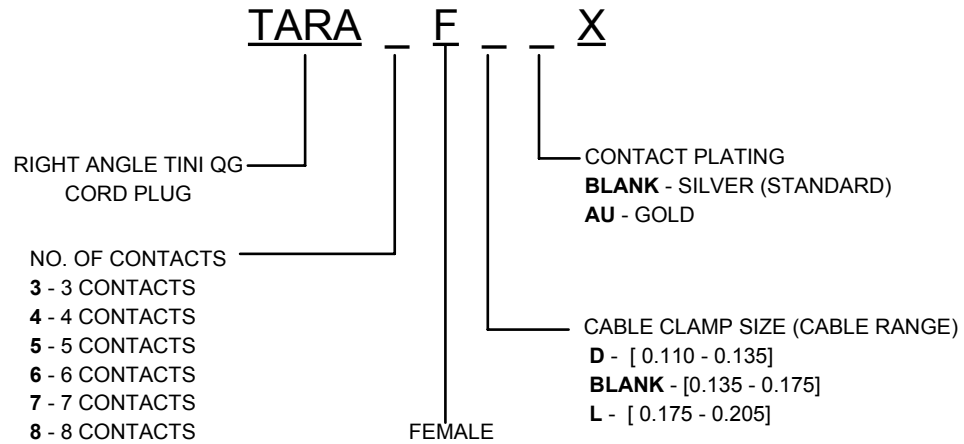

**INSTRUCTIONS:**

- CUT THE WIRES ACCORDINGLY AS SHOWN ABOVE.
- RUN IT THROUGH INSULATOR AND SOLDER THE CONTACT WIRES TO THE PLUG ASSEMBLY. CONNECT THE INSULATOR TO THE PLUG ASSEMBLY. THE CONTACTS IN THE PLUG ASSEMBLY CAN WITHSTAND 2.0 LBS PULL OUT FORCE.
- NOW SLIDE THE CONNECTED PLUG ASSEMBLY, INSULATOR INTO THE TINI QG HOUSING. MAKE SURE THAT THE PLUG ASSEMBLY IS BUTTED UP AGAINST THE FRONT OF THE TINI QG HOUSING.
- SOLDER THE GROUND TERMINAL WIRE TO THE TINI QG HOUSING'S LOWER THRU HOLE AS SHOWN.
- SLIDE THE BOTTOM PLASTIC HOUSING UP TOWARDS THE FEMALE HOUSING. THIS HOUSING CAN BE INSTALLED 90° ORIENTATED OTHER WAY IF PREFERRED.
- DROP AND SLIDE THE TOP RIGHT ANGLE HOUSING INTO THE GROVE SUCH AS IT LATCHES WITH THE BOTTOM PLASTIC AND FEMALE HOUSING.
- SLIDE THE CABLE CLAMP THROUGH THE CABLE INTO THE TOP/BOT HOUSINGS AS SHOWN.
- SCREW THE PLUG HANDLE TO 3 IN-LB MAX AND POP IN THE BOOT TO ASSEMBLE FULL PRODUCT.



REV	ECO NUMBER	DATE	BY	APVD
0D	ADDED DIMENSIONS LAYOUT CHANGED	09/18/18	AM	*
0C	ADDED PART NUMBERING SEQUENCE	09/25/17	AM	*
0B	EDITED LAYOUT	01/03/17	AM	*

☆ STAR SYMBOL DENOTES CRITICAL DIMENSION

**UNLESS OTHERWISE SPECIFIED**

- ALL DIMENSIONS IN INCHES  
- TWO PLACE DECIMALS ±0.01  
- THREE PLACE DECIMALS ±0.005  
- ANGLES ±1°  
- ALL DIA. CONCENTRIC WITHIN 0.005 T.I.R.
- FEATURES ON THE SAME CENTERLINE MUST BE ALIGNED WITHIN ±0.002
- REMOVE ALL BURRS

**DO NOT SCALE DRAWING**

THIS DRAWING DESCRIBES A DESIGN CONSIDERED PROPRIETARY IN NATURE, DEVELOPED AND MANUFACTURED BY SWITCHCRAFT INC. AND IS RELEASED ON A CONFIDENTIAL BASIS FOR IDENTIFICATION PURPOSES ONLY.									
SIZE *	WIDTH *	MULT *	LBS/M *	TEMPER *					
FINISH *				MATERIAL *					
SPEC No. *				SPEC No. *					
FIRST USED ON *		SCALE 1:1			<b>Switchcraft®</b>				
DATE DRAWN	BY	CHKD	APVD						
07/27/16	AM	*	*	SHEET 1 OF 1					
NAME				PART No.	REV				
TINI QG, FEMALE RA RoHS				TARA_FX SERIES_CD	0D				

**CUSTOMER DRAWING**